

# **Presto** LIFTS **ECO A**

PLS67-175 Battery  
powered lift  
Instructions



Presto Lifts Inc.  
50 Commerce Way, Norton MA 02766  
1-800-343-9322  
Fax: 1-888-788-6496

Version 01

# Contents

1. Specifications .....	3
2. General safety precautions during use .....	3
2.1. Safety systems .....	3
3. Application .....	3
4. Operating the Lifter .....	4
4.1. The remote control symbols .....	4
5. Batteries and charger .....	5
6. Design .....	5
7. Residual risks .....	5
8. Resolving faults .....	6
9. Lifting equipment .....	7
9.1. Forks and platforms .....	7
9.2. Boom and Crane arm .....	7
9.3. V-block and WAVE .....	7
9.4. Boom with V-block .....	7
9.5. The gripping device QC - EG .....	8
9.6. Turning device .....	9
9.7. Tipping Device .....	10
9.8. Tube .....	10
9.9. Reel Handler .....	11
10. Wiring Chart .....	12
12. Load diagram .....	13

## 1. Specifications

		Low	Medium	High
Weight (kg)	PLS67-175	30	31	
Max. load (kg)	PLS67-175	80		
Protection class		IP41		
Batteries Type VRLA		24V, 9.0 Ah or 24V,18AH		
		(maintenance free)		
Charger		230V – 2 A or 230V – 3A		
Charging time		4-5 hours (80%) 8 hours (100%)		
Sound pressure level	≤ 70 Db(A)			
Vibration strength	≤ 2.5 m/s <sup>2</sup>			

For additional technical specifications and dimensions please contact the vendor.

## 2. General safety precautions during use

No forklift license or other training is required to lawfully operate a lifter.

The following guidelines must be followed when using a Lift:



- o Under no circumstances should the lift elevate more than specified:  
PLS67-175            80 kilo 400 mm from the mast
  
- o Under no circumstances should the lift elevate more than specified.
- o The lift must not be used for lifting persons or live animals.
- o Only one person must operate the lift at the time.
- o No body parts near the sledge or tool at the mast or other lifting equipment when operated up or down.
- o Secure that there are no one below the load, tool and lift when operated.
- o Only use the lift when operated on a hard leveled surface during lifting or transporting loads.
- o When moving a load the load should be lowered to the lowest possible position and secured in order ensure that the load cannot slide.
- o Always secure the load on the lift when moving.
- o When leaving or storing the lift, always ensure that the sledge is lowered to the lowest possible position and that the lift is free of any load or cargo.
- o The load's center of gravity should always be behind the front wheels of the legs.
- o The lift should only be cleaned by wiping it with a damp cloth. Water may create damage to the electrical components or PCB.
- o According to the Danish Working Environment Service, the lift must be inspected at least once a year by the manufacturer or a skilled technician.

### 2.1. Safety systems



The lift is equipped with the following safety systems:

- o One-way ball bearings on drive shaft that eliminate the risk of crushing when lowering.
- o Overload sensor that disconnects the lifting function if the load is greater than the lift's capacity or if the load is unevenly placed (this does not prevent overloading when the lifter is not lifting).
- o The charger is protected with a fuse.

## 3. Application

The lift and platform may only be used for lifting and handling goods.

#### 4. Operating the Lifter

Some models are operated using the switch located on the lift's control panel on the mast:

The lifter will lift while the button is pressed  
 The lifter will lower while the button is pressed

If the lift is delivered with lifting equipment, specific operating instructions are required.

Some models with electric tools are operated using a remote control with a spiral cord. The remote control may be equipped with a variable number of buttons depending on what equipment the lift is delivered with.

Button 1 and 2 are used for lifting and lowering functions.  
 Button 3 to 8 are used for operating the electric tools like gripping, turning and tipping.

The remote control of a standard lift has 2 buttons with arrows (buttons 1 and 2), which operate as follows:

The lift will lift while the button is pressed  
 The lift will lower while the button is pressed

If the lift is equipped with 2 speeds (normal and reduced) the remote control has 4 buttons (buttons 1 to 4): Buttons 1 and 2 activate the lifting and lowering functions at normal speed. Button 3 and 4 activate the lifting and lowering functions at decreased speed.

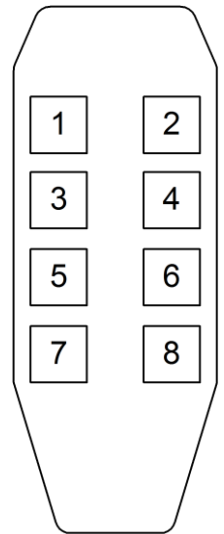

#### 4.1. The remote control symbols

If the lift is equipped with standard equipment the symbols in the table below is used on the remote control:

Button no. / Function	Symbol	Comments
1 Lifting		
2 Lowering		
(3) Reduced Speed lifting		optional by simple tool
(4) Reduced Speed lowering		optional by simple tool
3 Turning right (clockwise)		
4 Turning left (counter clockwise)		
3 Tipping forward / down		
4 Tipping backwards / up		
5+6 Gripping		2 buttons must be pressed at the same time
7+8 Opening		2 buttons must be pressed at the same time
5+6 Manipulator expanding		2 buttons must be pressed at the same time
7+8 Manipulator closing		2 buttons must be pressed at the same time

## 5. Batteries and charger

### Battery indicator

The lift is equipped with a battery status indicator that indicates the battery status when the lift button is activated.

Red indicator: Batteries must be recharged immediately.

Green indicator: The batteries are functionally charged.

The lift is charged with a built-in 230V charger. The charger should be connected daily due to that complete discharge can damage the batteries or shorten their lifespan.

### Charger indicator

Lifts with 2A charger (peep hole at the bottom of the control box).

Red indicator: the charger is connected to main power and charging.

Green indicator: the batteries are functionally charged. The indicator changes to green after 1 to 5 hours, which corresponds to 80% charge. A full charge takes approximately 8 hours. The charger automatically charges the batteries and switches to maintenance charging when the batteries are fully charged.

Lifts with 3A charger (indicator at the top of the control box).

☒ The yellow LED indicates the charger is connected to main power.

☒ Green charging indicator: the batteries are functionally charged. The indicator changes to green after 1 to 5 hours, which corresponds to 80% charge. A full charge takes approximately 8 hours. The charger automatically charges the batteries and switches to maintenance charging when the batteries are fully charged.

## 6. Design

The mast is of aluminum profile (AlMg3)

The sledge, handlebar and base frame are made of powder-coated or electro-galvanized steel.

## 7. Residual risks

There are residual risks for extraordinary wear, material or product failure due to great impact from collision, misuse, obstacle interference, blockade of driveways, etc; e.g. a faulty wheel bearing as a result of a heavy collision.

8. Resolving faults

Fault type	Check the following	Solve
The timing belt jumps on the belt wheel (the belt is making crackling noises)	Is the belt slack?	Tighten the belt using the two screws at the top of the mast.
	Is the belt worn?	Replace the belt
The belt is skewed (the belt squeaks)	Is the belt running skewed in the track on the top cog wheel?	Adjust the screw at the top of the mast, on the side to which the belt is skewed.
	Is the belt worn?	Replace the belt
The sledge jerks	Is there dirt in the mast on which the sledge runs?	Remove the dirt and wipe with alcohol.
	Is there dirt on the sledge wheels?	Remove the dirt or replace the wheels.
The lift does not respond	Check whether the ON/OFF button is activated	Release the ON/OFF button
	Check whether the item being lifted is heavier than the lift's capacity	Remove the item
	Check the main fuse	Replace the main fuse
	Check that the batteries are charged	Connect the charger
The lift works very slowly	Check the voltage of the batteries	Connect the charger
	Check the charging frequency. Does the light quickly change turn green when connected?	If the charger quickly changes to green, indicates that the batteries should be replaced.

## 9. Lifting equipment

The sledge on the lift are equipped with holes for mounting accessories and tools, as described below.

### 9.1. Forks and platforms

#### Application

The forks (G) can be in painted steel or stainless steel. Platforms can be in PEHD (KP) or stainless steel (EP).

Forks and platforms can be used to handle various items like boxes or sacks.



#### Safety when using forks or platforms

Items handled with the platform must not be substantially larger than the platform due to potential risk. Likewise, boxes or pallets handled with forks must fit the forks.

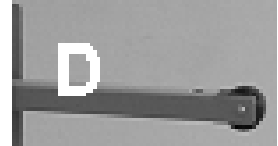

### 9.2. Boom and Crane arm

#### Application

The boom is used for handling reels or round items. The lift can be equipped with different types of booms:

- o Single booms (D) are used for lifting reels at the center tube.
- o Double booms (DD) are used for lifting reels from beneath without the center tube being "blocked".
- o A boom can be fitted with easy-running ball bearings (DR) to facilitate the removal and fitting of very heavy reels.
- o Crane arm (KA) is a boom with an adjustable hook.

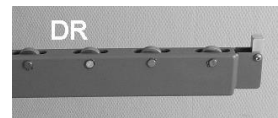

#### Safety when using boom or crane arm

Lifting must not begin before the reel is fully mounted and secured on the boom.

The boom length should be at least 2/3 of the reel's length.

Booms with easy-running ball bearings (DR) are equipped with a safety latch to ensure that items do not unintentionally slide off the boom during handling or transporting.

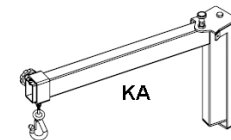

When moving the lift, the crane arm should be elevated as lowered as possible and must be handled with care in order to avoid the load from swinging. The hook should be as close to the mast as possible and secured so that it cannot slide on the crane arm while being moved.

### 9.3. V-block and WAVE

#### Application

The V-block is used for handling reels that is subsequently transferred to an axel or boom for a packaging machine or similar.

#### Operation

The V-block (EPV) is inserted into the central tube of the lift's standard platform. The V-block can be rotated to ensure the correct loading and unloading of the reel.

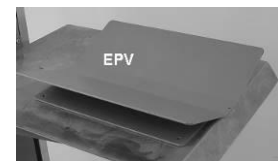

#### Safety when using the V-block

It is important that the item is placed in the middle of the V-block at the longitudinal direction, as the load may become unbalanced during the subsequent rotation of the item.

Reels handled with V-blocks should not be more than 500mm in diameter, due to the risk of losing the reel.

### 9.4. Boom with V-block

#### Application

Boom with V-block (DVB) is used for handling reels that are both lifted by their central tube and from beneath.



#### Operation

The boom is equipped with a wheel at the front to facilitate the loading of the reels. When the V-block is used it is placed into the center of the boom. The V-block can be rotated to ensure the correct loading and unloading of the reel.

#### Safety when using the V-block

It is important that the reel is placed in the middle of the V-block in a longitudinal direction in order to prevent uneven loading or the reel falling off.

Reels handled with V-blocks should not be more than 500mm in diameter; otherwise, there is a risk of dropping the reel.



9.5. The gripping device QC - EG

Application

The gripping device is used to handle items which, due to their shape, are difficult to handle. These may typically be containers, vessels or drums.

The gripping unit is used in combination with a turning or tipping device.

QC6 = Quick clamp with turning unit

EG6 = linear clamp with turning unit

EG8 = linear clamp with tipping unit

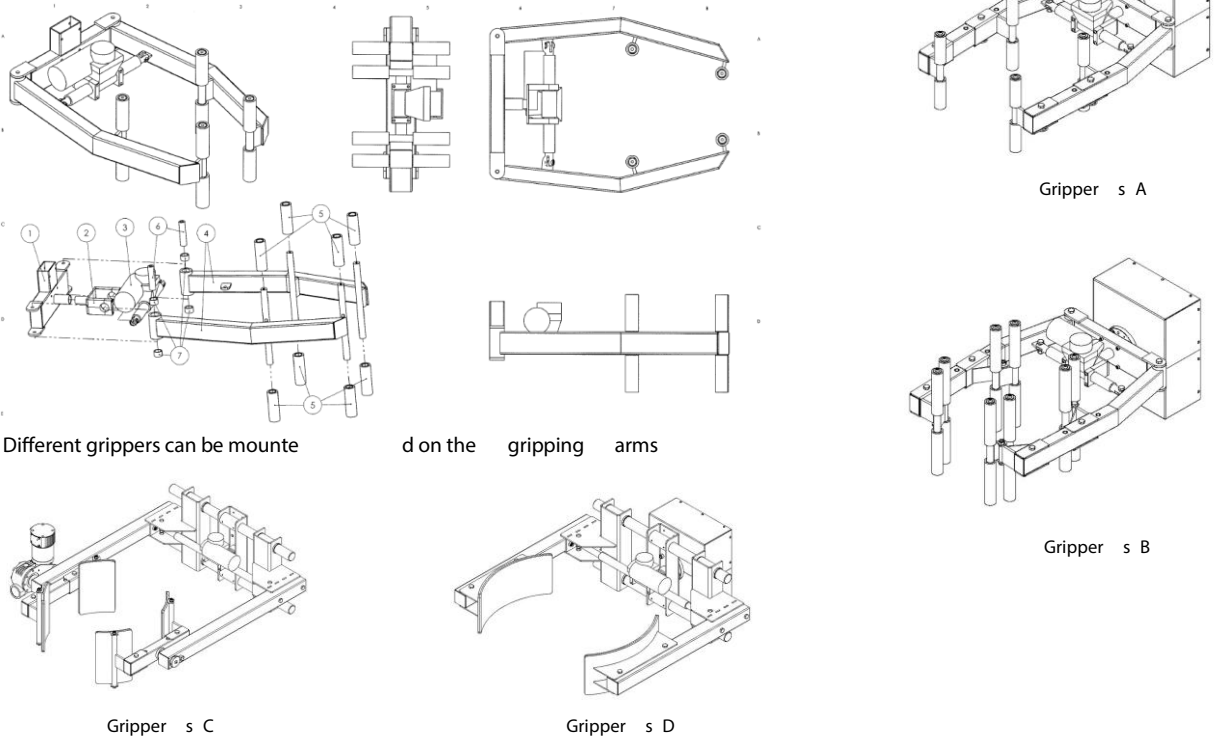

Different grippers can be mounted on the gripping arms

Operation

The gripping device is available with manual or electrical functionality.

Buttons 5, 6, 7 and 8 are used to operate the electrical gripper functions.

Buttons 5 and 6 activate the closing function; buttons 7 and 8 activate the release function.

When combined with a turning or tipping device, use buttons 3 and 4 for the turning/tipping function

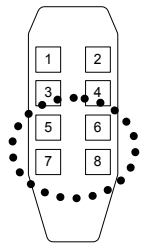

Safety when using the gripping device

Due to the risk of dropping the load through improper use of the remote control, the opening and closing functions are operated with two buttons; i.e. both buttons must be activated in order to perform the desired movement.

Caution : there is a risk of clamping if the safety instructions for using the lift are not followed (see section 1).



Adjusting reel manipulators

Extending the parameters should only be adjusted by skilled technicians, as improper procedures may lead to insufficient grip and/or irreversible motor damage.



The following parameters may be adjusted in the control box:

Current (Amps) : P3 is used to adjust the expander motor's power, for example, if the elevated item encounters a risk of being damaged by handling it with the reel manipulator. Similarly, problems holding items with smooth surfaces at their center may be resolved by increasing the power. If the speed of the expander is adjusted simultaneously, it is important that this is adjusted before the amps are adjusted.

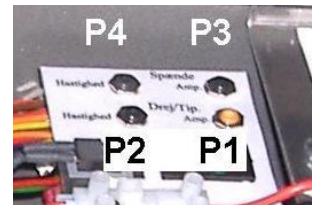

Expander speed: P4 is used to adjust the speed of the motor, and hence the speed at which the expander function opens and closes.



9.6. Turning device

Application

The turning device is used to rotate an item. It is often used in combination with a gripping device QC or EG.

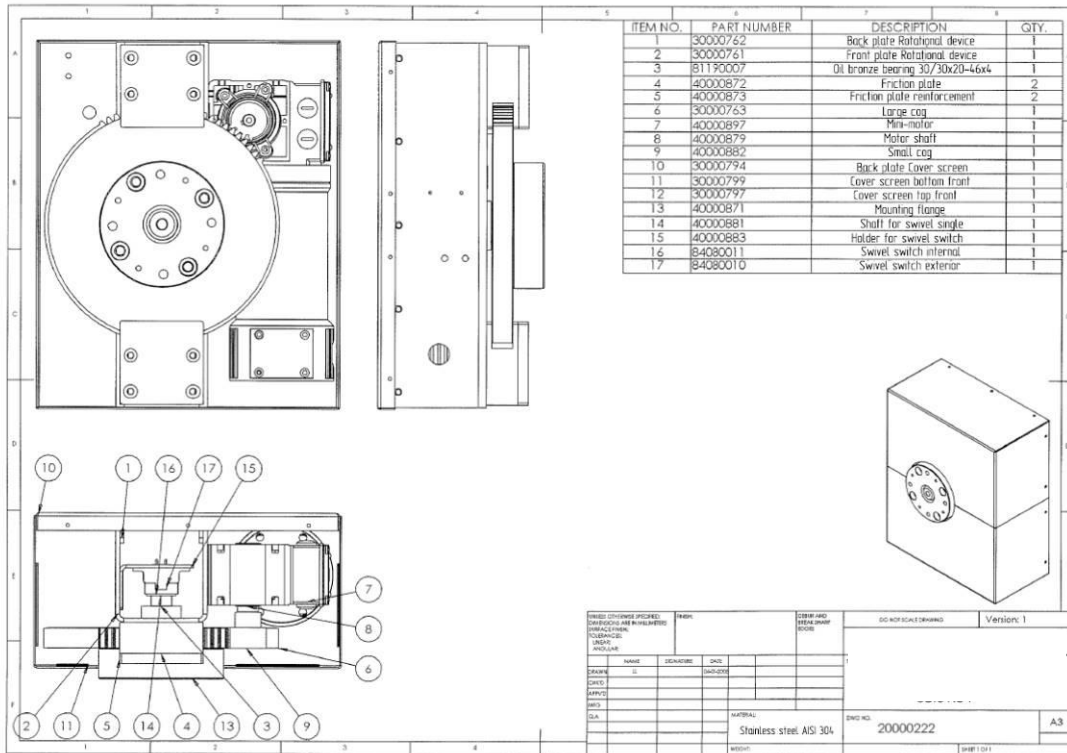

Operation

The turning device is available as an electrical rotational function. Optional with electronic stop at 0° and 180°

To operate the electrical turning function, button 3 and 4 on the remote control are used for left and right rotation respectively.

Safety when using the turning device

Before the turning function is activated, it is advisable to check that the item is properly secured in the clamping grippers in order not to drop the item during subsequent rotation. It is also important to ensure that the item is sufficiently lifted of the floor and away from other obstacles that may collide with the lifter's legs or surroundings during rotation.



Adjusting the PLC parameters

Expanding parameters should only be adjusted by skilled technicians, as improper procedures may lead to insufficient clamping power and/or irreversible motor damage.

The following parameters may be adjusted in the control box:

Amps: P1 is used to adjust the motor's power, and hence the pressure on the item. If the speed of the rotational device is adjusted simultaneously, it is important that this is adjusted before the amps are adjusted.

Speed: P2 is used to adjust the speed of the rotary motor, and hence the speed of the equipment's movement.

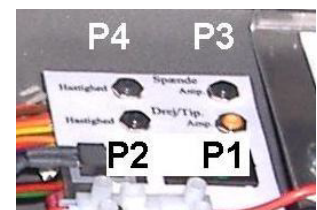
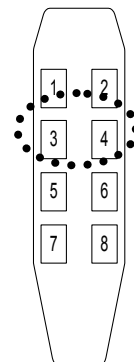

9.7. Tipping Device

Application

The tipping device is used to empty or tip items in a forward direction, typically for pouring liquids from containers or tanks.

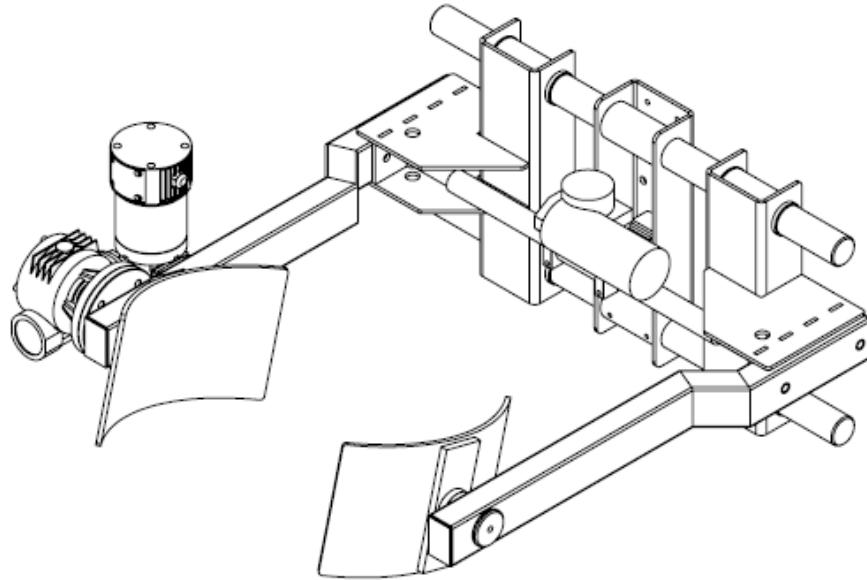

Operation

The tipping unit has an electrical tipping functionality. To operate the electrical tipping function, button 3 and 4 on the remote control are used for forward and reverse rotation respectively.

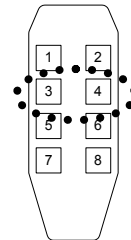

9.8. Tube

Application

Tube is used for handling reels of stretch film.

The mandrel is lowered into the reel. Make sure that the mandrel is placed on the reel.



Safety when using Tube

Do not allow personnel directly in front of Tube when reel are mounted.  
The lift must always be operated from behind.



Tube

## 9.9. Reel Handler

### Application

The Reel Handler is used to handle reels of stretch film.

The forks are leveled vertically to fit the top and bottom of the reel with stretch film. The reels can be taken directly from the pallet or from the floor.

The truck is pushed forward so that the fork gets hold of the reel. The reel can then be transported.

The reel can be turned using the handles. Use both handles for easy turning.

The reel can be deposited either up or down on the mandrel depending of the stretch film machine interface.

An optional extra transport security can be purchased. The cord is tightened around the reel when the lift must pass through rolling terrain with lift loaded. The transport lock is mounted with a screw.



### Safety when using the Reel Handler

Check that both forks are passed so far through the roll as possible before the roll is lifted.

When the reel is turned, the driver must be safely positioned behind the forks to avoid damage and injuries caused by the reel. Do not allow personnel immediately in front of the fork when scrolling in the fork

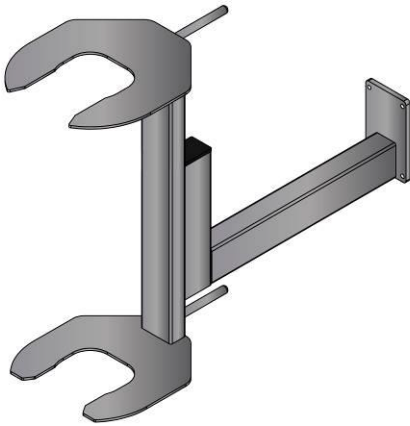

Reel Handler

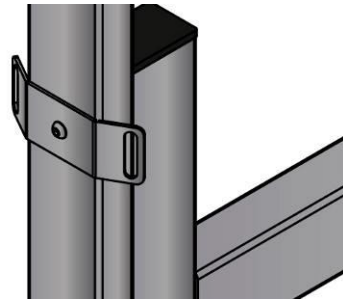

Extra equipment: Transport security

10. Wiring Chart PLS67-175

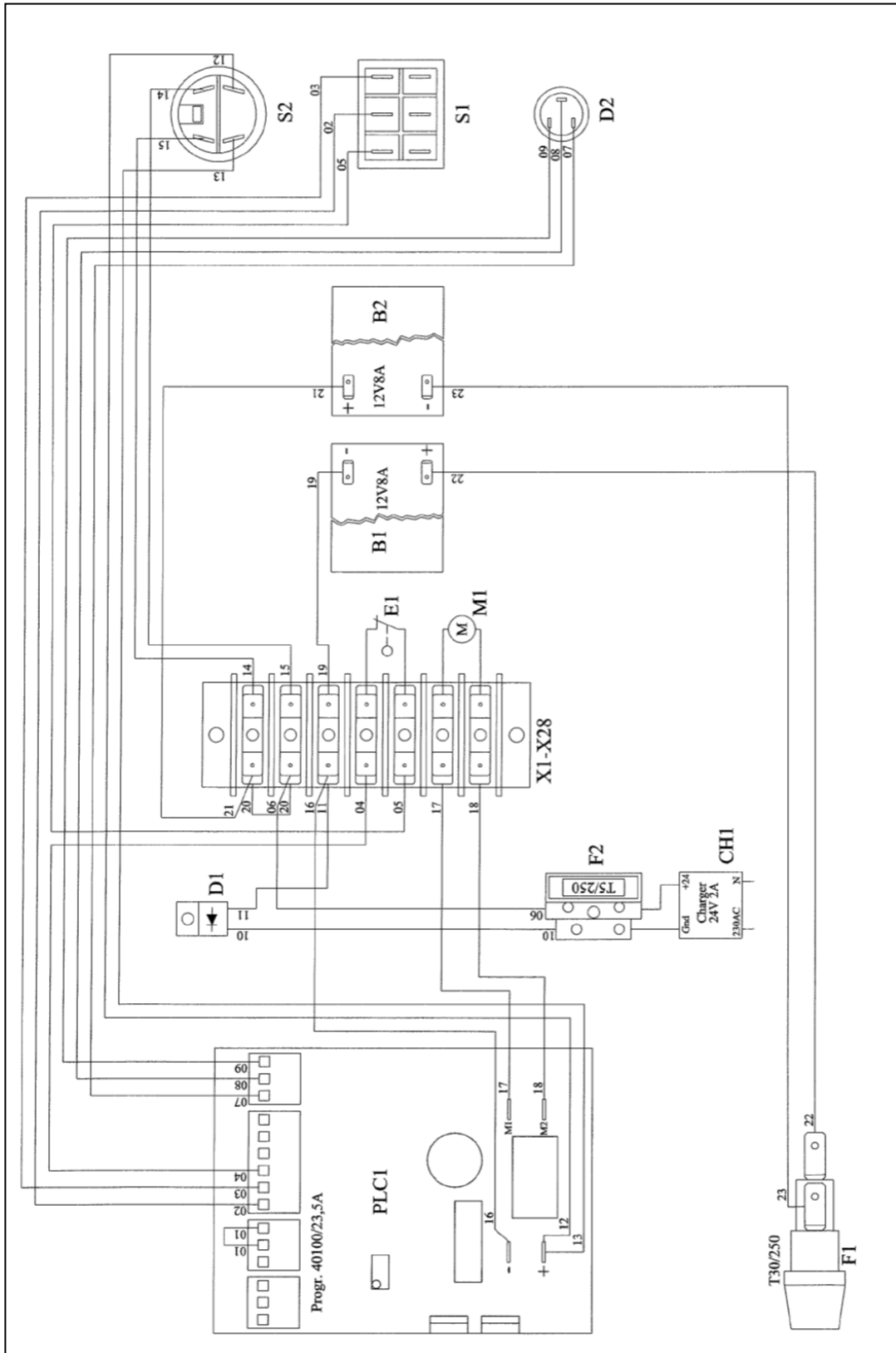

12. Load diagram

Max weight on lift with mass center x mm from mast

