



HELP LINE
If you are not
satisfied in any way
contact
Presto
Parts or Service
1-800-343-9322

Presto LIFTS™

worldwide material handling
and ergonomic solutions

M800 Series

Hand Operated Stackers



Parts List

Model Number _____

Serial # _____

Date placed in service _____

IMPORTANT: READ CAREFULLY
BEFORE INSTALLING OR OPERATING LIFT

Part orders are subject to a \$50 minimum charge

This manual was current at the time of printing. To obtain the latest, most updated version, please contact the Customer Service Department or go to our website: www.PrestoLifts.com -- you will find a complete list of current owner's manuals to print.

CONTENTS

SECTION 1:	
Introduction.....	4
Responsibility of Owners and Users.....	5
SECTION 2:	
Safety Alert Symbols and Signal Words.....	6
Safety	7
SECTION 3:	
Installation.....	7
SECTION 4:	
Operation.....	7
ORDERING REPLACEMENT PARTS	16
RESTOCKING POLICY & RGA POLICY	17
RETURN MATERIALS AUTHORIZATION (RMA) PROCEDURES	18
WARRANTY	19

LIST OF FIGURES:

Figure 1: Pump Diagram (Prior to May 2010).....	8
Figure 2: Pump Diagram (After May 2010)	9
Figure 3: Component Parts	10
Figure 4: Hydraulic Diagram	11
Figure 5: Backplate Assembly Diagram	12
Figure 6: Fork Weldment Diagram	13
Figure 7: Portability Package Diagram	14
Figure 8: Label Location	15

LIST OF TABLES:

Table 1: Hydraulic Oil Specifications	16
---	----

SECTION 1

INTRODUCTION

This manual attempts to provide all of the information necessary for the safe and proper installation, operation and maintenance of Presto Lifts Inc.'s MSeries Stackers. It is important that all personnel involved with the installation, maintenance or operation of the stacker read this manual. Where unique situations arise, that are not covered in this manual call Presto Lifts for further instructions. Additional manuals are available upon request or on our web site at www.prestolifts.com.

The stacker has a nameplate that provides the load capacity ratings, serial number and model identifications. Please refer to these numbers when ordering parts or requesting further information.

WHERE UNIQUE SITUATIONS ARISE, THAT ARE NOT COVERED IN THIS MANUAL, CALL PRESTO LIFTS SERVICE DEPARTMENT FOR FURTHER INSTRUCTIONS.

Responsibility of Owners and Users

Inspection and Maintenance

The device shall be inspected and maintained in proper working order in accordance with Presto's owner's manual.

Removal from Service

Any device not in safe operating condition such as, but not limited to, excessive leakage, missing rollers, pins, or fasteners, any bent or cracked structural members, cut or frayed electric, hydraulic, or pneumatic lines, damaged or malfunctioning controls or safety devices, etc. shall be removed from service until it is repaired to the original manufacturer's standards.

Repairs

All repairs shall be made by qualified personnel in conformance with Presto's instructions.

Operators

Only trained personnel and authorized personnel shall be permitted to operate PowerStak.

Before Operation

Before using the device, the operator shall have:

- Read and/or had explained, and understood, the manufacturer's operating instructions and safety rules.
- Inspected the device for proper operation and condition. Any suspect item shall be carefully examined and a determination made by a qualified person as to whether it constitutes a hazard. All items not in conformance with Presto's specification shall be corrected before further use of the PowerStak.

During Operation

The device shall only be used in accordance with this owner's manual.

- Do not overload.
- Ensure that all safety devices are operational and in place.

Modifications or Alterations

Modifications or alterations to any Presto industrial positioning equipment shall be made only with written permission from Presto.

SAFETY ALERT SYMBOLS AND SIGNAL WORDS

The safety of all persons operating, maintaining, repairing, or in the vicinity of this equipment is of paramount concern. This is a powerful machine with moving parts, and is capable of causing personal injury if proper precautions are not taken. Therefore, throughout this manual, certain hazards have been identified which may occur in the use of the machine, and there are appropriate instructions or precautions which should be taken to avoid these hazards. In some cases, there are consequences which may occur if instructions or precautions are not followed. Below are the symbols and signal words along with their definitions referenced from ANSI Z535.4 - Product Safety Signs and Labels.

Safety Alert Symbols

These are the safety alert symbols.. They are used to alert you to potential physical injury hazards. Obey all safety messages that follow this symbol to avoid possible injury or death.



For use with DANGER signal word
(Red Background)



For use with WARNING signal word
(Orange Background)



For use with CAUTION signal word
(Yellow Background)

Signal Words

The meaning of different signal words as defined by ANSI Standard Z535.4 indicates the relative seriousness of the hazardous situation.



(Red Background)

DANGER indicates a hazardous situation which, if not avoided, will result in death or serious injury.



(Orange Background)

WARNING indicates a hazardous situation which, if not avoided, could result in death or serious injury.



(Yellow Background)

CAUTION, used with the safety alert symbol, indicates a hazardous situation which, if not avoided, could result in minor or moderate injury.



(Blue Background)

NOTICE is used to address practices not related to personal injury.



(Green Background)

SAFETY INSTRUCTIONS (or equivalent) signs indicate safety-related instructions or procedures.

SECTION 2 **SAFETY**

The M Series stackers are very capable of causing serious injury or damage if adequate precautions are not taken. By reading and following this manual, operator injury may be prevented.

DO NOT INSTALL OR OPERATE THESE LIFTS WITHOUT CAREFULLY READING THIS MANUAL. In order to provide for the safe operation of these stackers, Presto Lifts Inc. has identified certain hazards that may occur during the installation, maintenance and use of these lifts.

▲WARNING

- Do not perform any repair work on lifts if there is a load on the platform or forks are in the raised or lowered position.
- All personnel must stand clear of the lift when the lift is in motion.
- Do not put hands or feet under forks or platform while in motion.
- Do not put hands or feet on or near the mast while the forks or platform is in motion.
- Do not stand, sit or climb on the lift.
- Do not exceed the load capacity.
- Place all loads centrally located on the lift forks or platform.
- Do not place a load on a moving lift.
- Do not use the lift on soft, uneven or unstable surfaces.
- Do not shock load the forks or platform. Materials must be carefully placed rather than dropped.

SECTION 3 **INSTALLATION**

INSTALLATION

When the stacker arrives on a pallet the following steps are to be followed:

1. Through the use of a forklift or overhead hoist, pick the stacker unit up taking into consideration the center of gravity. The center of gravity of the unit should be adequately supported.
2. Once the unit is lifted from the pallet by a couple of inches, remove the pallet from under the stacker.
3. Follow the next sections to ensure proper operation.

SECTION 4 **OPERATION**

METHOD OF OPERATION:

In order to operate the lift follow these operating procedures.

- 1). To raise the platform or forks, rotate hand control until platform reaches desired height.
- 2). To lower lift, press release pedal down. Pressure on release pedal controls speed of descent of load.

FIGURE 1: PUMP DIAGRAM

Note: View shown is for machines manufactured prior to May 2010.

Contact the Parts Department with model & serial number of machine as well as what parts are needed. Individual components will be sold as part of repair kits.

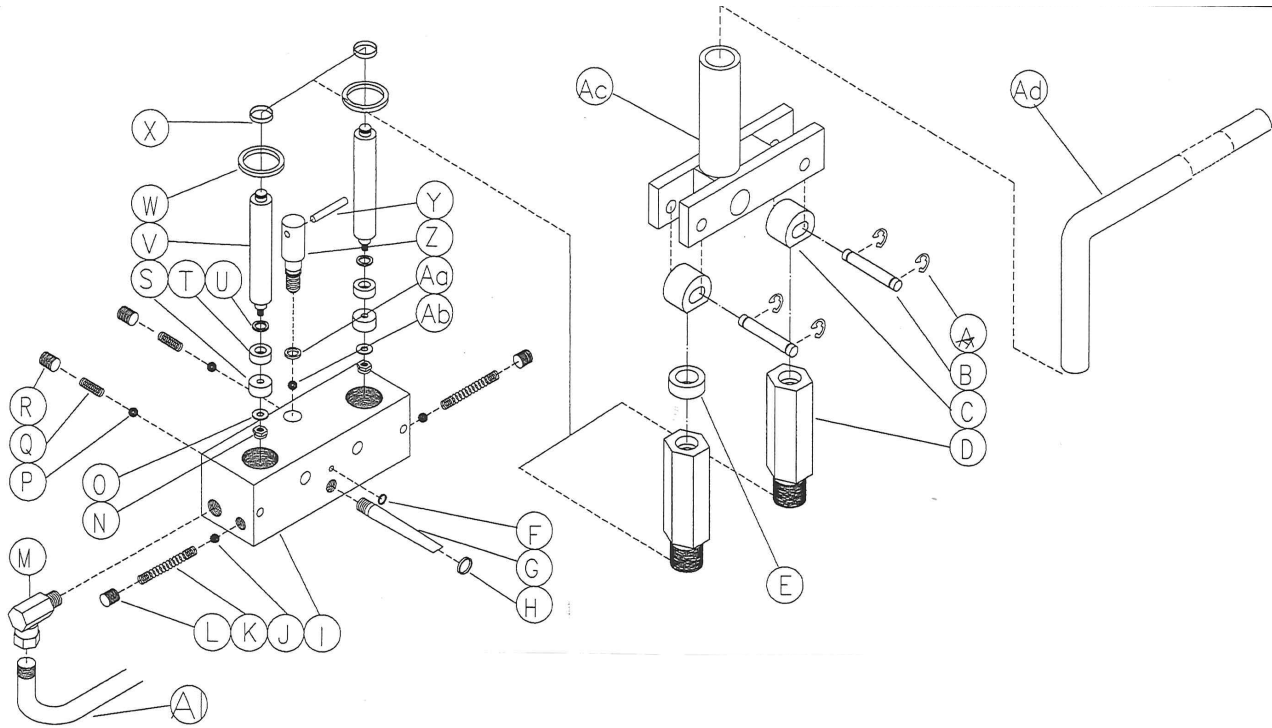

Item	Print	P/N	Item	Print	P/N
A	44	PSL28A	R	34	N1200
B	45	M423	S	37	M448
C	46	M404-3	T	38	M407A
D	132	L550	U	39	M407B
E	135	R733	V	131	R713
F	39	M407B	W	41	M443
G	90	R730	X	43	M445
H	127	R709	Y	134	R720-1
I	128	R707A	Z	133	R720
J	29	M439	Aa	39	R721
K	125	R725	Ab	29	M439
L	34	N1200	Ac	136	*R703
M	91	R723	Ad	137	R702
N	35	M446	A1	145	H116
O	36	M447			
P	29	M439			
Q	130	R728			

FIGURE 2: PUMP DIAGRAM

Note: View shown is for machines manufactured **after** May 2010.

Contact the Parts Department with model & serial number of machine as well as what parts are needed.
Individual components will be sold as part of repair kits.

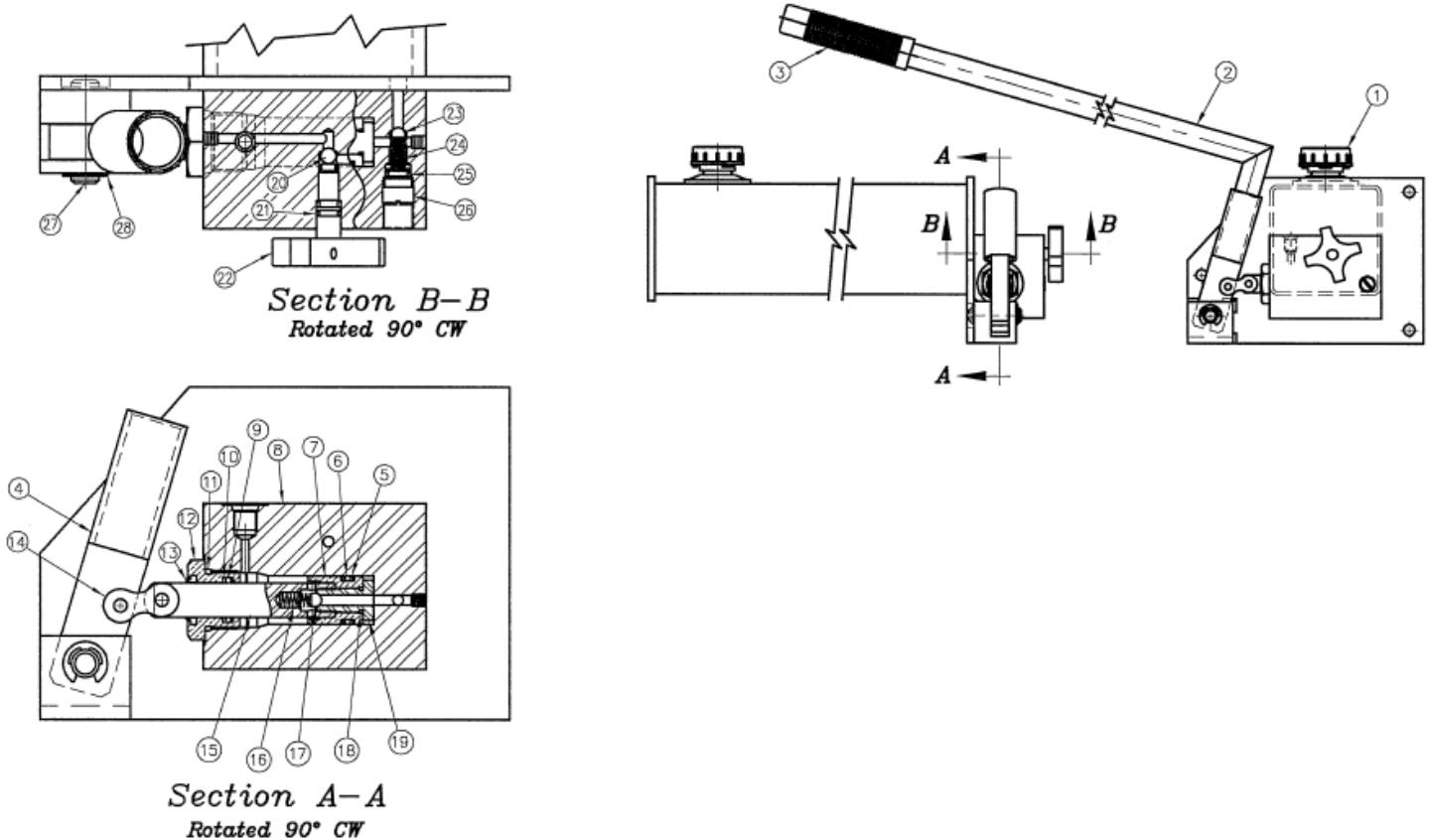

Item	Description	Qty
1	Reservoir Breather	1
2	Pump Lever	1
3	Pump Lever Grip	1
4	Lever Socket	1
5	Piston Seal Backup	2
6	Piston Seal	1
7	Piston	1
8	Pump Body Ass'y	1
9	Rod Seal	1
10	Rod Seal Backup	1
11	Gland Seal	1
12	Gland	1
13	Rod Wiper	1
14	Lever Link Ass'y	1

Item	Description	Qty
15	Piston Rod	1
16	Pressure Spring	1
17	Pressure Ball	1
18	Pist. Retainer Seal	1
19	Piston Retainer	1
20	Release Ball	1
21	Release Screw Seal	1
22	Release Screw Ass'y	1
23	Suction Ball	1
24	Suction Spring	1
25	Suction Valve Seal	1
26	Suction Valve Screw	1
27	Pivot Pin	1
28	Retaining Ring	2

FIGURE 3: COMPONENT PARTS

Contact Parts Department with the model and serial number of your machine to determine what parts are needed.

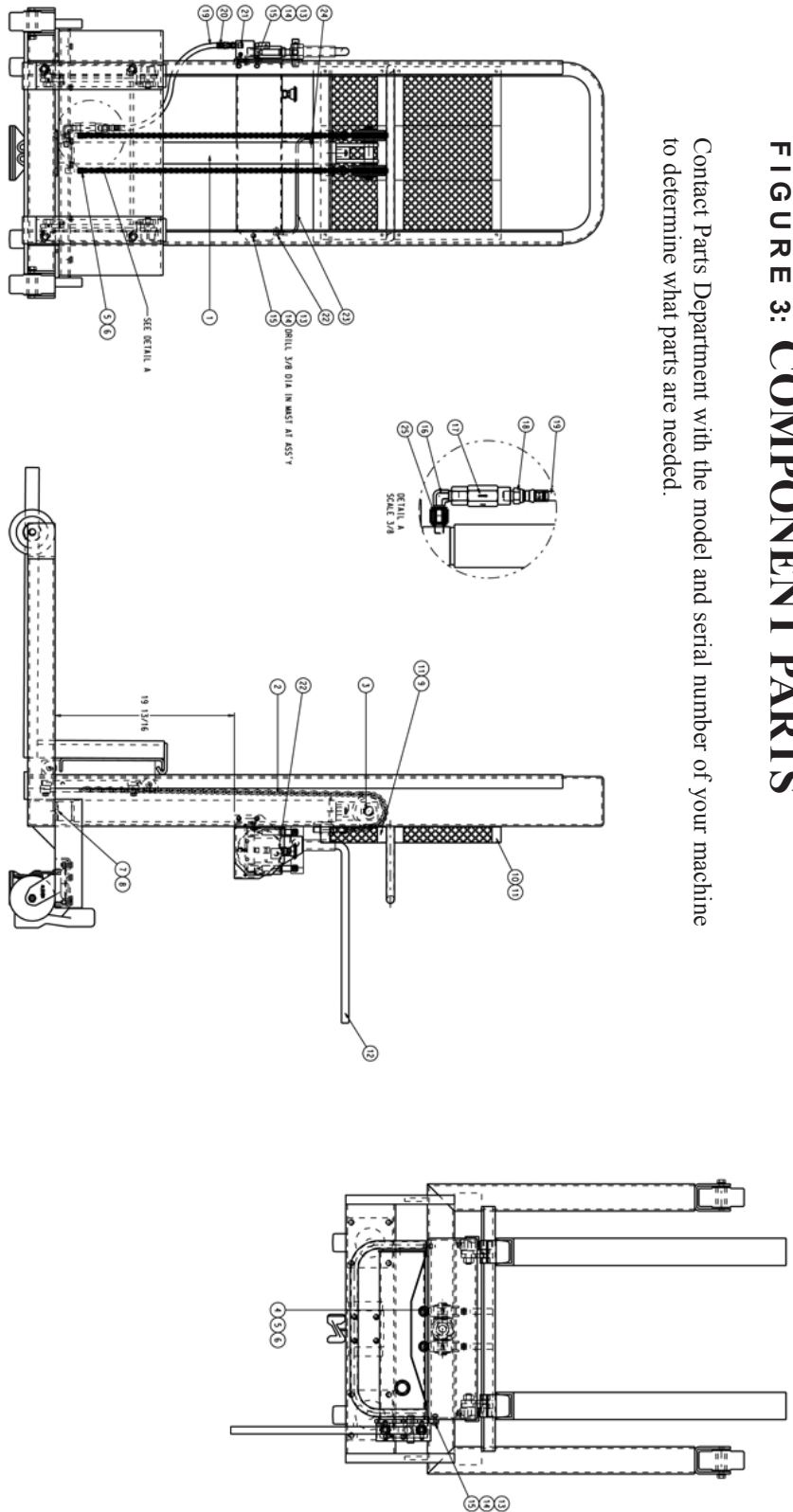

Item	Qty	Description	Item	Qty	Description
1	1	Cylinder	14	3	Screw
2	2	Chain	15	3	Lock Washer
3	1	Double Leaf Chain Roller Assy	16	1	Adapter Fitting
4	2	Chain Mtg	17	1	Valve
5	4	Pin	18	1	Hose Fitting
6	8	Split Ring	19	2	Hose
7	2	Screw	20	1	Hose Fitting
8	2	Lock Washer	21	1	Adapter Fitting
9	1	Guard	22	1	Adapter Fitting
10	1	Guard	23	2	Tube Clear
11	8	Screw	24	1	Adapter Fitting
12	1	Hand Pump	25	1	Adapter Fitting
13	3	Nut	26	1	Handle, Pump 90

FIGURE 4: HYDRAULIC CYLINDER ASSEMBLY FOR ALL ELECTRIC AND BATTERY OPERATED UNIT

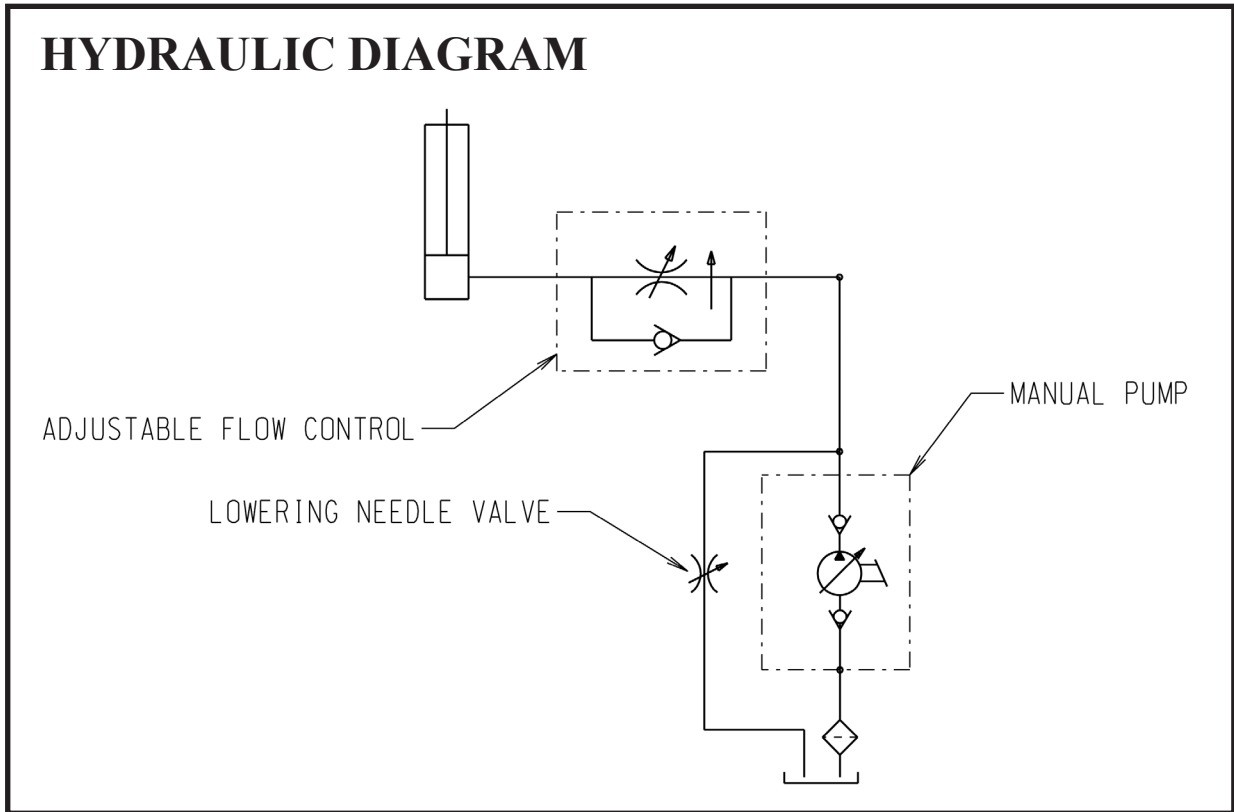

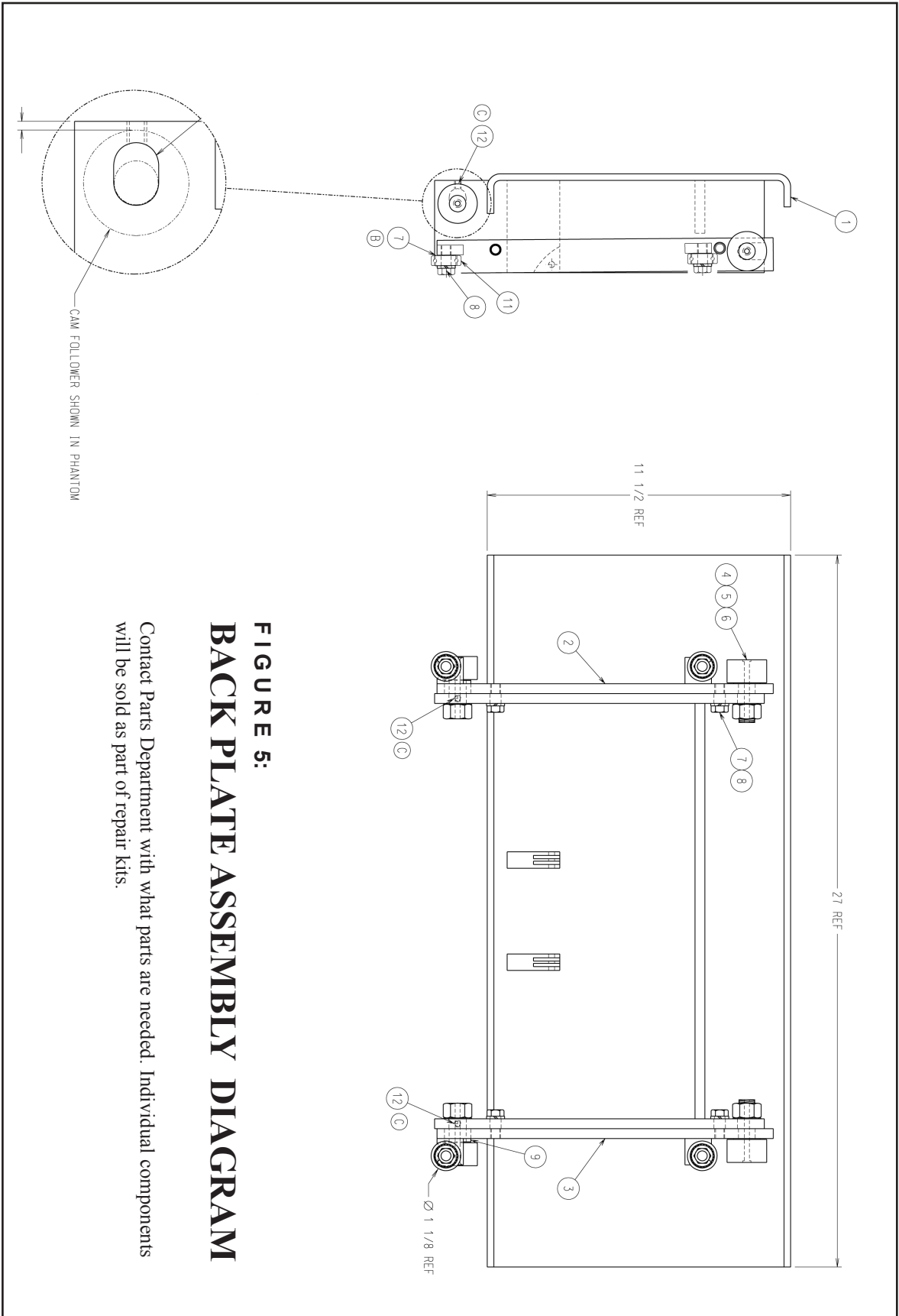

FIGURE 5:
BACK PLATE ASSEMBLY DIAGRAM

Contact Parts Department with what parts are needed. Individual components will be sold as part of repair kits.

FIGURE 6: FORK WELDMENT DIAGRAM

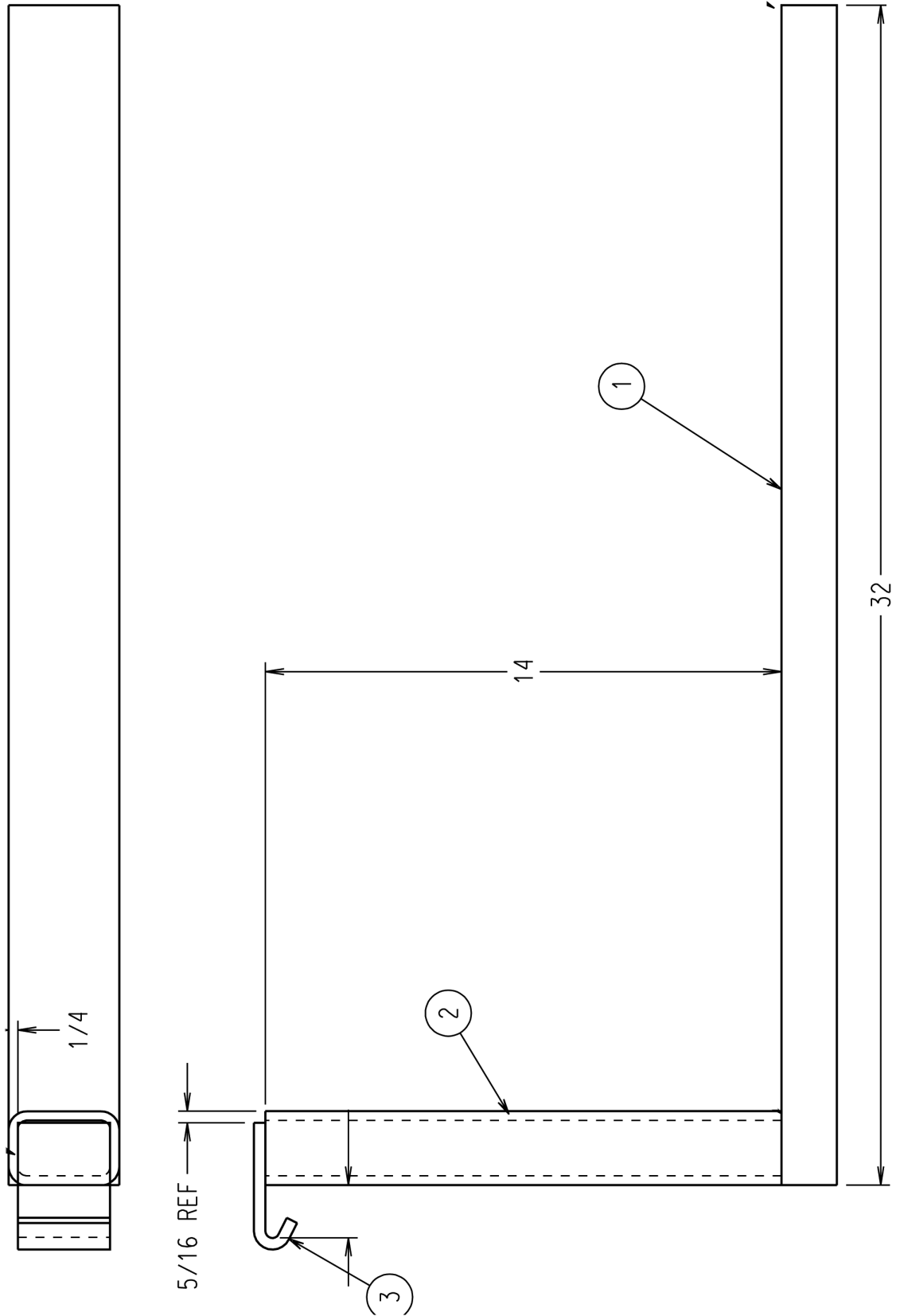
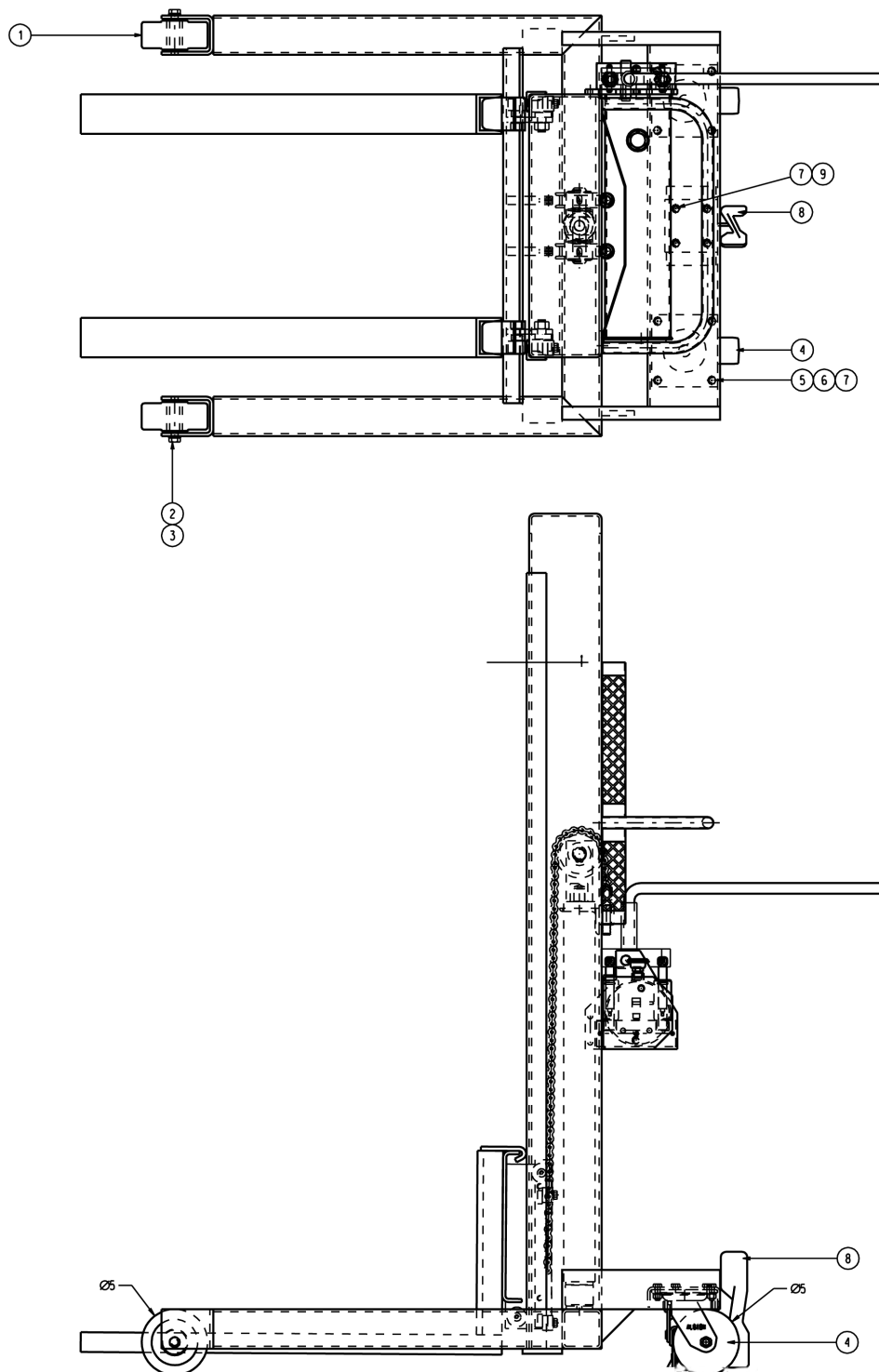

FIGURE 7: PORTABILITY PACKAGE DIAGRAM

Contact Parts Department with what parts are needed. Individual components will be sold as part of repair kits.



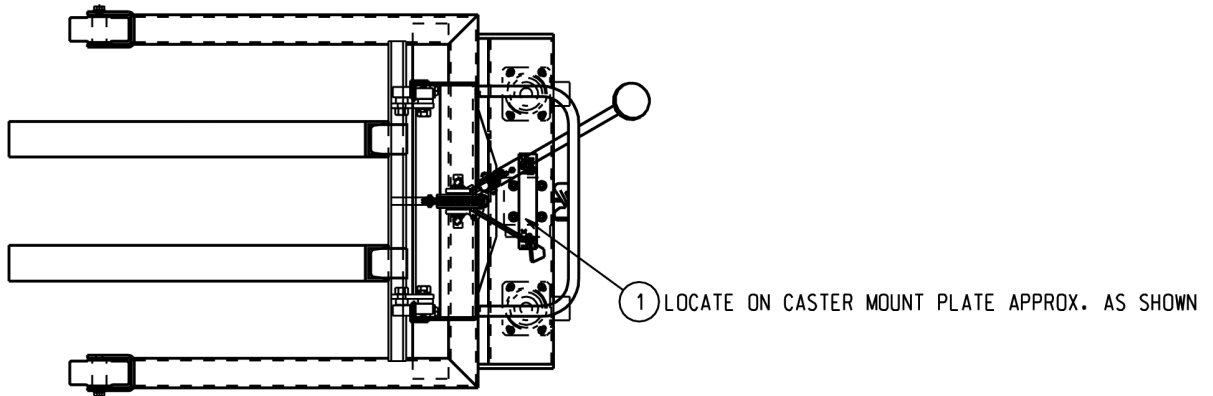

FIGURE 8: LABEL LOCATION DIAGRAM

Contact Parts Department with what parts are needed. Individual components will be sold as part of repair kits.

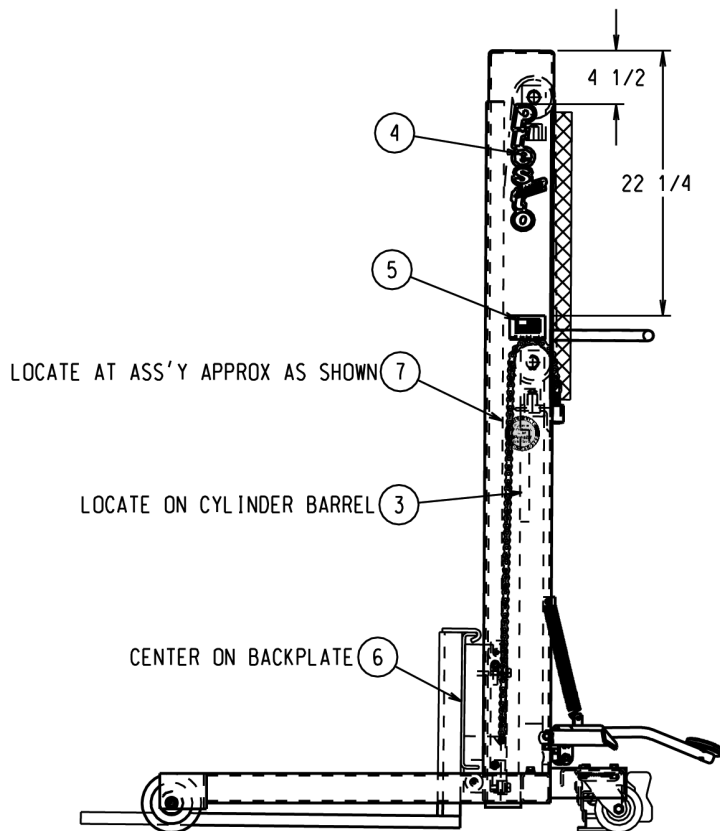

Table 1 – Hydraulic Oil Specifications

If the lift will be used at normal ambient temperatures, Presto Lifts supplies the unit with Conoco Super Hydraulic oil. This may be replaced by any other good quality oil with 150 SSU at 100° F and rust and oxidation inhibitors and anti-wear properties.

If the lift will be used at ambient temperatures below 0°F, use aircraft hydraulic oil. Use Type 15 aircraft hydraulic oil.

The following are equivalent to CONOCO SUPER HYDRAULIC 32:

TYPE	MANUFACTURER
DTE 24	EXXON/MOBIL
CITGO AW32	CITGO
NUTO H32	EXXON/MOBIL
AMOCO AW32	CHEVRON (AMOCO CO.)



It is very important to keep the hydraulic oil free of dirt, dust, metal chips, water, and other contamination. Most of the problems with hydraulic systems are caused by contamination in the oil.

Ordering Replacement Parts

Presto Lifts has carefully chosen the components in your unit to be the best available for the purpose. Replacement parts should be identical to the original equipment. Presto Lifts will not be responsible for equipment failures resulting from the use of incorrect replacement parts or from unauthorized modifications to the unit.

Presto Lifts can supply all replacement parts for your lift. With your order, please include the model number and the serial number of the unit. You can find these numbers on the name plate. This plate is located within the cabinet, or on the angle iron cylinder cross support.

To order replacement parts, please call the Presto Parts Department. Parts are shipped subject to the following terms:

- FOB factory
- Returns only with the approval of our parts department.
- Credit cards preferred (except parts covered by warranty).
- Freight collect for truck (except parts covered by warranty).
- Freight – prepaid and invoice for small parcel shipments (except parts covered by warranty).
- The warranty for repair parts is 30 days from date of shipment.

Parts replaced under warranty are on a “charge-credit” basis. We will invoice you when we ship the replacement part, then credit you when you return the worn or damaged part, and we verify that it is covered by our warranty. Labor is not covered under warranty for Parts orders.

Presto Parts Department
50 Commerce Way, Norton, MA 02766
Telephone: 800-343-9322 • FAX: 888-788-6496
Email: service@PrestoLifts.com
www.PrestoLifts.com

PARTS

Standard parts may be returned with a 20% restocking fee or \$35.00 net, whichever is greater. Modified or custom-engineered parts are not returnable. Unfortunately, due to potentially concealed damage, all sales of electrical assemblies are final.

QUALITY ISSUES

Should you feel there is a quality problem, please contact the seller to ask questions and gather information on how to rectify the issue. Presto Lift Inc. reserves the right to determine potential credits, as a result of factory defects, based on its inspection of the merchandise.

GENERAL

All products shipped from our factory have passed Quality Assurance inspection and testing. The carrier of choice has signed for, and accepted the product in new working condition. The customer should inspect to ensure it is not received damaged, has no concealed damage or is not incomplete. Parts orders are determined to be complete based upon Presto Lift, Inc. inspection sheets and carrier shipping weights.

RETURN GOODS AUTHORIZATION POLICY

Presto Lifts provides the Return Goods Authorization (RGA) Policy, for specific models, as a courtesy to our distributors in the event they do not receive what they ordered. If a customer wishes to return a Presto Lifts product, please contact the Customer Service Department and request an RGA number. This request must be made on or before the fifteenth calendar day following the date of Presto Lifts' invoice for the merchandise. Not all units are returnable. Quantity orders and special designs cannot be returned under any circumstances. Presto Customer Service reserves the right for final judgment on all product returns.

The RGA number must appear on the outside of any packaging material for a return to be accepted and processed by Presto Lifts. Customers shipping returns from the Continental US, Canada, or Mexico have thirty (30) days from date of RGA issue to have the product arrive at Presto Lifts' facility. All merchandise must arrive Free on Board at Presto Lifts' facility or the shipment will be refused and returned to the sender. All credits are issued less restocking and refurbishing charges, regardless if the merchandise was damaged in transit.

Return addresses: please refer to your RMA for the address to which your product should be returned.

Presto Lift Inc.
715 Highway 77
Manila, Arkansas 72442

Telephone: 800-343-9322
Fax: 888-788-6496

Presto Lifts Limited Warranty Policy

Presto Lifts warrants all of its products against defects in the welded structural frame and, if applicable, scissor legs from faulty material and workmanship for a period of five (5) years from the date of invoice.

All other components have a limited warranty against defects in faulty material and workmanship for a two (2) year period from the date of invoice and 30 day limited warranty on labor. Please note that prior authorization from Presto Lifts is required on all warranty work.

There are no implied warranties of any kind, more specifically, there are no warranties of merchantability or fitness for any particular purpose. Presto Lifts' sole warranty shall be as set forth in this limited warranty.

Presto Lifts will elect to repair or replace a defective component without charge, if any components should become defective within the limited warranty period. Proof of purchase is required for warranty. The charge for shipping the defective component is the responsibility of the buyer and must be accompanied with an RMA number. The shipping charge to return the component to the buyer is the responsibility of Presto Lifts, Inc.

This limited warranty does not cover labor expense for removal or reinstallation of components after thirty days. This limited warranty shall not cover, among other things: damages resulting from foreign matter or water, failure to provide reasonable and necessary maintenance, and if applicable, use of product while charger is plugged into an AC outlet, or failure to follow operating instructions. The limited warranty is not valid for damage resulting from negligence, accident, unreasonable use, abuse or misuse, exceeding data plate capacities or altering the product without Presto Lifts authorization.

Presto Lifts expressly disclaims and excludes any liability for consequential, incidental, indirect or punitive damages or financial loss to people or property resulting from any breach of warranty or the operation or failure of this product.

Presto Lifts makes no representation that this product complies with local, state, or federal safety/product standards codes. Should this product fail to comply in any way with those codes, it shall not be considered a defect of materials or workmanship. Presto Lifts shall not be held liable for any damages resulting from noncompliance. It is the dealer's responsibility to exercise this limited warranty. This limited warranty is provided to the original purchaser (defined as the original end user) and is nontransferable. This constitutes the complete and final agreement involving Presto Lifts and limited warranty obligations for products.

MANY NEEDS REQUIRE MANY OPTIONS...

Presto ^{LIFTS}



LET PRESTO MEET THOSE NEEDS!

Call Presto Sales
for stock or
customized lift inquiries:
800-343-9322

Email: sales@prestolifts.com

