



# **LIFT-STIK**

## **Compact Lift Stacker**

### **PLS53-150**

(For equipment shipped after January 2023)



Model: \_\_\_\_\_  
Serial Number: \_\_\_\_\_  
Date placed in service: \_\_\_\_\_

Presto Lifts Inc., 2 Hampshire Street, Suite 102, Foxborough, MA 02035  
800.343.9322 | Fax: 888.788.6496  
service@prestolifts.com  
www.PrestoLifts.com

**Owner Manual**

# Contents

If viewing this manual electronically, just left click any section below to immediately view that area.

To get back to the table of contents, just click in area to the outside of the left border.

<b>1</b>	<b>INTRODUCTION.....</b>	<b>4</b>
1.1	Responsibilities of Owner and Users .....	4
1.2	Responsibilities of Operators .....	5
1.3	General Description .....	8
1.4	Construction and Materials .....	8
1.5	Identifying the LiftStik.....	9
1.6	Specifications.....	10
1.7	Loading .....	10
1.8	Exception of Liability .....	10
<b>2</b>	<b>SAFETY .....</b>	<b>11</b>
2.1	Safety Alert Symbols.....	11
2.2	Signal Words.....	11
2.3	Typographic Convention .....	12
2.4	General Safety Precautions During Use .....	13
2.5	Residual Risks .....	14
<b>3</b>	<b>LABELS .....</b>	<b>15</b>
<b>4</b>	<b>INSTALLATION .....</b>	<b>16</b>
<b>5</b>	<b>OPERATION.....</b>	<b>19</b>
5.1	Safety Areas and Distance.....	21
5.2	Batteries, Connectors, and Chargers.....	22
<b>6</b>	<b>APPLICATION TOOL.....</b>	<b>25</b>
6.1	Platform and Frame (HDPE Plastic) .....	25

<b>7</b>	<b>MAINTENANCE AND INSPECTION .....</b>	<b>26</b>
7.1	Daily Checks .....	27
7.2	Semi-Annual Checks .....	28
7.2.1	Critical Components .....	28
7.3	Cam Belt Adjustment .....	29
7.4	Cam Belt and Sprocket Replacement.....	31
7.5	Disposal .....	37
<b>8</b>	<b>CLEANING INSTRUCTIONS.....</b>	<b>38</b>
<b>9</b>	<b>RESOLVING FAULTS .....</b>	<b>39</b>
<b>10</b>	<b>ELECTRICAL SCHEMATIC - SOFTSTART.....</b>	<b>40</b>
<b>11</b>	<b>SPARE PARTS .....</b>	<b>41</b>
11.1	Mast Complete.....	41
11.2	Mast .....	42
11.3	Handle.....	43
11.4	Standard Legs - Angled .....	44
<b>12</b>	<b>ANNUAL INSPECTION .....</b>	<b>45</b>
<b>13</b>	<b>WARRANTY &amp; CONTACT INFORMATION .....</b>	<b>46</b>

This manual was current at the time of printing. To obtain the latest, most updated version, please contact the Customer Service Department or go to our website: [www.PrestoLifts.com](http://www.PrestoLifts.com). You will find a complete list of current Owner Manuals to print.

<b>⚠ WARNING</b>
Cancer and Reproductive Harm - <a href="http://www.P65Warnings.ca.gov">www.P65Warnings.ca.gov</a>

This label (part # 10095524) is required by California Law. For more information visit:  
[www.P65Warnings.ca.gov](http://www.P65Warnings.ca.gov)

# 1 INTRODUCTION

This manual attempts to provide all of the information necessary for the safe and proper installation, operation and maintenance of the Presto Lifts Lift Stik. It is important that all personnel involved with the installation, maintenance or operator of the stacker read this manual. Additional manuals are available upon request or at [www.prestolifts.com](http://www.prestolifts.com).

Each of the Presto Lifts stackers is equipped with nameplate, serial number and model identifications. Please refer to these numbers when ordering parts or requesting further information.

The Presto Lifts stackers are designed for lifting, lowering and positioning a wide variety of loads. Where unique situations arise which are not covered in this manual, call Presto Lifts for further instructions.

The battery-operated stackers are designed for in-plant/non-hazardous locations only. These units are not for personnel lifting. All equipment is manually propelled and powered vertical travel.

## 1.1 Responsibilities of Owner and Users

**Basic Principles** - Owners/users shall apply sound principles of safety, training, inspection, maintenance to the expected operating environment. It shall be the responsibility of the owner/user to advise the manufacturer where deflection may be critical to the application.

**Manuals** - Owners/users shall keep and maintain a copy of the operating and maintenance manual(s) and ensure its availability to operating and maintenance personnel.

**Inspection and Maintenance** - It shall be the responsibility of the users to inspect and maintain the machine as required to ensure proper operation. The frequency of inspection and maintenance shall be based upon the manufacturer's recommendations and be compatible with operating conditions and the severity of the operating environment. Machinery that is not in proper operating condition shall be immediately removed from service until repaired. Maintenance and repairs shall be made by a qualified person and the repairs shall be in conformance with the manufacturer's recommendations.

**Maintenance Safety Precautions** - Before adjustments and repairs are started on the machine, the following precautions shall be taken as applicable:

1. Remove the load from the platform.
2. Lower platform to the full down position.
3. All controls in the "off" position and all operating features secured from inadvertent motion by brakes, blocks, or other means.
4. Disconnect power and follow established owner/user lockout/tag out policies.
5. Follow precautions and directions as specified by the manufacturer.

**Replacement Parts** - When parts or components are replaced, they shall be replaced with parts or components approved by the original manufacturer.

**Maintenance Training** - The user shall ensure only qualified personnel inspect and maintain the machine in accordance with the manufacturer's recommendations.

**Operator Training** - An owner/user, who directs or authorizes an individual to operate the machine shall ensure that the individual has been:

1. Trained in accordance with the manufacturer's operating manual.
2. Made aware of the responsibilities of operators as outlined in section 1.2 of this manual.
3. Retrained, if necessary, based on the owners/user's observation and evaluation of the operator.

**Modifications** and additions shall not be performed without the manufacturer's prior written approval. Where such authorization is granted, capacity, operation, and maintenance instruction plates, tags, or decals shall be changed accordingly.

## 1.2 Responsibilities of Operators

**Basic Principles** - Operators shall apply sound principles of safety and good judgment in the application, and operation of the machine with consideration given to its intended use and expected operating environment. Since the operator is in direct control of the machine, conformance with good safety practices is the responsibility of the operator. The operator shall make decisions on the use and operation with due consideration for the fact that his or her own safety as well as the safety of other personnel on or near the machine is dependent on those decisions.

**General Training** - Only personnel who have received general instructions regarding the inspection, application, and operation of machine, including recognition and avoidance of hazards associated with their operation, shall operate the machine. Such topics covered shall include, but not necessarily be limited to, the following issues and requirements:

1. A pre-start inspection
2. Responsibilities associated with problems or malfunctions affecting the operation of the machine
3. Factors affecting stability including moving the machine with the platform as low as possible.
4. The purpose of placards and decals
5. Workplace inspection
6. Safety rules and regulations
7. Authorization to operate
8. Operator warnings and instructions
9. Actual operation of the machine. Under the direction of a qualified person, the trainee shall operate the machine for a sufficient period of time to demonstrate proficiency in actual operation of the machine.

**Pre-start Inspection** - Before use each day or at the beginning of each shift, the machine shall be given a visual inspection and functional test including but not limited to the following:

1. Operating and emergency controls
2. Safety devices
3. Electrical cables and wiring harness
4. Loose or missing parts
5. Nameplates, precautionary and instructional markings and/or labeling
6. Guarding system
7. Items specified by the manufacturer

**Problem or Malfunctions** - Any problems or malfunctions that affect the safety of operations shall be repaired prior to the use of the machine.

**Before Operations** - The operator shall:

1. Read and understand the manufacturer's operating instruction(s) and user's safety rules or have them explained.
2. Understand all labels, warnings, and instructions displayed on the machine or have them explained.

**Workplace Inspections** - Before the machine is used and during use, the operator shall check the area in which the machine is to be used for possible hazards such as, but not limited to:

1. Bumps, floor obstructions, and uneven surfaces
2. Overhead obstructions and electrical hazards
3. Presence of unauthorized persons
4. Other possible unsafe conditions as noted in the operating manual.

**Operator Warnings and Instructions** - The operator shall ensure the operation of the machine is in compliance with the following:

1. **Guarding system** - Guarding shall be installed and positioned, and access gates or openings shall be secured per the manufacturer's instructions (If applicable).
2. **Distribution of load** - The load and its distribution on the platform shall be in accordance with the manufacturer's rated capacity for that specific configuration.
3. **Maintaining overhead clearance** - The operator shall ensure that adequate clearance is maintained from overhead obstructions and energized electrical conductors and parts.
4. **Point of Operation** - The operator shall not place any part of their body under the platform.
5. **Precaution for moving equipment** - When other moving equipment or vehicles are present, special precautions shall be taken to comply with the safety standards established for the workplace.
6. **Reporting problems or malfunctions** - The operator shall immediately report to a supervisor any problem(s) or malfunction(s) that become evident during operation. The operator shall ensure all problems and malfunctions that affect the safety of operations are repaired prior to continued use.
7. **Capacity limitation** - Rated capacity and load center shall not be exceeded when loads are transferred to the platform.

8. **Work area** - The operator shall ensure the area surrounding the machine is clear of personnel and equipment before lowering the platform.
9. **Securing the machine** - The operator shall comply with the means and procedures provided to protect against use by an unauthorized person(s).
10. **Altering safety devices** - Safety devices shall not be altered or disabled.
11. **Modifications** or alterations of the machine or the fabrication and attaching of frameworks or the mounting of attachments to the machine or the guarding system shall only be accomplished with prior written permission of the manufacturer.
12. **Assistance to the operator** - If an operator encounters any suspected malfunction or any hazard or potentially unsafe condition relating to capacity, intended use, or safe operation, the operator shall cease operation of the machine and request further instruction from the owner/user.
13. **Problems or malfunctions** - Any problem(s) or malfunction(s) that affect the safety of operations shall be repaired prior to the use of the machine.

### 1.3 General Description

A Presto Lifts/ECO A lifter is a battery-operated lifting device moved around manually, used to handle a wide variety of items to reduce heavy and unnatural lifting from personnel, the intention is to improve work life in regards of personal health and safety.

It is important that the lifter as a whole is configured correctly to handle the required load with respect to the load type, the load center of gravity and the lifting height to achieve a safe balance and operation.

The lifter consists of 2 main components:

#### 1. Mast

- The mast is a lifting column, optional in different heights which is mounted on a set of “legs” and used to lift the platform suitable for the customers’ requirements.
- The lifting function is gained from an electric motor through a cambelt which is moving a sledge inside the mast profile.
- The connection between the motor and the cambelt is through a “one-way bearing” which is a built-in safety feature; hence the sledge is lowered only by gravity and not forced downwards by the motor.
- The platform is mounted on the sledge with bolts.

#### 2. Legs

- The legs are used to hold the mast in a vertical position and mounted with wheels so that the lifter can be manually moved around on a flat, level floor.
- It is vital that the legs are configured correctly, with the main purpose of keeping the lifter stable and safe on the floor in the specific configuration of platform, weight, center of gravity of the load and lifting height.
- The mast is mounted on the legs with bolts.

### 1.4 Construction and Materials

All materials are suitable for use in production, retail, service and distribution.

Part	Material
Mast	Aluminium (AlMg3).
Handle	Powder-coated steel (1.0037 / S235)
Sledge	Electro-galvanized steel (1.0037 / S235)
Cover for control box	Powder-coated steel (1.0037 / S235)
Remote	Polyamide 6
Wheel frame	Powder-coated steel (1.0037 / S235)
Front wheels	Polyurethane
Back wheels	Polyamide and Polyurethane



## 1.5 Identifying the LiftStik

The information contained in this manual covers LiftStiks shipped after January, 2023. For machines shipped before February, 2023, please contact customer service. If you are not sure of the date that you actually received your LiftStik, the following images should help you discern this.

Majority of LiftStiks shipped after January 2023 look like this.  
Use this manual.

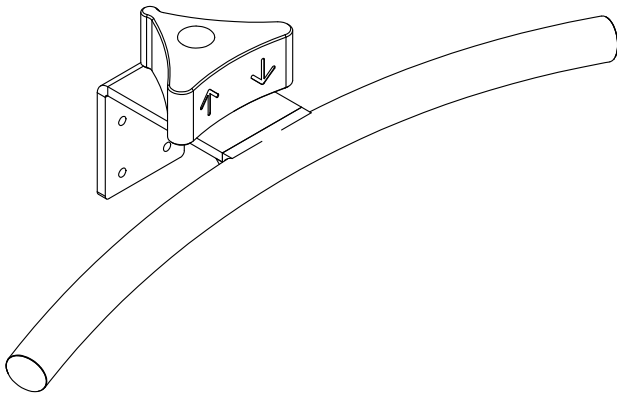

The DC charger input receptacle has a silver outer ring.

Majority of LiftStiks shipped before January 2023 look like this.  
Contact customer service.

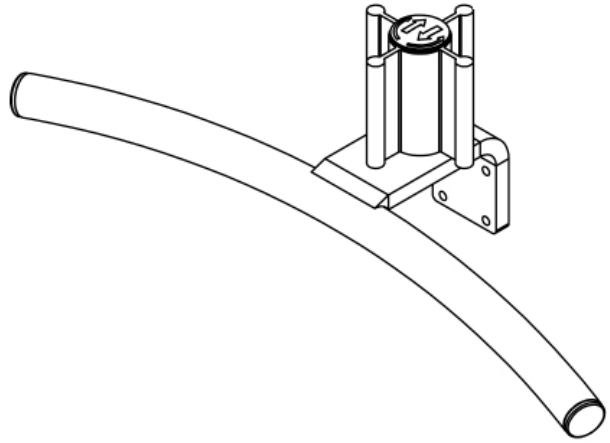

The DC charger input receptacle has a black plastic outer ring.

Differences between the previous and current machines include the controller style, the DC input charging receptacle in the mast, the electrical diagram and a few part numbers.

## 1.6 Specifications

	<b>PLS53-150</b>
<b>Weight (lb/kg)</b>	56/25
<b>Raised Height (in/mm)</b>	53/1346
<b>Lifting Height (in/mm)</b>	48.5/1233
<b>Max Load (lb/kg) and Load Center of Gravity</b>	150 lb/70 kg - 9.5 in/240 mm from mast for typical platform (If other than typical platform, consult Presto Service if not labeled)
<b>Lifting Speed</b>	4 - 5 in/s or 100 - 125 mm/s
<b>Protection Class</b>	IP41
<b>Batteries</b>	24v DC, 7.2 Ah
<b>Charger</b>	100 - 240 V, 50/60 Hz - 2 Amps
<b>Charging Time</b>	4 hours (80%), 5 hours (100%)
<b>Sound Pressure Level</b>	< 70 DB(A)
<b>Vibration Strength</b>	< 2.5 m/s <sup>2</sup>

## 1.7 Loading

The max load is indicated on each individual lifter and the max weight for the platform is indicated on the platform. Consult Presto Service if not labeled. For the standard PLS53-150 lifter with platform, the load center of gravity of the max load of 150 lb/70 kg is to be no further than 9.5 in/240 mm from the mast.

## 1.8 Exception of Liability

- Presto Lifts/ECOAs cannot be held responsible for any modifications on the lift or attached equipment, not authorized by Presto Lifts/ECOAs.
- Do only use original spare parts, otherwise Presto Lifts/ECOAs cannot be held liable for the function and safety of the lift.
- The lifter must only be serviced by a qualified technician, otherwise Presto Lifts/ECOAs cannot be held liable for the function and safety of the lift.

## 2 SAFETY

All personnel installing, operating, and maintaining this machine shall read and understand this manual. For questions or concerns contact the manufacturer.

### 2.1 Safety Alert Symbols



A symbol that indicates a hazard. It is composed of an equilateral triangle surrounding an exclamation mark. The safety alert symbol is only used on hazard alerting signs. It is not used on safety notice and safety instructions signs.

**A** – For use with **DANGER** signal word; (safety white triangle, safety red exclamation mark, safety red background)

**B** – For use with **WARNING** signal word; (safety black triangle, safety orange exclamation mark)

**C** – For use with **CAUTION** signal word; (safety black triangle, safety yellow exclamation mark)

**D** – For use with **DANGER, WARNING, or CAUTION** signal words; (**D** is a safety yellow triangle with a safety black border and safety black exclamation mark;

### 2.2 Signal Words

#### **DANGER**



**DANGER** Indicates a hazardous situation that, if not avoided, will result in death or serious injury.

#### **WARNING**



**WARNING** Indicates a hazardous situation that, if not avoided, could result in death or serious injury.

#### **CAUTION**



**CAUTION** Indicates a hazardous situation that, if not avoided, could result in minor or moderate injury.

#### **NOTICE**



**NOTICE** Indicates information considered important, but not hazard-related (e.g., messages relating to property damage).

This machine shall be installed, operated, and maintained by trained and/or qualified personnel only. In order to provide for the safe operation of these stackers, Presto Lifts has identified certain hazards that may occur during the installation, maintenance and use of these lifts. For safety reasons these units are designed to be serviced or repaired in the fully lowered position. If performed properly, this will greatly reduce the possibility of injury.

## 2.3 Typographic Convention

The following cautionary symbols may be used in the manual and / or on the lift.



**Warning!**

This pictogram draws attention to the risk of personal injury.



**Warning!**

This pictogram draws attention to the risk of personal injury.

- There is a risk of getting your fingers crushed.



**Warning!**

This pictogram draws attention to the risk of personal injury.

- The lifter must not be used for lifting persons.



**Warning!**

This pictogram draws attention to the risk of personal injury.

- There should be no body parts below or near the lifting tool when operated up or down.



**Warning!**

This pictogram draws attention to the risk of personal injury.

- There should be no body parts on top of the front legs steel profile, when the lift is elevated or operated.



This pictogram is posted on the lifter, if the lifter is antistatic. (Option)

## 2.4 General Safety Precautions During Use

The following guidelines must be observed and followed when using a lift, to prevent personal injury:



- Under no circumstances should the lift elevate more than specified on the label.
- It is of most importance, due to personal safety, that the specified weight, load position, and height are respected and that the lift is not overloaded.



- The lift must not be used for lifting persons.



- No body parts near the sledge or tool at the mast or other lifting equipment when operated up/down.



- Ensure that there is no person below the load, tool and lift when operated.



- There should be no body parts on top of the front legs steel profile, when the lift is elevated or operated.



- Only one person must operate the lift at a time.
- The user must read and understand these instructions or must have them explained to them before using the lifter.
- Only use the lift when operated on a hard level surface during lifting or transporting loads.
- When transporting cargo, the load should be lowered to the lowest possible position and secured in order to ensure that the cargo cannot slide.
- Always secure the cargo on the lift when moving.
- Note when not in use or storing, always ensure that the sledge is lowered to the lowest possible position and is free of any items or cargo.
- Operate and store in a clean, dry location with temperature from +5 °C to +40 °C.
- Make sure that the tool is firmly attached to the sledge and no slack occurs in the bolt connection.
- The lifter is to be inspected at least once a year or according to laws, regulations, directives, working conditions and experience. The inspection shall be performed by the manufacturer or a skilled technician. Please check your local requirements.
- Do not lift or handle open containers containing corrosive fluids, harmful to people if spilled.
- Light industrial, commercial, laboratory, and office applications.
- Indoor use only.
- Do not use the lifter in explosive or flammable hazard environment.
- Do not use or store in a corrosive environment.
- The load's center of gravity to be no further than 9.5in/240 mm from the mast.
- The lifter should only be cleaned by wiping with a damp cloth, otherwise water may enter into contacts and control panel.
- The cam belt should be replaced every 8 years or sooner if worn.

## 2.5 Residual Risks

There are residual risks for extraordinary wear, material or product failure due to great impact from collision, misuse, obstacle interference, blockade of driveways, etc.; e.g. a faulty wheel bearing, as a result of a heavy collision.



### Residual risk for personnel working with or around the lifter

**A:** Do not use the lifter or tool with unstable, unbalanced load.

**B:** No persons or body parts must be put under the tool.

**C:** Do not put objects or limbs (feet, hands, fingers etc.) into any opening of the lifter.

**D:** Do not put limbs (feet, hands, fingers etc.) in the front wheel.

**E:** Do not put limbs (feet, hands, fingers etc.) in the back wheel.

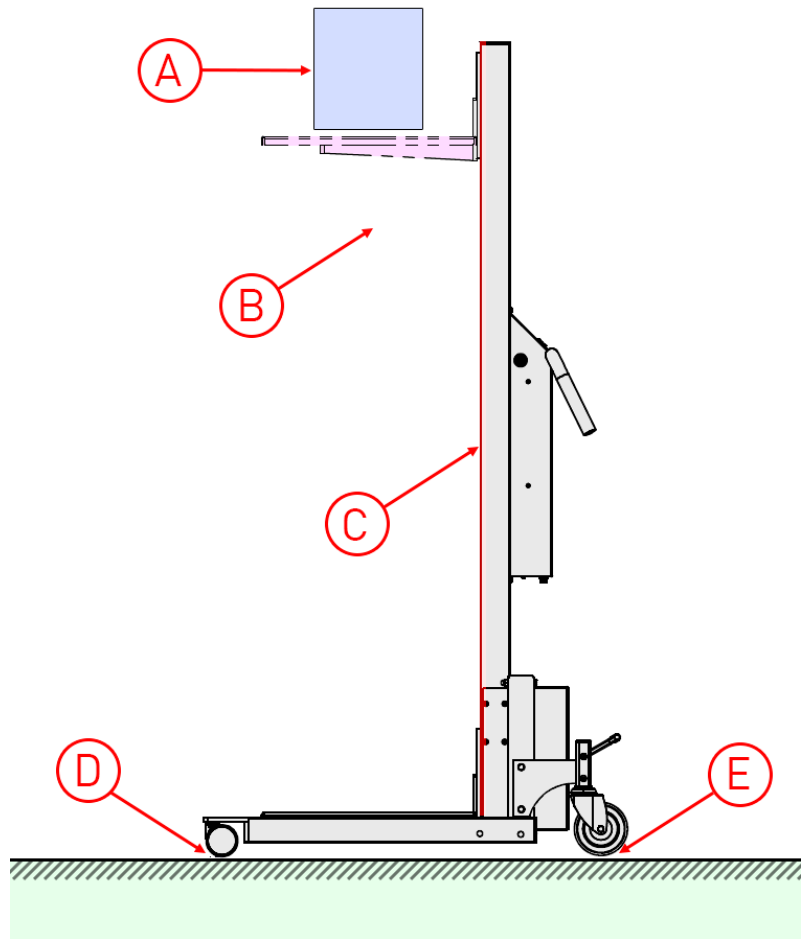

Example:

● Load

● Tool

● Lifter

● Ground

## Shipping







### When shipping the lifter:

- The sledge must be lowered to the lowest possible position and be free of any items or cargo.
- Fasten the lifter securely during transport.

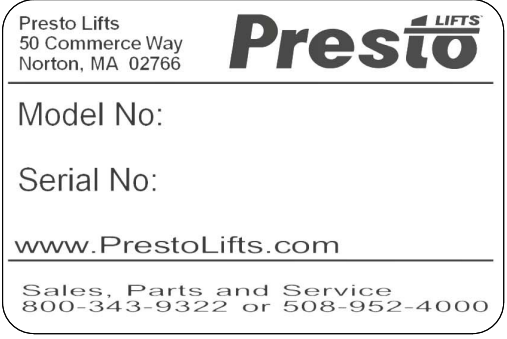
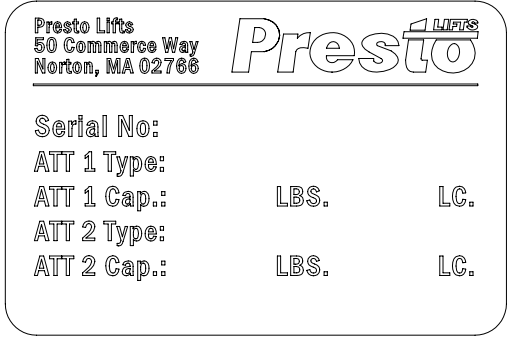
### 3 LABELS

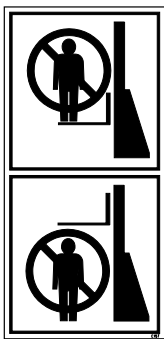
If any of the labels below become illegible, contact Presto Lifts Parts Department to order replacement ones.

Item 1	Located on back side of mast (Part # 10079930)	Item 2	Located on back side of mast (Part # 10115264)
Serial ID		Capacity	
 <p>Presto Lifts 50 Commerce Way Norton, MA 02766</p> <p><b>Presto</b> <small>LIFTS</small></p> <p>Model No:</p> <p>Serial No:</p> <p><a href="http://www.PrestoLifts.com">www.PrestoLifts.com</a></p> <p>Sales, Parts and Service 800-343-9322 or 508-952-4000</p>		 <p>Presto Lifts 50 Commerce Way Norton, MA 02766</p> <p><b>Presto</b> <small>LIFTS</small></p> <p>Serial No:</p> <p>ATT 1 Type:</p> <p>ATT 1 Cap.:           LBS.           LC.</p> <p>ATT 2 Type:</p> <p>ATT 2 Cap.:           LBS.           LC.</p>	
Item 3	Located on back side of mast (Part # 30000414)	Item 4	Located on back side of mast (Part # 10095524)
Help Line		Warning Cancer and Reproductive	
 <p><b>HELP LINE</b></p> <p>If you are not satisfied in any way contact</p> <p><b>Presto</b> <small>LIFTS</small></p> <p>Parts or Service</p> <p><b>1-800-343-9322</b></p>		 <p><b>⚠ WARNING</b></p> <p>Cancer and Reproductive Harm -</p> <p><a href="http://www.P65Warnings.ca.gov">www.P65Warnings.ca.gov</a></p> <p>10095524</p>	
Item 5	Located on back side of mast (Part # C157)	Item 6	Located on right and left sides of mast (Part # 10116671)
Serial Number		Lift Stik Label	
 <p>Two safety icons showing a person standing on a lift platform with a red prohibition sign over them, indicating that personnel should not stand on the platform.</p>		 <p><b>← Lift Stik →</b></p>	

## 4 INSTALLATION

Setup of this machine shall be performed by trained and/ or qualified personnel only. The owner/ installer is responsible obtaining any necessary permission and/ or permits. The owner/ installer is responsible for compliance with all applicable codes and ordinances. Read and understand all safety and installation information in this manual.

Unless otherwise stated this machine shall only be used indoors in light industrial, commercial, laboratory, and office applications. It should not be exposed to the elements. It shall be setup and operated on a solid, smooth and level surface capable of supporting the machine and its maximum rated capacity.

Before setup, remove all shipping materials and verify all components on the packing list were received. Inspect the machine, all components, wiring, electrical connections for damage. Presto Lifts tests and inspects every piece of equipment prior to shipment. If damage is apparent, a freight claim must be filed with the freight company. If components are missing, contact the freight company and/or the manufacturer before continuing installation.

With the lift in a lowered position, check for signs of damage especially to the back cabinet that houses the battery and power pack, check base frame for dimensions and structural integrity, inspect for any bent or damaged metal parts, check to see if the wheel locking system is in working condition, ensure battery cables are connected to the batteries and ensure the batteries are fully charged before using. See **Batteries, Connectors, and Chargers** section.

### **DANGER**

**High Voltage: Electrical service and installation must be performed by trained and/ or qualified personnel. Disconnect the charger before repairing the Lifter. The charger is equipped with an AC electric cord having an equipment-grounding conductor and ground plug. Never alter this cord/plug. It must be inserted into a properly installed/specified outlet in accordance with all local codes and ordinances. DC motors and AC chargers can create sparks. Do not set up this machine in an area where flammable gases may be present.**

**All electrical components must be protected from wet and/or dirty environments unless specifically configured for such environments.**

**Pinch points and Crush Hazards exist when moving and transporting the machine. Do not enter under any equipment while moving or transporting. Keep hands, feet, and loose clothing away from moving equipment.**

**Never enter beneath the platform unless the machine is unloaded and secured against lowering.**

**Loads that may shift during operating must be secured before operating.**

**Keep hands, feet, and loose clothing away from moving parts.**



**⚠ CAUTION**

No personnel are permitted on the platform. Do not sit, stand, or ride.

Do not load or unload the machine while moving.

Engage rear wheel brakes before lifting, lowering, or using as a workstation.

When transporting a load, it shall be lowered to the lowest possible position and secured to ensure the load cannot slide.

This machine does not have safety toe guard protection.

The load's center of gravity must be maintained within the area indicated in the Loading section. Uneven or off-center loading may cause excessive wear or permanent damage or the load could fall and cause injury.

1. After removing all shipping materials, ensure the on/off pushbutton switch is off. The off position is out.

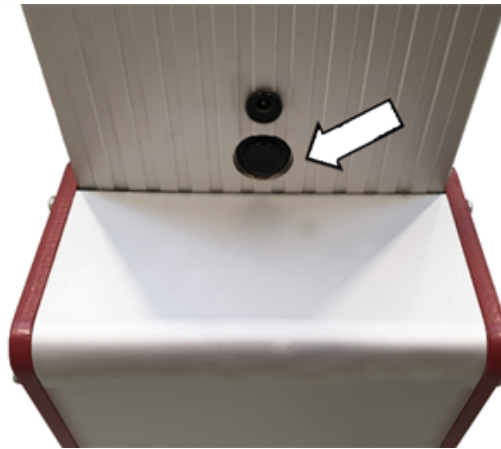

2. Remove the shipping bracket spacer placed between the commander & handle bar bracket and the mast by removing the (4) bolts.

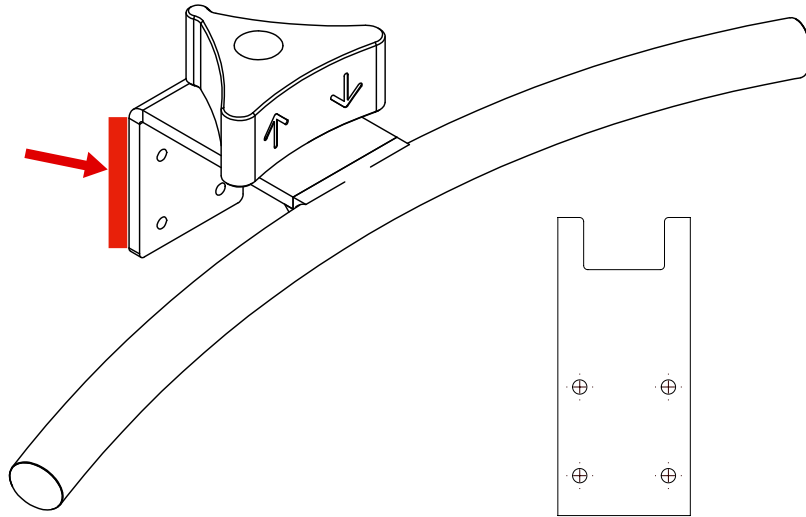

3. Once this shipping bracket spacer is removed, reinstall the handle bracket to allow the lifter platform to raise and lower.
4. Fully charge the lifter. See **Batteries, Connectors, and Chargers** section.
5. Disconnect the battery charger.
6. It is now ready for operation.

## 5 OPERATION

This machine is to be operated by trained and/or qualified personnel only.

Before operating this machine, read and understand this manual. Inspect the machine for excessive wear and/ or damage. If excessive wear or damage is found, remove the machine from service and contact maintenance personnel. Do not operate this machine until all necessary repairs are completed. Inspect all precautionary labeling. If any label is missing or illegible contact the manufacturer for replacement labels. Ensure area is free of debris.

### **DANGER**

**Pinch points and Crush Hazards exist when moving and transporting the machine. Do not enter under any equipment while moving or transporting. Keep hands, feet, and loose clothing away from moving equipment.**

**Never enter beneath the platform unless the machine is unloaded and secured against lowering.**

**No personnel are permitted on the platform. Do not sit, stand, or ride.**

**Loads that may shift during operating must be secured before operating.**

**Keep hands, feet, and loose clothing away from moving parts.**

**Do not enter beneath any platform until the load has been removed and the platform has been secured.**

**Do not load or unload the machine while moving.**

**Engage rear wheel brakes before lifting, lowering, or using as a workstation.**

**The load's center of gravity must be maintained within the area indicated in the Loading section. Uneven or off-center loading may cause excessive wear or permanent damage or the load could fall and cause injury.**

**When transporting a load, it shall be lowered to the lowest possible position and secured to ensure the load cannot slide.**

**Visually inspect the unit for damage before each use.**

## Power ON / OFF switch

Turn ON the lifter to use. (Pushbutton pushed in for ON.) Turn OFF when not in use.

### NOTICE

⋮ **Note:** It is recommended that when the lift is not in use it be placed on the charger.  
⋮

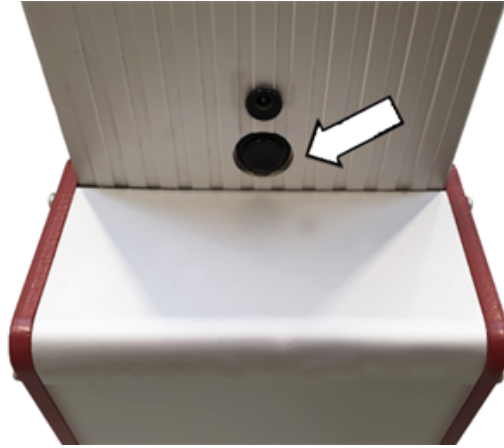

## Commander - Simple tool

This is used to operate the lifting and lowering function.

Press and hold the up arrow to raise the platform.

Release to stop the platform.

Press and hold the down arrow to lower the lifter.

Release to stop the platform.

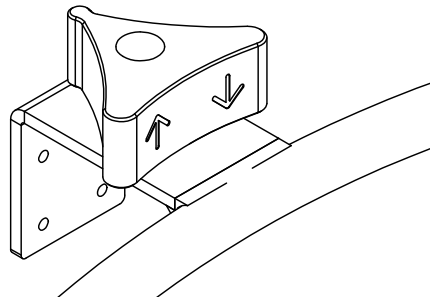

## Rear Wheel Locks

The rear wheels must be locked before lifting, lowering, or using as a workstation. Just press with foot to lock and press with foot to release.



UNLOCKED

LOCKED

## 5.1 Safety Areas and Distance



### Safety when operating the tool

The operator must ensure that the tool is clear of obstacles before lifting, lowering or rotating. The operator must warn other personnel before lifting, lowering or using the tool.

When lifting or lowering the tool, the operator must:

- stand behind the wheels of the lifter as illustrated below (● A).
- ensure that all other personnel are out of the danger zone as illustrated below (● B).

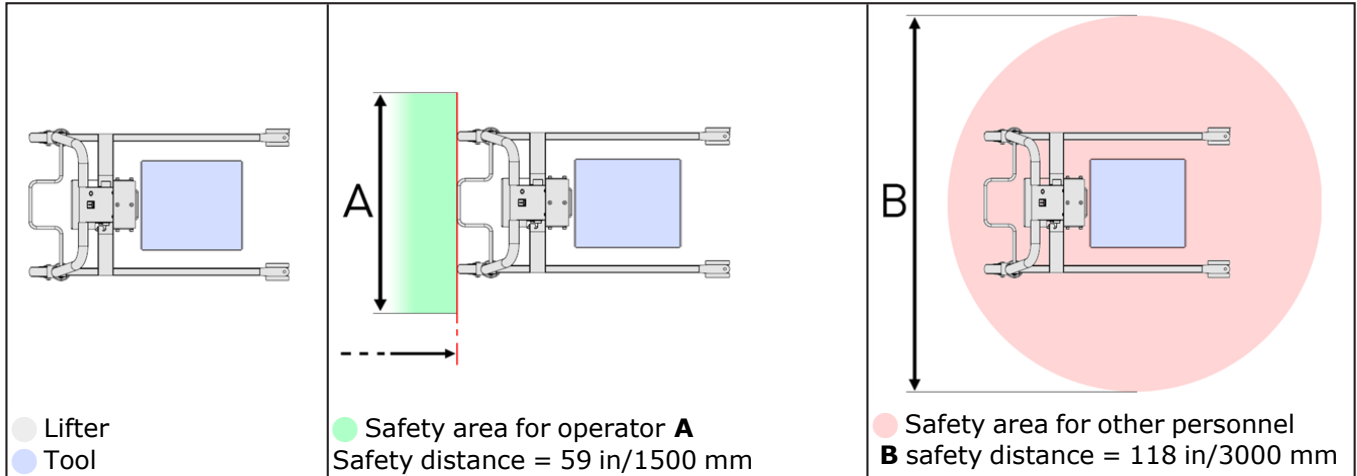

## 5.2 Batteries, Connectors, and Chargers

The two 12v batteries included with this lifter are wired in series to provide a 24v DC circuit.

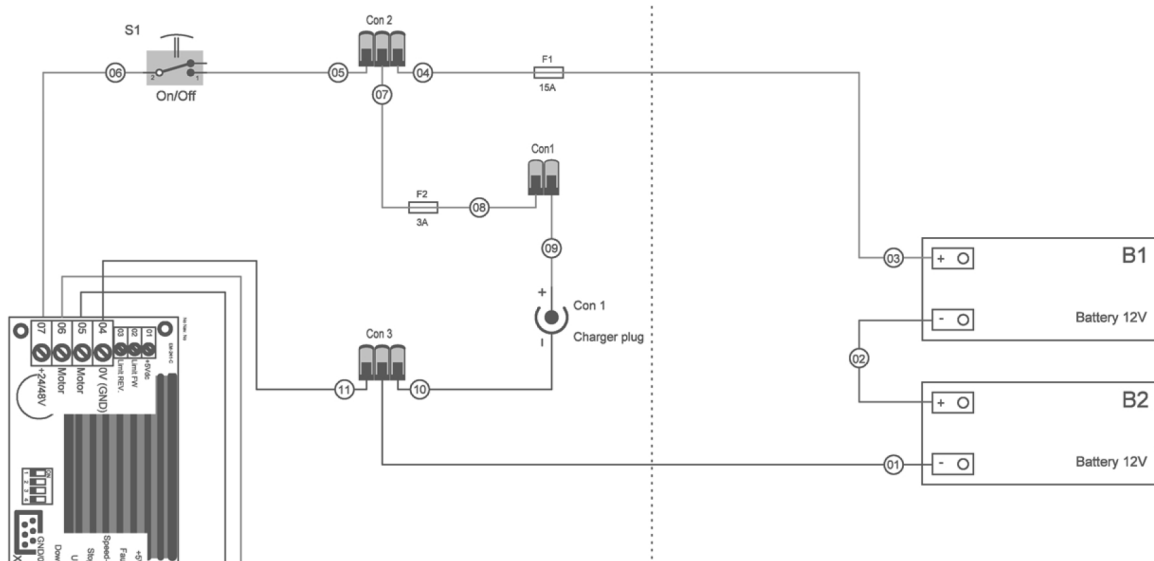

If replacement is needed, see below. Note the position of the batteries and the cables. Replace both batteries at the same time. Use Torx20 driver to remove cover screws.



The batteries are charged using an external AC/DC charger. They should be charged daily, as total discharge can damage the batteries or shorten their life. Runtime per charge will vary based on the loads raised and the frequency of use. When batteries are fully charged, turn OFF the lifter when not in use. (Pushbutton out for OFF.)

Our typical charger is shown on the next page and includes a grounded (3-prong) AC plug that plugs into a typical 115v 60 hz wall receptacle. The other end includes a 2.1mm ID with 2.1 mm to 2.5mm ID adapter connector that plugs into the mast DC input receptacle. The 2.1 mm ID connector allows charging our older models shipped before February 2023 and the 2.5 mm ID connector allows charging our newer models sold after January 2023.



**NOTICE**

The 2.5 mm ID connector will still physically fit into the older model 2.1 mm pin OD mast receptacles, however the electrical connection will not be stable enough to sustain a charging voltage/current to successfully charge the batteries. See information below for discerning the difference between these two versions of mast receptacles.



2.1mm

2.5mm

The images to the left above and below show an older model mast with black plastic round receptacle (2.1mm). The images to the right above and below show a newer model mast with metal round receptacle (2.5mm).



2.1 mm



2.5 mm

## **NOTICE**

••• **The Lifter on/off switch should be off when charging the batteries. Pushbutton out for OFF.**

The charger automatically charges the batteries until the batteries are fully charged. At that time, the LED charger indicator will change from orange to green. The batteries are fully charged after approximately 5 hours.

### **LED Charger Indicator**

- Orange: The charger is connected to main power and charging.
- Green: DC connector open or float charging and ready for use. Ensure the DC connector to the mast is fully engaged when first inserting it. Plugging in the charger into a 115v AC outlet without connecting the DC connector to anything will also illuminate the green LED.

## **⚠ CAUTION**

**Safety when charging - Use only the original charger. Check that the wires are in good condition and connected properly before applying power. Make sure there is no dirt or water in/on the DC connector or the AC plug.**

**Do not operate the lifter while charging.**



## 6 APPLICATION TOOL

### 6.1 Platform and Frame (HDPE Plastic)

The capacity of this machine is 150 lbs. uniformly loaded with a 9.5" load center.

The platform can be used to handle various items or boxes.

Use the lifter to level the platform with the object to be lifted. The object can with little effort be pulled onto the platform. The same method is used to get the object off the platform again.



#### **Safety when using the Platform**

Boxes handled with the platform must not be substantially larger than the platform, as there is risk of dropping the item.



Platform

## 7 MAINTENANCE AND INSPECTION

All Presto Lifts products are designed for minimum maintenance, however some safety checks and maintenance are required.

### **DANGER**

**High Voltage:** Electrical service must be performed by trained and/ or qualified personnel. Disconnect the charger before repairing the Lifter. The charger is equipped with an AC electric cord having an equipment-grounding conductor and ground plug. Never alter this cord/plug. It must be inserted into a properly installed/ specified outlet in accordance with all local codes and ordinances.

DC motors and AC chargers can create sparks. Do not set up this machine in an area where flammable gases may be present.

All electrical components must be protected from wet and/or dirty environments unless specifically configured for such environments.

Pinch points and Crush Hazards exist when moving and transporting the machine. Do not enter under any equipment while moving or transporting. Keep hands, feet, and loose clothing away from moving equipment.

Pressurized fluids can penetrate skin and cause severe injury or death. Always use proper personal protective equipment when working with pressurized systems.

Never enter beneath the platform unless the machine is unloaded and secured against lowering.

No personnel are permitted on the platform. Do not sit, stand, or ride.

Loads that may shift during operating must be secured before operating.

Keep hands, feet, and loose clothing away from moving parts.

Turn off the Lifter, disconnect the charger and disconnect the battery circuit before performing any electrical component or cam belt repair or replacement to avoid injury. When disconnecting the batteries, remove the negative lead first (Wire 01), then the positive lead (Wire 03). Reconnect by connecting the positive lead first (Wire 03), then the negative lead (Wire 01). See electrical schematic.

## **CAUTION**

**Always use appropriate Personal Protective Equipment when performing maintenance or repair.**

**Do not load or unload the machine while moving.**

**Engage rear wheel locks before lifting, lowering, or using as a workstation.**

**When transporting a load, it shall be lowered to the lowest possible position and secured to ensure the load cannot slide.**

**This machine does not have safety toe guard protection.**

**The load's center of gravity must be maintained within the area indicated in the Loading section. Uneven or off-center loading may cause excessive wear or permanent damage or the load could fall and cause injury.**

### **7.1 Daily Checks**

Presto Lifts strongly recommends the following checks to be carried out on a daily basis and before using the lift. Ensure that the lift is functioning as intended. If in doubt, do not use.

- The lifter must be free of dirt or debris which could affect safe operation
- Ensure all labels are present, without damage and are readable
- Ensure no signs of wear, unusual sounds or visual defects
- Ensure bolts, nuts and rivets are not loose
- Ensure correct operation of the rear wheel locks
- Ensure the lifter moves freely on its wheels and casters (when rear wheel locks are released)
- Ensure control unit is in working order

## 7.2 Semi-Annual Checks

Maintenance on critical components must be performed by a qualified technician.

### 7.2.1. Critical Components

The critical components listed below must be replaced within the intervals stated to ensure that the lifter is in safe, operational condition. Please contact Presto Lifts for instructions on how to replace critical components as necessary.

**Cam Belt** - Replace when/if any of the observations below occur (see Cam Belt and Sprocket Replacement section):

- Any sign of wear, visual cracks, or miscolor
- Under normal use (use < 20 lifts per day average over a year), replace after 8 years
- Under intensive use (use > 20 lifts per day average over a year), replace after 4 years

**One Way Bearing** - Replace when/if any of the observations below occur (see Cam Belt and Sprocket Replacement section):

- Any sign of wear, unusual sounds or visual defects
- Under normal use (use < 20 lifts per day average over a year), replace after 8 years
- Under intensive use (use > 20 lifts per day average over a year), replace after 4 years

### 7.3 Cam Belt Adjustment

The cam belt moves the sledge on which the platform is mounted. The cam belt should be regularly inspected (semi-annually) for wear and tear. The steel reinforcement of the cam belt secures against breakage but wear and tear of the plastic parts may cause unstable lifting or crackling noises.

Unbolt the six bolts securing the platform to the sledge.



Remove the front plate, the screws are M4x8 Torx 20.



The belt should have a springy feeling and should only deflect approximately 10 mm under moderate thumb pressure. If the belt deflects more, tighten. The belt may also be checked using a belt tension tester as illustrated below.



Locate the two screws on top of the mast. To tighten the toothed cam belt, turn the two screws clockwise with a 4 mm hex key. Tighten the screws the same amount and check the tension of the toothed cam belt for every time the screws are tightened a quarter turn.

In the case where the cam belt is not properly aligned (when viewing the belt position on the belt tension idler pulley ( top of mast) ), tighten the screw in the side the cam belt is drifting towards. Tighten one quarter turn at a time and run the sledge up and down intermediately to check alignment. Keep adjusting to desired result.



The belt tension for the PLS53-150 should measure 29 hz on a belt tension tester. Add front cover and run the final lifting test.



## 7.4 Cam Belt and Sprocket Replacement

This section exposes various parts inside the mast including the belt tension idler pulley (top of mast), the toothed cam belt, the sledge, the cam belt sprocket with one-way bearing (bottom of mast) and switches.

Unbolt the six bolts securing the platform to the sledge.



Lay the Lifter down on a table.

Remove the cover plate.



Parts within the top of the mast include the up/down function switches and the top limit switch.

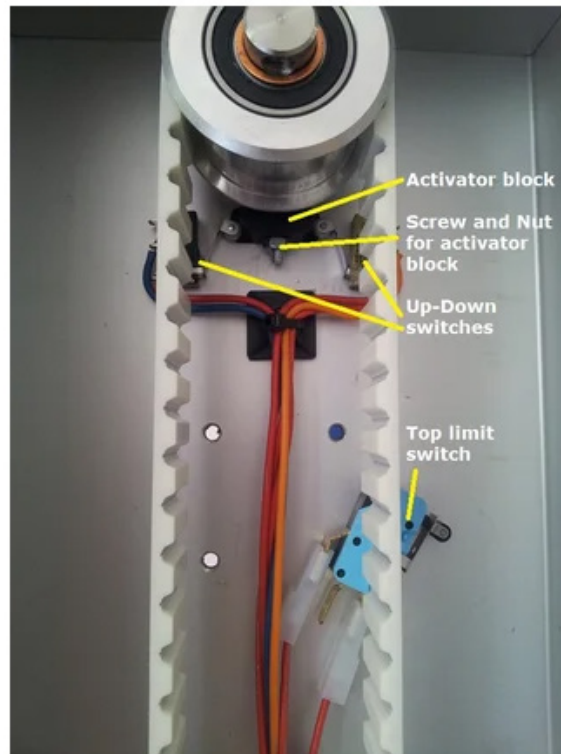

Locate the 2 screws in the top of mast and release tension on the cam belt. If you are replacing the cam belt, you can remove the screw on the open end of the belt tension idler pulley (top of mast) that the belt will be removed from.





Remove the screws of the cam belt sprocket bracket (bottom of mast).



Lift it up gently and slide the bracket off. If it is stuck, you might use tools gently to get it free.

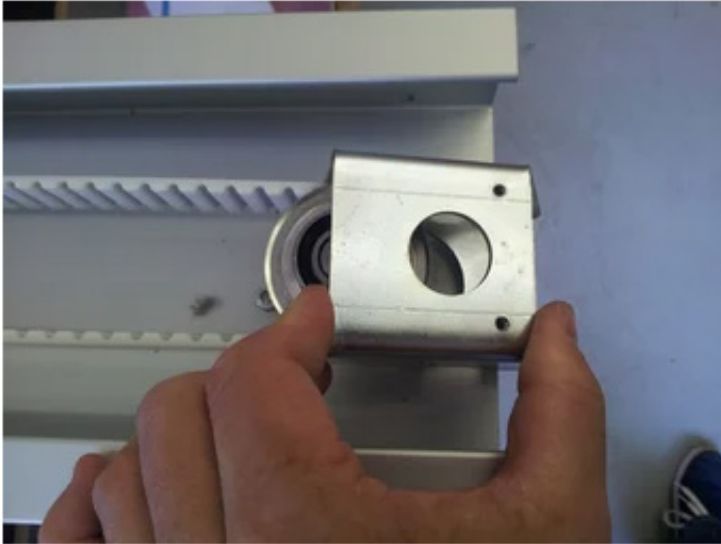

Take away the top bearing (it should come off rather easily) and lift up the cam belt sprocket with the cam belt. Note the orientation of all components removed for reinstallation purposes. Also note the arrow direction of the cam belt sprocket with one-way bearing as well as the orientation of the two different sized spacers.

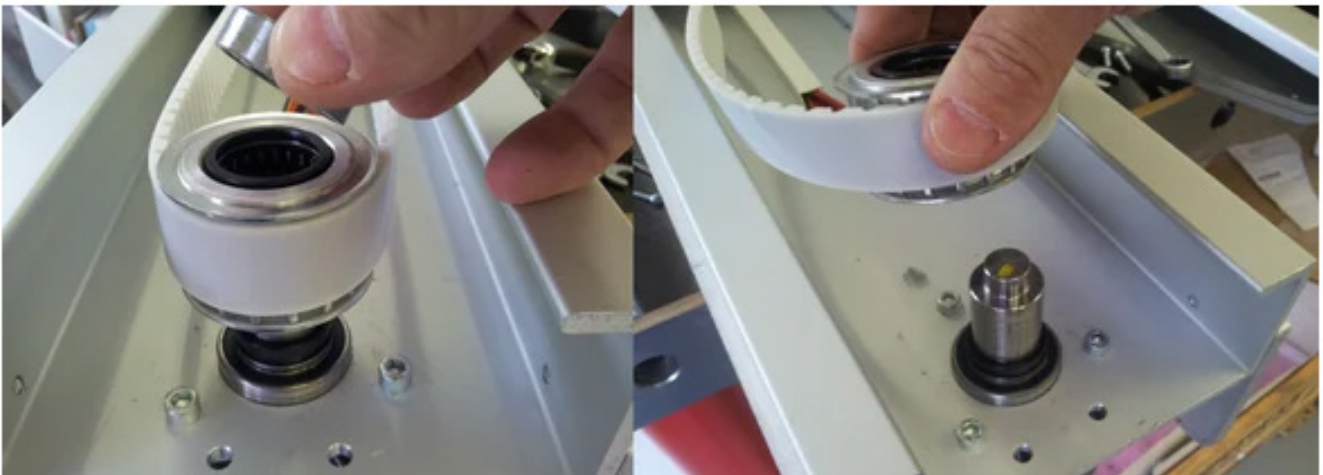

Slide off the sledge with cam belt from the bottom of the mast and remove the screws holding the cam belt. When reinserting the new cam belt, make sure that 4 teeth in each end are held in place by the fastening plate on the sledge.

Once the replacement cam belt has been fastened to the sledge, reinstall both back into the bottom of the mast the same way as it was removed.

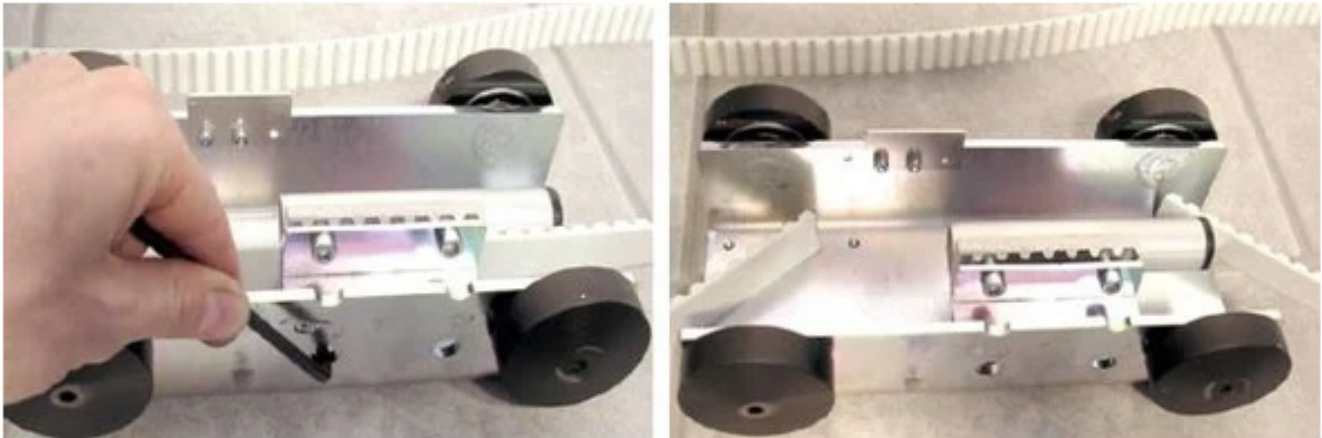

Insert the new cam belt spocket with one-way bearing. Orient it and the two different thickness spacers in the same order and direction as was previously removed.



Ensure the cam belt sprocket is in the right position before adding the top bearing.

Loop the cam belt over the cam belt sprocket.

Reinstall the cam belt sprocket bracket and tighten the screws securing the bracket.



Secure the cam belt over the belt tension idler pulley at the top of the mast and reinstall the screw back through the top of the mast into the pulley shaft that was previously removed to in order to remove the belt. Adjust both screws so that the end of each screw is flush with the pulley shaft. Then turn each screw clockwise a full turn alternately while aligning the belt tension idler pulley to 90° using a try square.

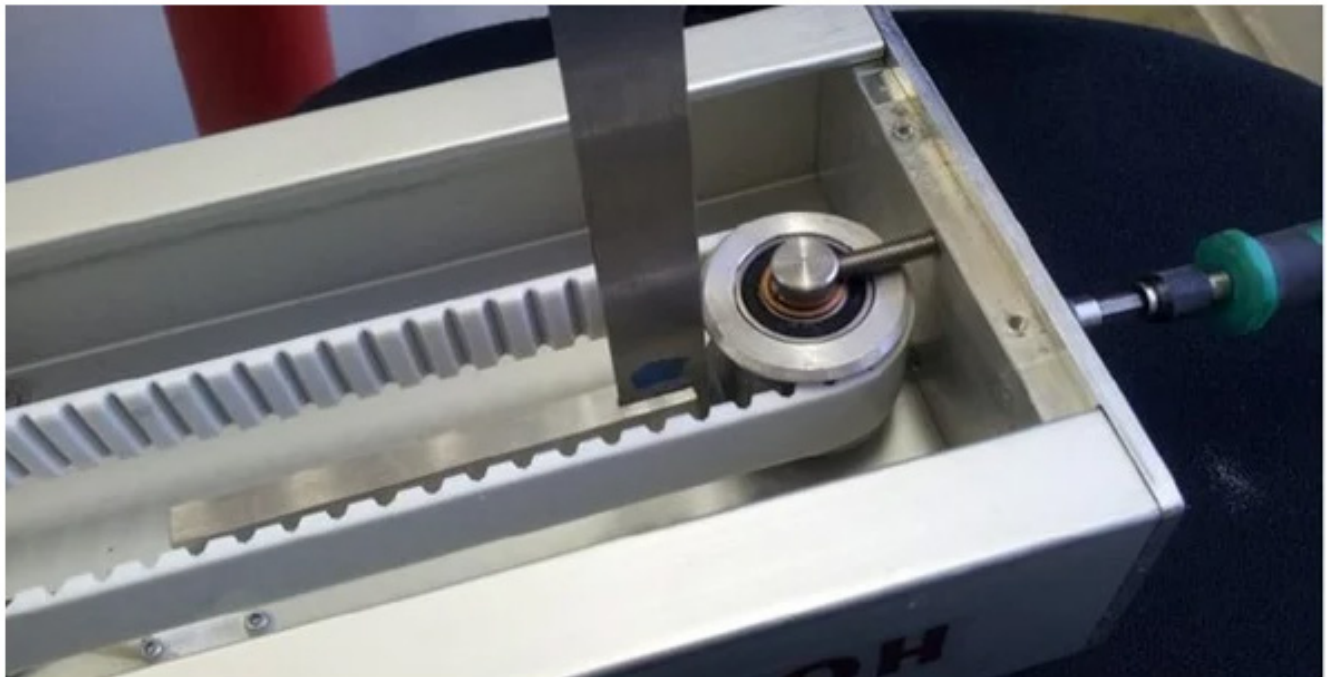



To tighten the cam belt, turn the two screws clockwise with a 4 mm hex key. Tighten the screws the same amount and check the tension of the cam belt. The belt tension for the PLS53-150 should measure 29 hz using a belt tension tester.

When the tension is right and the belt tension idler pulley is aligned, you can raise the Lifter up and reinstall the platform. Test the lifter a couple of times with load and check the cam belt tension and cam belt position in the belt tension idler pulley.

In the case where the cam belt is not properly aligned, tighten the screw on the side the cam belt is drifting towards. Tighten one quarter turn at a time and run the sledge up and down intermediately without load to check alignment.



Measure the cam belt tension again with a belt tension tester.



Once the tension has been confirmed to be at 29 hz, reinstall the front cover and run the final lifting test.

After several hours of use once the belt has fully had a chance to break in, measure the cam belt tension again with a belt tension tester. Readjust as needed.



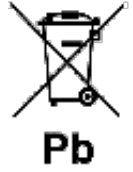

## 7.5 Disposal

When disposing the lifter, make sure to sort the different materials by category, metal, electronic waste, batteries etc.. Make sure to follow the local environmental legislations, and hand over the materials to the local recycling station.



- Note: The batteries contain lead and must be disposed accordingly!

## 8 CLEANING INSTRUCTIONS

<b>Ingress protection marking (IP)</b>			
<b>Model-approved IP code:</b>	<b>IP 41</b>	<b>IP code description</b>	
Solid particle protection	IP 4X	>1 mm	Most wires, slender screws, large ants etc.
Liquid ingress protection (with batteries)	IP X1	Dripping water	Dripping water (vertically falling drops) shall have no harmful effect on the specimen when mounted in an upright position onto a turntable and rotated at 1 RPM.
<b>Special instructions/Precautions</b>			
<ul style="list-style-type: none"> <li>• Always wear the correct safety equipment</li> <li>• Lower the lifting tool, so that you don't risk a head injury when cleaning near the floor.</li> <li>• The battery charger must be disconnected from the main during cleaning.</li> <li>• In case of remote control the plug on the mast must be protected during cleaning.</li> </ul>			
<b>Detergent application</b>			
	<ul style="list-style-type: none"> <li>• Use a standard PH neutral cleaning detergent.</li> </ul>		<ul style="list-style-type: none"> <li>• Do not use Acid, Alkaline or harsh chemical products, these might weaken the drive belt and other sensitive components or leave marks on the surfaces.</li> </ul>
<b>Work process</b>			
	<ul style="list-style-type: none"> <li>• The outer surfaces can be cleaned using a wet brush or a damp cloth.</li> </ul>		<ul style="list-style-type: none"> <li>• Do not use liquids to clean the lifter as this may have adverse effect on the electrical components.</li> </ul>
<b>Key inspection points</b>			
	<ul style="list-style-type: none"> <li>• Test that all functions are working properly before the lifter is placed back into service.</li> </ul>		

## 9 RESOLVING FAULTS

Fault Type	Check the following	Solve
The timing belt jumps on the belt wheel (the belt is making crackling noises)	Is the belt slack?	Tighten the belt using the screws at the top of the mast.
	Is the belt worn?	Replace the belt.
The belt is skewed (the belt squeaks)	Is the belt running skewed in the track on the belt tension idler pulley at the top of the mast?	Adjust the screw at the top of the mast on the side to which the belt is skewed.
	Is the belt worn?	Replace the belt.
The sledge jerks	Is there dirt in the mast on which the sledge runs?	Remove the dirt and wipe with alcohol.
	Is there dirt on the sledge wheels?	Remove the dirt or replace the wheels.
The lifter does not respond	Check whether the item being lifted is heavier than the lift's capacity.	Remove the item.
	Check the main fuse or the on/off button.	Replace the main fuse or press the button.
	Check that the batteries are charged.	Connect the charger.
The lift works very slowly	Check the voltage of the batteries.	Connect the charger.
	Check the charging frequency. Does the light quickly change to green when connected?	If the charger quickly changes to green, it could indicate that the batteries should be replaced or that the fuse on the charger is broken or the main switch is off.

# 10 ELECTRICAL SCHEMATIC - SOFTSTART

Revision	Date	Drawn by	Approved By	Description
R1	2021/01/29	KOF	SR	Initial drawing

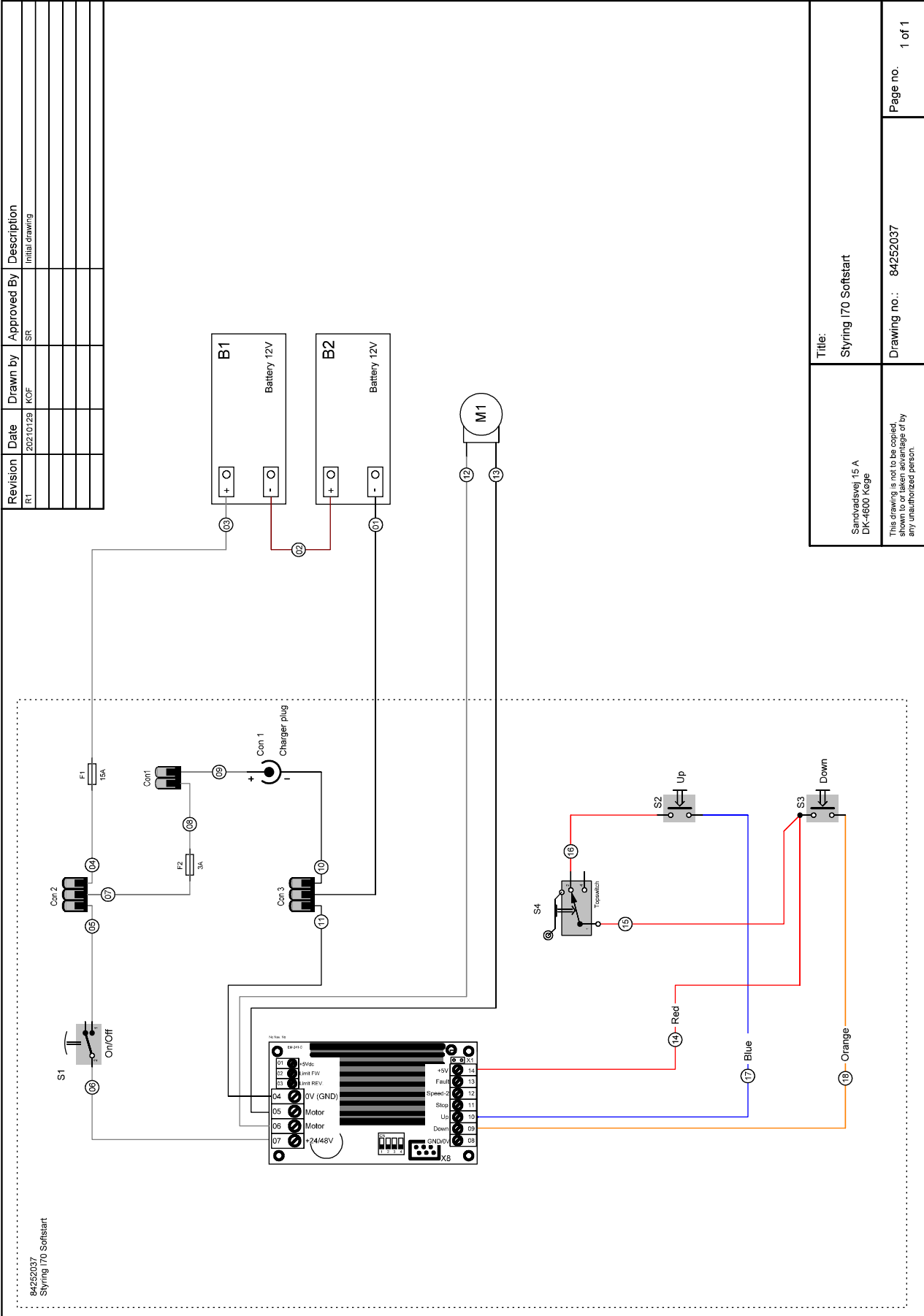

84252037  
Styring I70 Softstart

Samfundet 15 A DK-1600 Koge	Title: Styring I70 Softstart	Page no. 1 of 1
This drawing is not to be copied, blown to or taken advantage of by any unauthorized person.	Drawing no.: 84252037	



# 11 SPARE PARTS

## 11.1 Mast Complete

ITEM NO.	PART NUMBER	DESCRIPTION	Default/QTY.	Revision
1	40010759	Mast WP 70L	1	1
2	30007662	Handle WP 70 gray	1	3
3	81030005	Washer M5 FZB DIN 125 A	4	1
4	81010329	Tapfite M5x1 6 FZB	4	1
5	84020042	Charger 230-24V 1.8A	1	1

PARTS: MANUFACTURER PART NO. PARTS LIST PART NO. DRAWING PART NO.	CODE: CODE	ORDERING INFORMATION: ORDERING INFORMATION	REVISION: REVISION: 1
TITLE: Mast WP 70L Komplet		IMPACT: Impact 70	
MATERIAL: ALU/Steel		PART NO.: 40010774	
WEIGHT (G): 22,24g		DRAWING NO.: 40010774	
		SHEET NO.: 1/10	

# 11.2 Mast

REVISIONS		APPROVED		DATE		DESCRIPTION	
ZONE	REV.						
-	-	-	-	-	-	-	See Sheet1

ITEM NO.	PART NUMBER	DESCRIPTION	QTY.
1	40004346	Søjle Impact 70L	1
2	40000665	Top plate Impact Mast	1
3	40000719	Afstandsplade motor-mast Impact 80	1
4	85020022	Motor 18V shaft shortened to L-16mm	1
5	30000478	Lejebeslag Motoraksel	1
6	40000729	Motoraksel Impact 80	1
7	40000720	Lejebøsning aksel Impact 80	1
8	40000143	Timing Belt Pulley AT10/16 - Complete	1
9	40000699	Spacer for motor shaft Impact 130	1
10	40000730	Afstandsring Remijul Impact 80	1
11	40001894	Topwheel complete Impact 70-80-130	1
12	81030086	Spacer for topwheel	2
13	4002889	Batteril 12V 7.2AH	2
14	40002819	Støbe Impact 70 komplet	1
15	40002887	Tandrem AT10-25x29-34	1
16	40002880	Dæklade Impact 70L	1
17	4002860	Glider H-Commander	1
18	40002866	Batteribeslag	1
19	84130020	Cable channel 1x12 white 130mm.	1
20	84130020	Cable channel 1x12 white 200mm.	1
21	84130020	Cable channel 1x12 white 520mm.	1
22	40004017	Sideplade for WP - grø	2
23	4002872	Dækskærm	2
24	40002707	Feder dækskærm	1
25	84252037	Slyng 170 Softstart	1
26	81010265	Screw M6x14 BH FZB ISO 7980	4
27	40002840	Tapflite 4x20 FZB DIN 7500	12
28	81010328	Tapflite 4x8 FZB DIN 7500	8
29	81010314	Screw M4x16 CH FZB DIN 912	1
30	81010119	Screw M6x20 CH FZB DIN 912	3
31	81190092	Ball bearing DIN 625 - 6905 2RS	1
32	81190090	Leje 6002 2RS	1
33	81010105	Screw M6x55 CS FZB DIN 7991	2
34	81020004	NUT M6 FZB DIN 934	2
35	81010118	Screw M6x16 CH FZB DIN 912	2
36	81020020	Lock nut M4 FZB DIN 985	1
37	81010426	Screw M3x14 CH FZB DIN 912	2
38	M2x12 RH ISO 1580		4
39	40004010	Gummidut SJ5003 - M3 Bumpen	7
40	40002234	Socket for cable tie 19x19	2

UNLESS OTHERWISE SPECIFIED, DIMENSIONS AND WEIGHTS ARE IN METRIC UNITS.

DO NOT SCALE DRAWING

IMPACT 70L

Impact 70

40010759

Material: All/Steel

Revision: 2

DATE: 10/11/14

BY: [Signature]

DATE: 10/11/14

BY: [Signature]

# 11.3 Handle

REVISION	NAME	LOCATION	DATE	TITLE
2				
3				
4				
5				
6				
7				
8				
9				

ITEM NO.	PART NUMBER	DESCRIPTION	Default/QTY.	Revision
1	30007681	Håndtag WP 70 gray svejst	1	2
2	30007481	Aksel for Commander 2015	1	1
3	30007480	Commander 2015	1	2
4	81140027	End plug $\varnothing 25 \times 1 - 2.5$ indiv.	2	3
5	81030066	Rip-Lock $\varnothing 10$ A2	1	1
6	81010285	Skruer 10x20 RH A2 ISO 7380	1	1
7	81010257	Skruer 5x10 RH A2 ISO 7380	1	1
8	81130004	Round end cap $\varnothing 15/20 \times 4$ black	1	1

FINISH: DEBUR AND REMOVE SHARP EDGES		DO NOT SCALE DRAWING	Version: 3
UNLESS OTHERWISE SPECIFIED, DIMENSIONS ARE IN MILLIMETERS AND WITH TOLERANCES AFTER ISO 2768-1 MODEL			
MATERIAL: Steel		WEIGHT: 1.13 kg	
DWG NO. 30007682		DRAWN BY: m DATE: 15.02.07	
A3		SHEET 1 OF 1	

**Handle WP 70 gray**

# 11.4 Standard Legs - Angled

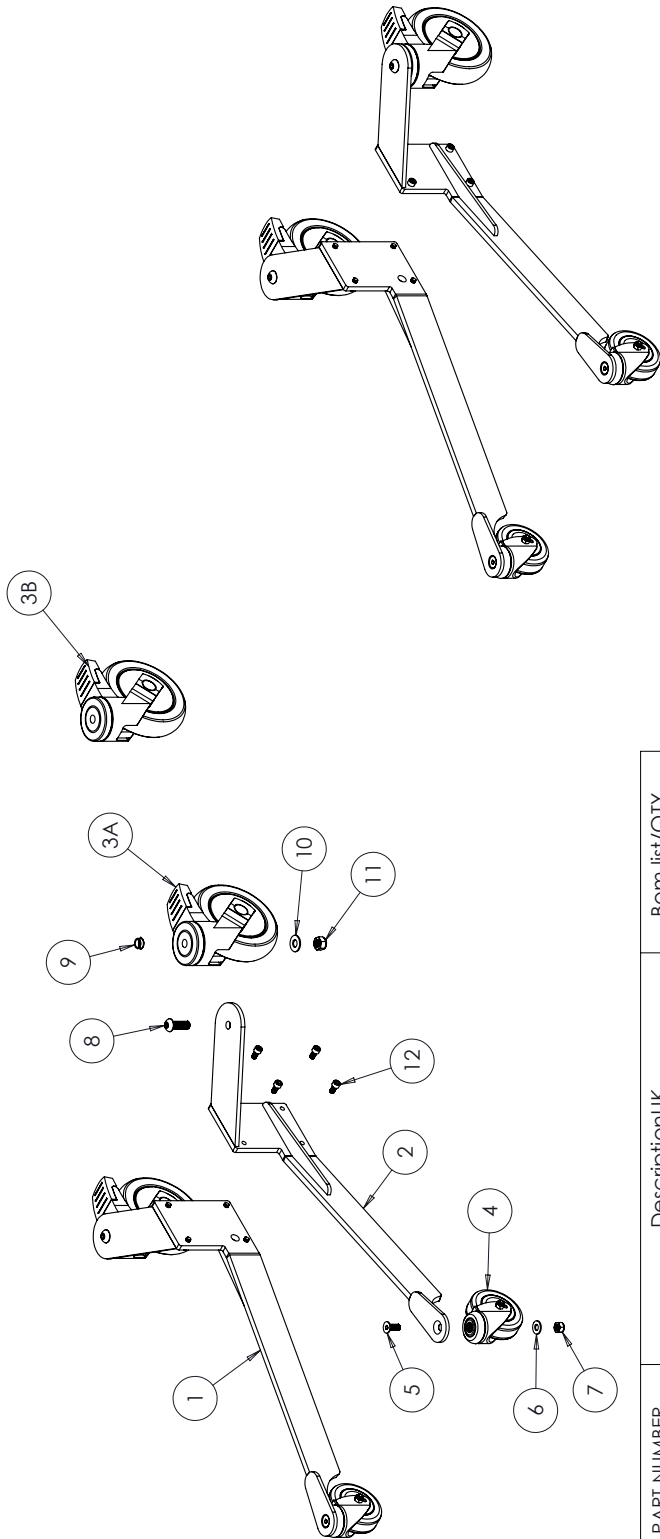

ITEM NO.	PART NUMBER	DescriptionUK	Bom list/QTY.
1	30007339	Legset right FP angled - welded	1
2	30007340	Legset left FP angled - welded	1
3A	81200044	Wheel ø125 w/brake	2
3B	81200051	Wheel ø125 w/brake ESD	2
4	81200043	Wheel ø75 - bh90	2
5	81010089	Screw DIN 7991 - M8 x 20	2
6	81030102	Rip-Lock washer ø8	2
7	81020024	Lock nut M8 A2	2
8	81010462	Screw ISO 7380 - M10 x 20	2
9	40002208	Plast bushing ø10/12x8	2
10	81030103	Rip-Lock ø10-2	2
11	81020025	Locknut DIN 986 - M10	2
12	81010435	Screw DIN 985 M6x12 CH	8

FINISH: UNLESS OTHERWISE SPECIFIED, ALL SURFACES SHALL BE FINISHED AND WITH TOLERANCES AFTER DIN ISO 2768-1 M/DL		DEBUR AND REMOVE ALL SHARP EDGES		DO NOT SCALE DRAWING		Version: 2	
REVISION	NAME	LOCATION	DATE	TITLE: <b>Legtype 70 Angled</b>			
				Impact			
MATERIAL: Steel			DWG NO. 40010275	A3 1/10			

## 12 ANNUAL INSPECTION

**Date of inspection:**

**Controller:**

**Comments:**

_____	_____	_____
_____	_____	_____
_____	_____	_____
_____	_____	_____
_____	_____	_____
_____	_____	_____
_____	_____	_____
_____	_____	_____
_____	_____	_____
_____	_____	_____

## 13 WARRANTY & CONTACT INFORMATION

Presto Lifts warrants this product to be free from defects in material or workmanship for the duration of the warranty period. Warranty periods vary and begin on the date of shipment. For specific warranty information, contact Presto Lifts with the machine's serial number.

Any claim for breach of this warranty must be received in writing by Presto Lifts within the warranty period. Warranties shall not cover failure or defective operation, caused by misuse, misapplication, negligence or accident, exceeding recommended capacities, or any alteration or repair of the item purchased which has not been authorized by Presto Lifts. Except as set forth herein, Presto Lifts makes no other warranties, express or implied, including THE WARRANTIES OF MERCHANTABILITY AND OF FITNESS FOR A PARTICULAR PURPOSE, all of which ARE HEREBY EXCLUDED.

Presto Lifts meets the labeling requirements of California's Proposition 65. Presto Lifts makes no warranty or representation with respect to the compliance of any product with other State or local safety or product standard codes and any failure to comply with such codes shall not be considered a defect of material or workmanship under this warranty. Presto Lifts shall not be liable for any direct or consequential damages arising out of such non-compliance.

Presto Lifts' obligations under any warranty or for any other damages which may arise under any sale, agreement, or contract, are limited to the replacement or repair of defective components at its factory or another location at Presto Lifts' discretion. This is buyer's sole remedy under any such warranty, sale, agreement, or contract. Presto Lifts will not be liable for consequential, incidental, exemplary, or punitive damages of any kind resulting from a breach of any warranty that it has provided or for breach of any term of any sale, agreement, or contract. Any warranty may be altered only in writing by Presto Lifts.

All commodities, software, or technology purchased from Presto Lifts are subject to the export and re-export control laws and regulations of the United States, including but not limited to the Export Administration Regulations ("EAR") and Department of the Treasury Office of Foreign Asset Controls ("OFAC") Regulations. Presto Lifts expects all distributors and customers to comply with these laws and regulations. Without limiting the foregoing, the distributor/customer cannot, without proper authorization from the applicable United States Government Agency, export, re-export, or transfer any commodity, software, or technology purchased from Presto Lifts, either directly or indirectly, to any entity, country, or national of any country in breach of such laws and regulations. Furthermore, Presto Lifts expects that the distributor/customer shall indemnify and hold harmless Presto Lifts from and against any claim, proceeding, action, fine, loss, cost and damages arising out of or relating to any noncompliance with export control regulations by distributor/customer, and distributor/customer are expected to compensate Presto Lifts for all losses and expenses resulting thereof, unless such noncompliance was clearly not caused by fault of the distributor/customer.

Presto Lifts Inc., 2 Hampshire Street, Suite 102, Foxborough, MA 02035  
800.343.9322 | Fax: 888.788.6496  
service@prestolifts.com  
www.PrestoLifts.com



To view a copy of the Terms and Conditions of Sale, go to: <https://PrestoLifts.com>  
(Find in About Us pull down menu)