

# **Presto** LIFTS **ECO A**

## P3 All-Around Air Owner's Manual



Model: P3 All-Around Air  
Serial Number: \_\_\_\_\_  
Date placed in service: \_\_\_\_\_

Presto Lifts Inc.  
50 Commerce Way, Norton, MA 02766  
Phone: 800.343.9322  
Fax: 888.788.6496  
www.PrestoLifts.com  
Email: [service@prestolifts.com](mailto:service@prestolifts.com)

# Contents

<b>1</b>	<b>Introduction.....</b>	<b>4</b>
1.1	Specifications.....	4
1.2	Responsibilities of Owner and Users.....	4
1.3	Responsibilities of Operators.....	5
<b>2</b>	<b>Safety.....</b>	<b>7</b>
2.1	Safety Alert Symbols .....	7
2.2	Signal Words .....	7
<b>3</b>	<b>Labeling.....</b>	<b>8</b>
3.1	Label Part Numbers & Quantity.....	8
3.2	Label Location Diagram .....	8
<b>4</b>	<b>Setup.....</b>	<b>9</b>
4.1	Component Identification.....	9
4.2	Machine Setup.....	10
<b>5</b>	<b>Operation.....</b>	<b>11</b>
5.1	Manual Loading & Unloading.....	11
5.2	Fork Truck or Stacker Loading & unloading .....	12
5.3	Transporting .....	12
5.3.1	Transporting with Fork Trucks and Stackers.....	12
5.3.2	Transporting with Portability Kits .....	12
<b>6</b>	<b>Maintenance &amp; Repair .....</b>	<b>14</b>
6.1	Maintenance Pins.....	14
6.2	Periodic Maintenance .....	15
6.2.1	Weekly .....	15
6.2.2	Every Six Months.....	15
6.3	Ordering Replacement Parts.....	16
<b>7</b>	<b>Troubleshooting .....</b>	<b>17</b>
<b>8</b>	<b>Warranty &amp; Contact Information .....</b>	<b>18</b>

 <b>WARNING</b>
Cancer and Reproductive Harm - <a href="http://www.P65Warnings.ca.gov">www.P65Warnings.ca.gov</a>

This label (part # 10095524) is required by California Law. For more information visit:

[www.P65Warnings.ca.gov](http://www.P65Warnings.ca.gov)

# 1. Introduction

## 1.1 Specifications

Load Capacity	400 to 4500 lb. / 180 to 2040 kg.
Load Dimensions	50" x 50" x 72" / 1270 mm x 1270 mm x 1800 mm
Base Frame	36" x 36" / 915 mm x 915 mm
Compressed Height	9 1/2" / 240 mm
Extended Height	27 3/4" / 705 mm
Air Source	80 PSI / 5.5 BAR
Maximum System Pressure (Unloaded)	30 PSI / 2.1 BAR
Maximum System Pressure (Loaded)	65 PSI / 4.5 BAR
Safety Relief Valve Setting	125 PSI / 8.6 BAR
Rotating Ring, Outer Diameter	43 5/8" / 1110 mm
Rotating Ring Inner Diameter	40 5/8" / 1030 mm
Shipping Weight	450 lb. / 205 kg. (Approximately)
Operating Environment	Indoor Only
Operating Temperature	0°F to 120°F / -18°C to 50°C

## 1.2 Responsibilities of Owner and Users

**Basic Principles** - Owners/users shall apply sound principles of safety, training, inspection, maintenance, and expected operating environment. It shall be the responsibility of the owner/user to advise the manufacturer where deflection may be critical to the application.

**Manuals** - Owners/users shall keep and maintain a copy of the operating and maintenance manual(s) and ensure its availability to operating and maintenance personnel.

**Inspection and Maintenance** - It shall be the responsibility of the users to inspect and maintain the machine as required to ensure proper operation. The frequency of inspection and maintenance shall be based upon the manufacturer's recommendations and be compatible with operating conditions and the severity of the operating environment. Machinery that is not in proper operating condition shall be immediately removed from service until repaired. Maintenance and repairs shall be made by a qualified person and the repairs shall be in conformance with the manufacturer's recommendations.

**Maintenance Safety Precautions** - Before adjustments and repairs are started on the machine, the following precautions shall be taken as applicable:

1. Remove the load from the machine.
2. Other precautions and directions as specified by the manufacturer.

**Replacement Parts** - When parts or components are replaced, they shall be replaced with parts or components approved by the original manufacturer.

**Maintenance Training** - The user shall ensure only qualified personnel inspect and maintain the machine in accordance with the manufacturers recommendations.

**Operator Training** - An owner/user, who directs or authorizes an individual to operate the machine shall ensure that the individual has been:

1. Trained in accordance with the manufacturer's operating manual.
2. Made aware of the responsibilities of operators as outlined in this manual.
3. Retrained, if necessary, based on the owners/user's observation and evaluation of the operator.

**Modifications** and additions shall not be performed without the manufacturer's prior written approval. Where such authorization is granted, capacity, operation, and maintenance instruction plates, tags, or decals shall be changed accordingly.

### 1.3 Responsibilities of Operators

**Basic Principles** - Operators shall apply sound principles of safety and good judgment in the application and operation of the machine with consideration given to its intended use and expected operating environment. Since the operator is in direct control of the machine, conformance with good safety practices is the responsibility of the operator. The operator shall make decisions on the use and operation with due consideration for the fact that his or her own safety as well as the safety of other personnel on or near the machine is dependent on those decisions.

**General Training** - Only personnel who have received general instructions regarding the inspection, application and operation of the machine, including recognition and avoidance of hazards associated with the operation, shall operate the machine. Such topics covered shall include, but not necessarily be limited to, the following issues and requirements:

1. A pre-use inspection
2. Responsibilities associated with problems or malfunctions affecting the operation of the machine.
3. Factors affecting stability
4. The purpose of placards and decals
5. Workplace inspection
6. Safety rules and regulations
7. Authorization to operate
8. Operator warnings and instructions
9. Actual operation of the machine. Under the direction of a qualified person, the trainee shall operate the machine for a sufficient period of time to demonstrate proficiency in actual operation of the machine.

**Pre-start Inspection** - Before use each day or at the beginning of each shift, the machine shall be given a visual inspection and functional test including but not limited to the following:

1. Pneumatic system leaks
2. Loose or missing parts
3. Nameplates, precautionary and instructional markings and/or labeling.
4. Items specified by the manufacturer.

**Problem or Malfunctions** - Any problems or malfunctions that affect the safety of operations shall be repaired prior to the use of the machine.

**Before Operations** - The operator shall:

1. Read and understand the manufacturer's operating instruction(s) and user's safety rules or have them explained.
2. Understand all labels, warnings, and instructions displayed on the machine or have them explained.

**Workplace Inspections** - Before the machine is used and during use, the operator shall check the area in which the machine is to be used for possible hazards such as, but not limited to:

1. Bumps, floor obstructions and uneven surfaces
2. Presence of unauthorized persons
3. Other possible unsafe conditions as noted in the operating manual.

**Operator Warnings and Instructions** - The operator shall ensure the operation of the machine is in compliance with the following:

- **Distribution of load** - The load and its distribution on the platform shall be in accordance with the manufacturer's rated capacity for that specific configuration.
- **Point of Operation** - The operator shall not place any part of their body under the platform.
- **Precaution for moving equipment** - When other moving equipment or vehicles are present, special precautions shall be taken to comply with the safety standards established for the workplace.
- **Reporting problems or malfunctions** - The operator shall immediately report to a supervisor any problem(s) or malfunction(s) that become evident during operation. The operator shall ensure all problems and malfunctions that affect the safety of operations are repaired prior to continued use.
- **Capacity limitation** - Rated capacity shall not be exceeded when loads are transferred to the platform
- **Work area** - The operator shall ensure the area surrounding the machine is clear of personnel and equipment before lowering the load enclosure.
- **Securing the machine** - The operator shall comply with the means and procedures provided to protect against use by an unauthorized person(s).
- **Altering safety devices** - Safety devices shall not be altered or disabled.
- **Modifications** or alterations of the machine or the fabrication and attaching of frameworks or the mounting of attachments to the machine shall only be accomplished with prior written permission of the manufacturer.
- **Assistance to the operator** - If an operator encounters any suspected malfunction or any hazard or potentially unsafe condition relating to capacity, intended use or safe operation the operator shall cease operation of the machine and request further instruction from the owner/user.
- **Problems or malfunctions** - Any problem(s) or malfunction(s) that affect the safety of operations shall be repaired prior to the use of the machine.

## 2. Safety

All personnel installing, operating, and maintaining this machine shall read and understand this manual. For questions or concerns contact the manufacturer.

This machine shall be installed, operated, and maintained by trained and/or qualified personnel only.

### 2.1 Safety Alert Symbols

A symbol that indicates a hazard. It is composed of an equilateral triangle surrounding an exclamation mark. The safety alert symbol is only used on hazard alerting signs. It is not used on safety notice and safety instructions signs.



**A** – For use with **DANGER** signal word; (safety white triangle, safety red exclamation mark, safety red background)

**B** – For use with **WARNING** signal word; (safety black triangle, safety orange exclamation mark)

**C** – For use with **CAUTION** signal word; (safety black triangle, safety yellow exclamation mark)

**D** – For use with **DANGER, WARNING, or CAUTION** signal words; (**D** is a safety yellow triangle with a safety black border and safety black exclamation mark; [**E**] is a safety yellow triangle with a safety black exclamation mark and a safety yellow border around a safety black band)

### 2.2 Signal Words



**DANGER** Indicates a hazardous situation that, if not avoided, will result in death or serious injury.



**WARNING** Indicates a hazardous situation that, if not avoided, could result in death or serious injury.



**CAUTION** Indicates a hazardous situation that, if not avoided, could result in minor or moderate injury.



**NOTICE** Indicates information considered important, but not hazard-related (e.g., messages relating to property damage).

### 3. Labeling

This machine has labeling to indicate potential hazards this machine may pose when operating and/or maintaining the machine. All labels must be legible. If any label is missing, damaged, or otherwise illegible contact the manufacturer for replacement labels.

#### 3.1 Label Part Numbers & Quantity

#### 3.2 Label Location Diagram

Item	Part Number	QTY.
1	10079930	2
2	10088222	2.5 ft
3	10089457	2
4	10089458	2
5	2991041	1
6	C180N	3
7	10095524	1

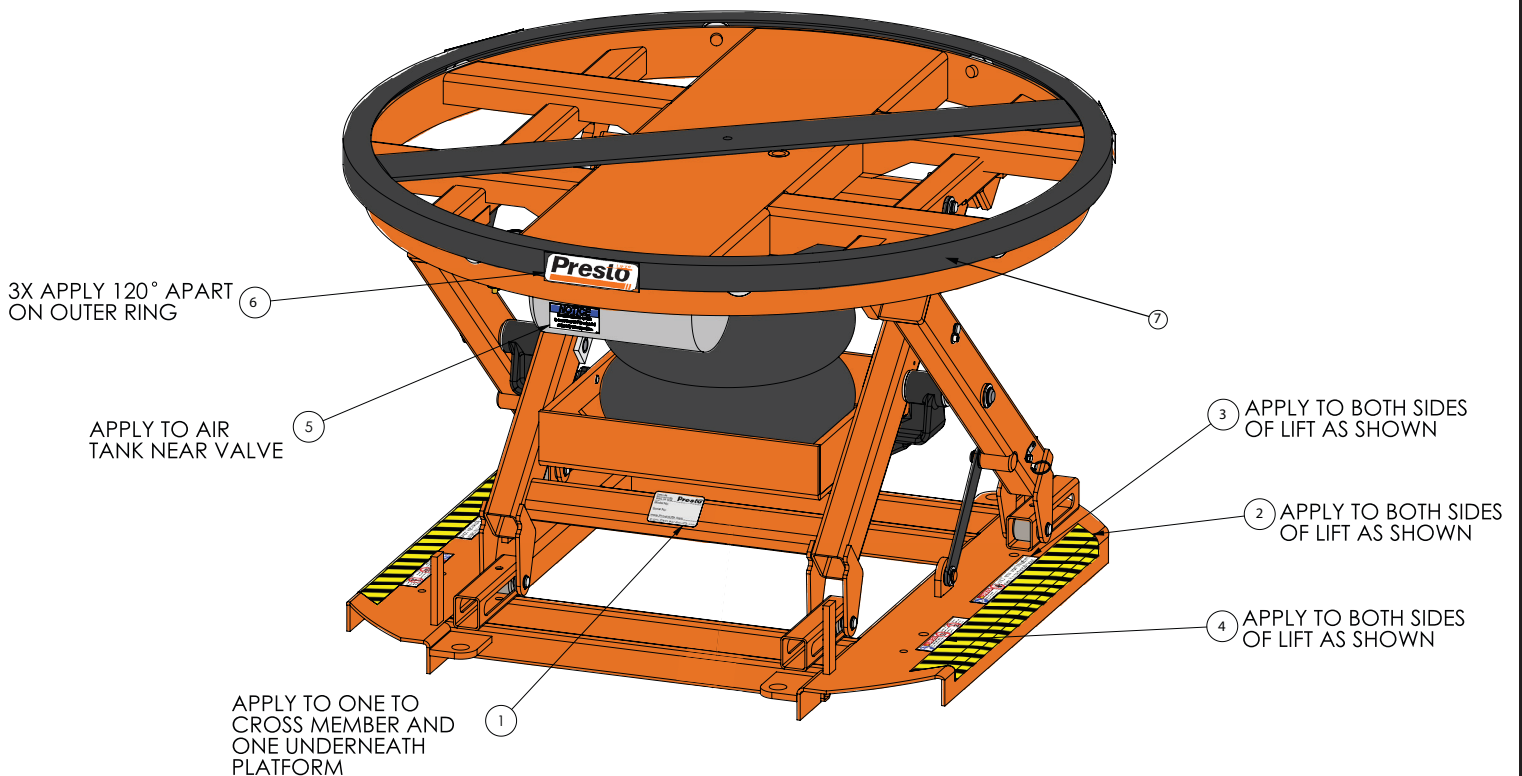



## 4. Setup

Upon receiving this machine, remove all packing material and check the machine and components for damage or missing parts. Contact the manufacturer if damage or missing parts are found.

### **WARNING**

The machine must only be used on flat, level surfaces. Uneven surfaces can cause instability when loading which could lead to the load falling and injuring the operator. The base frame must be level during use.

### **NOTICE**

To prevent damage to the machine, do not lag the machine to the floor.

### 4.1 Component Identification

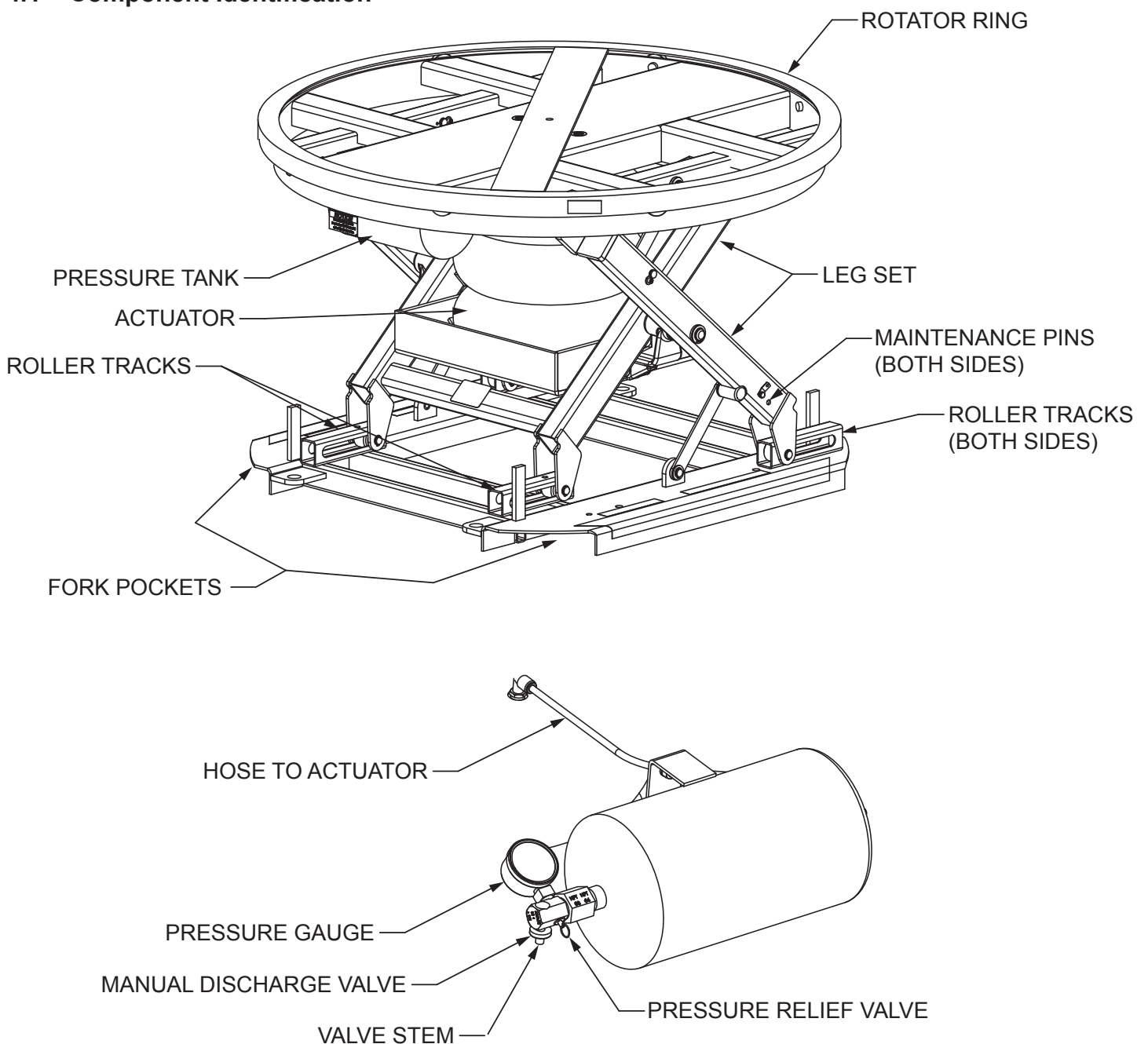

## 4.2 Machine Setup

### **NOTICE**

**Do not inflate the system to more than 30 PSI/2.1 Bar while unloaded and at the fully raised position. If system pressure exceeds 65 PSI/4.5 Bar failure can occur and cause damage to the machine and/or injury to the operator.**

1. Clear area of all packing material and other debris.
2. Carefully insert the forks of fork truck or stacker into the fork pockets of the machine. Raise the machine off of the shipping skid and remove the skid. Lower the machine onto the floor.
3. With no load on the machine, pressurize the system to 30 PSI/2.1 Bar via the valve stem on the pressure tank. Do not exceed 30 PSI /2.1 Bar.
4. Use a fork truck to gently place the heaviest expected load onto the platform. Load must not exceed 4,500 lb.
5. Slowly open the manual air discharge valve to release pressure from the system. Once the load is fully lowered, close the manual air discharge valve.

As the load is removed from the pallet, the lift will raise to maintain proper working height. Actual working height can be adjusted by increasing or decreasing the system pressure. Do not exceed 30 PSI /2.1 Bar when unloaded and in the fully raised position.

## 5. Operation

Before each use check the machine for damage or excess wear. If damage or excessive wear is found do not use the machine, contact the manufacturer for repair information and/or replacement parts.

### **⚠ WARNING**

Do not sit, stand, or ride on the machine.

Do not enter under the platform unless it is mechanically locked.

Keep hands, feet, and loose clothing away from moving parts.

Load and unload the machine gradually to avoid bouncing of the machine.

### **NOTICE**

Loads should be added and removed from the platform uniformly. Uneven loading can cause excessive wear and instability. Uneven loads can cause unintentional rotation of the turntable, which can cause the load to fall and lead to severe injury.

Do not use with damaged pallets or pallets with exposed fasteners. Damaged pallet pieces and/or fasteners must not extend more the 1/8" below the rotator ring.

This machine is to be operated and transported on flat, level surfaces only.

### 5.1 Manual Loading & Unloading

While loading and unloading manually, always keep the load as uniform across the platform as possible to avoid instability and excess wear. Always turn the platform slowly to avoid dislodging the load on the platform.

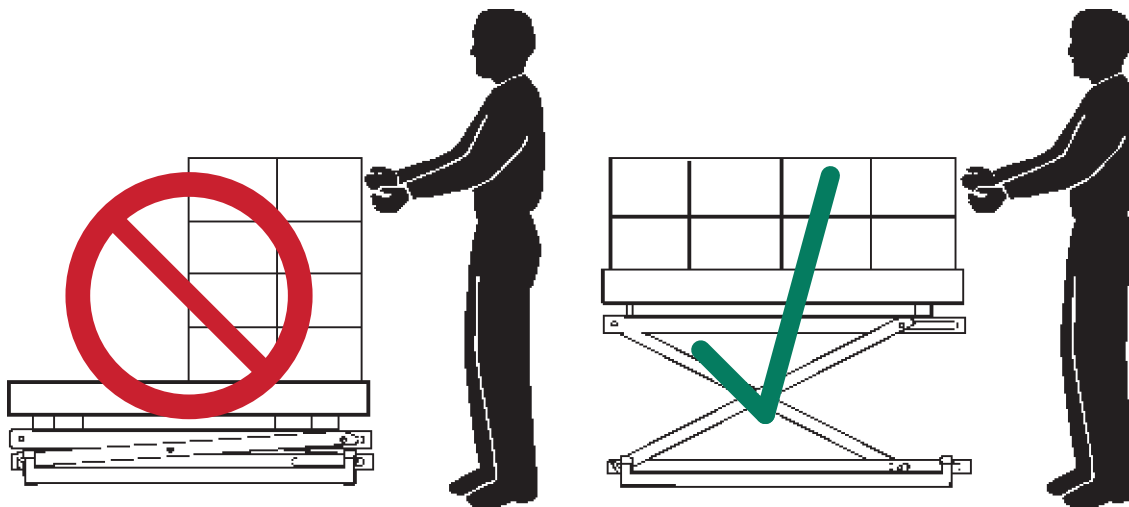

As the load is added and removed from the pallet, the height of the platform will raise or lower to maintain the proper working height. To adjust the working height, add or remove air from the system.

## 5.2 Fork Truck or Stacker Loading & unloading

When loading and unloading with a fork truck or stacker, the load should be distributed evenly on the pallet.

When placing a pallet onto the machine, slowly lower the pallet onto the platform until the load is completely supported by the machine. Slowly remove the forks from the pallet.

### **NOTICE**

**Do not drop the pallet onto the platform or damage may occur.**

When removing the load from the machine, slowly insert the forks into the pallet and slowly lift the pallet off the platform to avoid sudden changes in height which can damage the machine or cause injury.

## 5.3 Transporting

### **WARNING**

**Failure to secure the load and turntable while transporting can lead severe injury.**

**Do not drop the machine onto the floor or damage may occur.**

### **NOTICE**

**If equipped with a portability kit, always ensure the floor lock is engaged before using the machine.**

The machine can be transported with or without a load on the platform. If transporting the machine with a load on the platform, always secure the load to the platform and secure the turntable from rotating unintentionally.

The machine can be transported by an appropriately rated fork truck or stacker, or by the optional portability kits.

### 5.3.1 Transporting with Fork Trucks and Stackers

Insert the forks into the fork pockets and raise the machine off the floor. Move the machine to the desired location and lower the machine onto the floor. Remove the forks from the fork pockets.

### 5.3.2 Transporting with Portability Kits

#### 5.3.2.1 Caster Package

If equipped with the caster package, always engage the floor lock before loading and unloading. Disengage the floor lock to move the machine to the desired location.

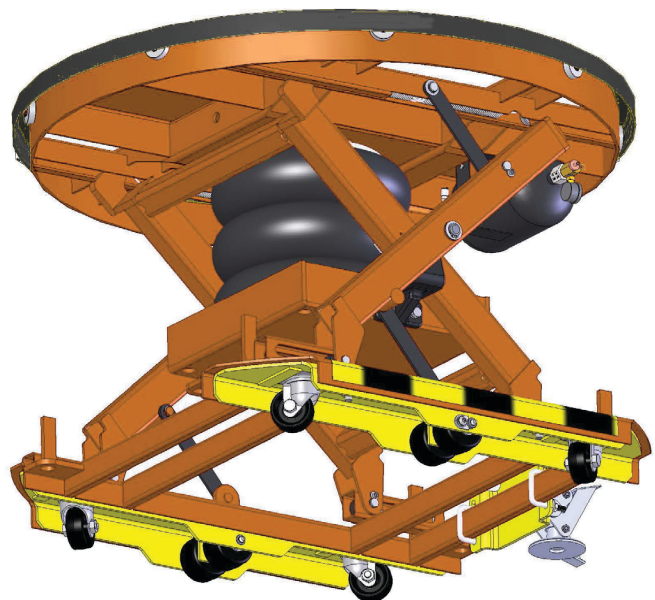

### 5.3.2.2 Leveling Feet

If equipped with the leveling feet package, the machine can be raised approximately three inches to accommodate the use of manual/ powered pallet jacks.

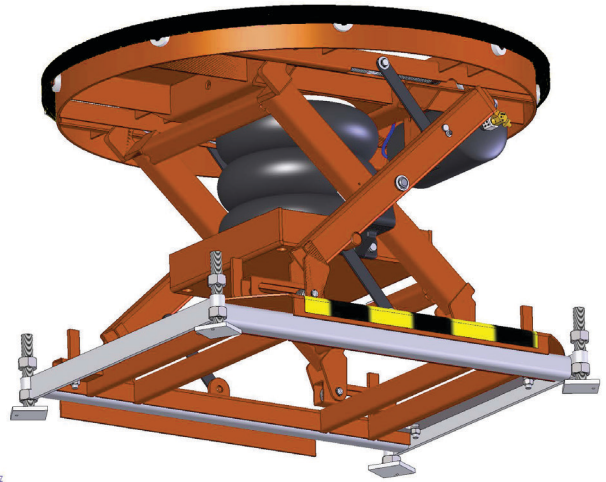

## 6. Maintenance & Repair

### **⚠ WARNING**

Only trained and/or qualified personnel shall perform maintenance on this machine.

Never perform maintenance on the machine while a load is on the platform.

Do not enter under the platform unless it is mechanically locked.

High pressure air can cause severe injury. Always relieve the pressure in the system before performing maintenance.

### 6.1 Maintenance Pins

1. With the machine in the raised position and the load removed, remove the maintenance pin from the stowed position on the leg, near the roller.
2. Insert the pins into the hole in the top of the roller track (both sides).

### **NOTICE**

If not supplied with maintenance pins, two 3/8" diameter by 3" long bolts may be used instead.

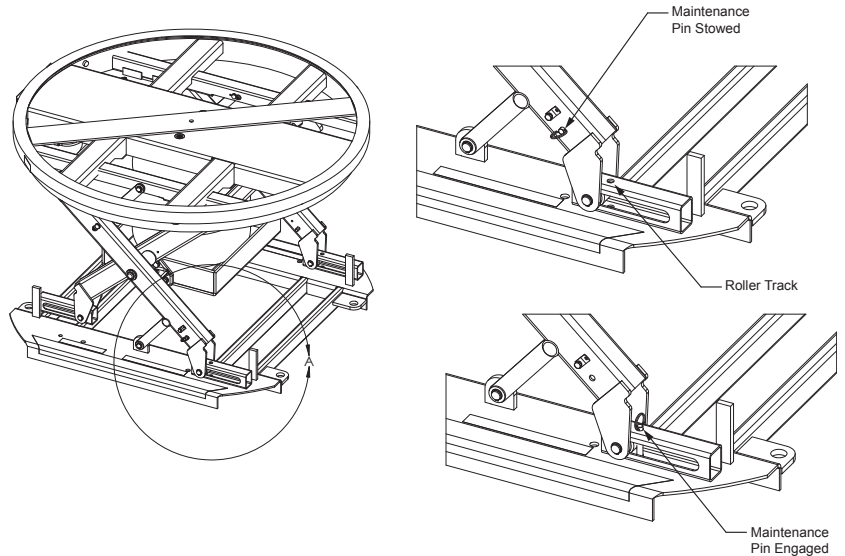

## 6.2 Periodic Maintenance

**Before each use** inspect the machine for damage or wear. If damage or wear is found remove the machine from service and repair before using.

### 6.2.1 Weekly

- Inspect upper and lower rollers, roller pins and bushings, and roller tracks. Replace as necessary.
- Inspect upper and lower hinge pins and bushings. Replace as necessary.
- Inspect motion actuator for signs of leaking and/or damage. Repair/replace as necessary.
- Inspect center pins and bushings. Replace as necessary.
- Inspect rotator ring, rotator ring washer, and bearings. Ensure the rotator rings rotates smoothly without binding. Repair or replace bearings as necessary.
- Inspect base frame, platform, and leg set for wear or damage.

### 6.2.2 Every Six Months

- Perform weekly maintenance
- Apply dry PTFE lubricant to all pivot points, rollers, and bearings.

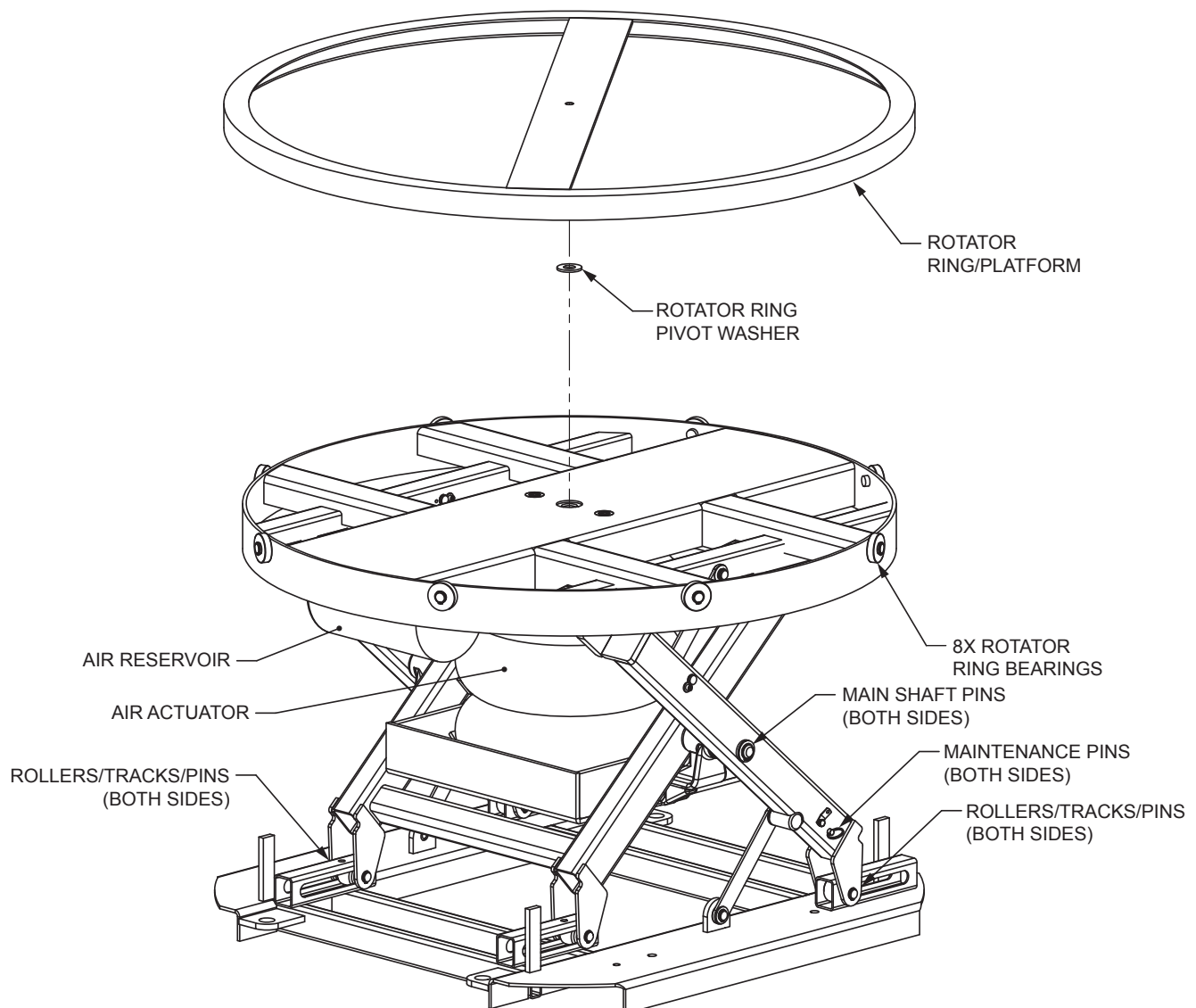

### **6.3 Ordering Replacement Parts**

Presto has carefully chosen the components in your unit to be the best available for the purpose. Replacement parts should be identical to the original equipment. Presto will not be responsible for equipment failures resulting from the use of incorrect replacement parts or from unauthorized modifications to the unit.

Presto can supply all replacement parts for your machine. With your order, please include the model number and the serial number of the unit. You can find these numbers on the name plate. This plate is located within the scissors mechanism.

To order replacement parts, please call the Parts Department at 800-343-9322. Parts are shipped subject to the following terms:

- FOB factory
- Returns only with the approval of our parts department.
- Payment net 30 days (except parts covered by warranty).
- Freight collect (except parts covered by warranty).
- The warranty for repair parts is 30 days from date of shipment.

Parts replaced under warranty are on a “charge-credit” basis. We will invoice you when we ship the replacement part, then credit you when you return the worn or damaged part, and we verify that it is covered by our warranty. Labor is not covered under warranty for Parts orders.



## 7. Troubleshooting

Problem	Possible Cause	Possible Solutions
The unit lowers too easily or too early.	Not enough air pressure in the system.	Add air to the system.
The unit does not lower enough or too late.	Too much air pressure in the system.	Relieve the pressure in the system.
The turntable turns unintentionally.	The base frame may not be level or the load on the platform is not uniform.	Ensure the base frame is level and the machine is loaded uniformly.
Excessive vibration or noise while rotating.	One or more bearings may be broken.	Check the bearings supporting the turntable. Replace any broken or excessively worn bearings.
Wear on the underside of the turntable	Normal condition cause by work hardening of the metal.	No repair necessary.

## 8. Warranty & Contact Information

Presto Lifts warrants this product to be free from defects in material or workmanship for the duration of the warranty period. Warranty periods vary and begin on the date of shipment. For specific warranty information, contact Presto Lifts with the machine's serial number.

Any claim for breach of this warranty must be received in writing by Presto within the warranty period. Warranties shall not cover failure or defective operation, caused by misuse, misapplication, negligence or accident, exceeding recommended capacities, or any alteration or repair of the item purchased which has not been authorized by Presto. Except as set forth herein, Presto makes no other warranties, express or implied, including THE WARRANTIES OF MERCHANTABILITY AND OF FITNESS FOR A PARTICULAR PURPOSE, all of which ARE HEREBY EXCLUDED.

Presto meets the labeling requirements of California's Proposition 65. Presto makes no warranty or representation with respect to the compliance of any product with other State or local safety or product standard codes and any failure to comply with such codes shall not be considered a defect of material or workmanship under this warranty. Presto shall not be liable for any direct or consequential damages arising out of such non-compliance.

Presto's obligations under any warranty or for any other damages which may arise under any sale, agreement, or contract, are limited to the replacement or repair of defective components at its factory or another location at Presto's discretion. This is buyer's sole remedy under any such warranty, sale, agreement, or contract. Presto will not be liable for consequential, incidental, exemplary, or punitive damages of any kind resulting from a breach of any warranty that it has provided or for breach of any term of any sale, agreement, or contract. Any warranty may be altered only in writing by Presto.

All commodities, software, or technology purchased from Presto are subject to the export and re-export control laws and regulations of the United States, including but not limited to the Export Administration Regulations ("EAR") and Department of the Treasury Office of Foreign Asset Controls ("OFAC") Regulations. Presto expects all distributors and customers to comply with these laws and regulations. Without limiting the foregoing, the distributor/customer cannot, without proper authorization from the applicable United States Government Agency, export, re-export, or transfer any commodity, software, or technology purchased from Presto, either directly or indirectly, to any entity, country, or national of any country in breach of such laws and regulations. Furthermore, Presto expects that the distributor/customer shall indemnify and hold harmless Presto from and against any claim, proceeding, action, fine, loss, cost and damages arising out of or relating to any noncompliance with export control regulations by distributor/customer, and distributor/customer are expected to compensate Presto for all losses and expenses resulting thereof, unless such noncompliance was clearly not caused by fault of the distributor/customer.

Presto Lifts Inc.  
50 Commerce Way, Norton, MA 02766  
Phone: 800.343.9322  
Fax: 888.788.6496  
www.PrestoLifts.com  
Email: [service@prestolifts.com](mailto:service@prestolifts.com)

