



P3 All-Around Spring Load Leveler (Spring Ranges 0, 1, 2, 3, & 4)



Model: _____
Serial Number: _____
Date placed in service: _____

Presto Lifts Inc.
2 Hampshire Street, Suite 102
Foxborough, MA 02035
800.343.9322 | Fax: 888.788.6496
service@prestolifts.com
www.PrestoLifts.com

**Owner
Manual**

Contents

If viewing this manual electronically, just left click any section below to immediately view that area.

To get back to the table of contents, just click in area to the outside of the left border.

1	INTRODUCTION.....	4
1.1	Responsibilities of Owner and Users	4
1.2	Responsibilities of Operators	5
2	SAFETY	7
2.1	Safety Alert Symbols	7
2.2	Signal Words.....	7
3	LABELING	8
3.1	Label Placement Diagram.....	8
3.2	Labels	9
4	INSTALLATION & SETUP	10
4.1	Key Components	11
4.2	Range Configurations & Spring Selections.....	12
4.3	Bayonet with Cliplock Positions	13
4.4	Range 0 Setup (Main Spring - White Only).....	14
4.5	Range 1 Setup (Main Spring - Orange Only).....	19
4.6	Range 2 - 4 Setup (Secondary Springs - Gray & Purple)	20
4.7	Removing the Main Spring(s) - White or Orange.....	22
5	OPERATION.....	26
5.1	Loading & Unloading.....	27
5.1.1	Manually	27
5.1.2	Fork Truck or Stacker	27
5.2	Transporting the Machine	28
5.2.1	Fork Truck or Stacker	28
5.2.2	Portability Kit - Casters	28
5.2.3	Portability Kit - Leveling Feet.....	29
5.3	Operation Video	29

6	MAINTENANCE & REPAIR	30
6.1	Maintenance Devices.....	30
6.2	Periodic Maintenance	30
6.2.1	Weekly.....	30
6.2.2	Semi-Annually (Every Six Months).....	30
6.3	Replacement Parts	31
7	TROUBLESHOOTING.....	32
8	WARRANTY & CONTACT INFORMATION	33

⚠ WARNING
Cancer and Reproductive Harm - www.P65Warnings.ca.gov

This label (part # 10095524) is required by California Law. For more information visit: www.P65Warnings.ca.gov

1 INTRODUCTION

1.1 Responsibilities of Owner and Users

Basic Principles - Owners/users shall apply sound principles of safety, training, inspection, maintenance to the expected operating environment. It shall be the responsibility of the owner/user to advise the manufacturer where deflection may be critical to the application.

Manuals - Owners/users shall keep and maintain a copy of the operating and maintenance manual(s) and ensure its availability to operating and maintenance personnel.

Inspection and Maintenance - It shall be the responsibility of the users to inspect and maintain the machine as required to ensure proper operation. The frequency of inspection and maintenance shall be based upon the manufacturer's recommendations and be compatible with operating conditions and the severity of the operating environment. Machinery that is not in proper operating condition shall be immediately removed from service until repaired. Maintenance and repairs shall be made by a qualified person and the repairs shall be in conformance with the manufacturer's recommendations.

Maintenance Safety Precautions - Before adjustments and repairs are started on the machine, the following precautions shall be taken as applicable:

1. Remove the load from the platform.
2. Lower platform to the full down position.
3. Relieve system pressure from all circuits before loosening or removing any components.
4. All controls in the "off" position and all operating features secured from inadvertent motion by brakes, blocks, or other means.
5. Disconnect power and follow established owner/user lockout/tag out policies.
6. Follow precautions and directions as specified by the manufacturer.

Replacement Parts - When parts or components are replaced, they shall be replaced with parts or components approved by the original manufacturer.

Maintenance Training - The user shall ensure only qualified personnel inspect and maintain the machine in accordance with the manufacturer's recommendations.

Operator Training - An owner/user, who directs or authorizes an individual to operate the machine shall ensure that the individual has been:

1. Trained in accordance with the manufacturer's operating manual.
2. Made aware of the responsibilities of operators as outlined in section 1.2 of this manual.
3. Retrained, if necessary, based on the owners/user's observation and evaluation of the operator.

Modifications and additions shall not be performed without the manufacturer's prior written approval. Where such authorization is granted, capacity, operation, and maintenance instruction plates, tags, or decals shall be changed accordingly.

1.2 Responsibilities of Operators

Basic Principles - Operators shall apply sound principles of safety and good judgment in the application, and operation of the machine with consideration given to its intended use and expected operating environment. Since the operator is in direct control of the machine, conformance with good safety practices is the responsibility of the operator. The operator shall make decisions on the use and operation with due consideration for the fact that his or her own safety as well as the safety of other personnel on or near the machine is dependent on those decisions.

General Training - Only personnel who have received general instructions regarding the inspection, application, and operation of machine, including recognition and avoidance of hazards associated with their operation, shall operate the machine. Such topics covered shall include, but not necessarily be limited to, the following issues and requirements:

1. A pre-start inspection
2. Responsibilities associated with problems or malfunctions affecting the operation of the machine
3. Factors affecting stability
4. The purpose of placards and decals
5. Workplace inspection
6. Safety rules and regulations
7. Authorization to operate
8. Operator warnings and instructions
9. Actual operation of the machine. Under the direction of a qualified person, the trainee shall operate the machine for a sufficient period of time to demonstrate proficiency in actual operation of the machine.

Pre-start Inspection - Before use each day or at the beginning of each shift, the machine shall be given a visual inspection and functional test including but not limited to the following:

1. Operating and emergency controls
2. Safety devices
3. Hydraulic system leaks
4. Electrical cables and wiring harness
5. Loose or missing parts
6. Nameplates, precautionary and instructional markings and/or labeling
7. Guarding system
8. Items specified by the manufacturer

Problem or Malfunctions - Any problems or malfunctions that affect the safety of operations shall be repaired prior to the use of the machine.

Before Operations - The operator shall:

1. Read and understand the manufacturer's operating instruction(s) and user's safety rules or have them explained.
2. Understand all labels, warnings, and instructions displayed on the machine or have them explained.

Workplace Inspections - Before the machine is used and during use, the operator shall check the area in which the machine is to be used for possible hazards such as, but not limited to:

1. Bumps, floor obstructions, and uneven surfaces
2. Overhead obstructions and electrical hazards
3. Presence of unauthorized persons
4. Other possible unsafe conditions as noted in the operating manual.

Operator Warnings and Instructions - The operator shall ensure the operation of the machine is in compliance with the following:

1. **Guarding system** - Guarding shall be installed and positioned, and access gates or openings shall be secured per the manufacturer's instructions (If applicable).
2. **Distribution of load** - The load and its distribution on the platform shall be in accordance with the manufacturer's rated capacity for that specific configuration.
3. **Maintaining overhead clearance** - The operator shall ensure that adequate clearance is maintained from overhead obstructions and energized electrical conductors and parts.
4. **Point of Operation** - The operator shall not place any part of their body under the platform.
5. **Precaution for moving equipment** - When other moving equipment or vehicles are present, special precautions shall be taken to comply with the safety standards established for the workplace.
6. **Reporting problems or malfunctions** - The operator shall immediately report to a supervisor any problem(s) or malfunction(s) that become evident during operation. The operator shall ensure all problems and malfunctions that affect the safety of operations are repaired prior to continued use.
7. **Capacity limitation** - Rated capacity shall not be exceeded when loads are transferred to the platform.
8. **Work area** - The operator shall ensure the area surrounding the machine is clear of personnel and equipment before lowering the platform.
9. **Securing the machine** - The operator shall comply with the means and procedures provided to protect against use by an unauthorized person(s).
10. **Altering safety devices** - Safety devices shall not be altered or disabled.
11. **Modifications** or alterations of the machine or the fabrication and attaching of frameworks or the mounting of attachments to the machine or the guarding system shall only be accomplished with prior written permission of the manufacturer.
12. **Assistance to the operator** - If an operator encounters any suspected malfunction or any hazard or potentially unsafe condition relating to capacity, intended use, or safe operation, the operator shall cease operation of the machine and request further instruction from the owner/user.
13. **Problems or malfunctions** - Any problem(s) or malfunction(s) that affect the safety of operations shall be repaired prior to the use of the machine.

2 SAFETY

All personnel installing, operating, and maintaining this machine shall read and understand this manual. For questions or concerns contact the manufacturer.

This machine shall be installed, operated, and maintained by trained and/or qualified personnel only.

2.1 Safety Alert Symbols



A symbol that indicates a hazard. It is composed of an equilateral triangle surrounding an exclamation mark. The safety alert symbol is only used on hazard alerting signs. It is not used on safety notice and safety instructions signs.

A – For use with **DANGER** signal word; (safety white triangle, safety red exclamation mark, safety red background)

B – For use with **WARNING** signal word; (safety black triangle, safety orange exclamation mark)

C – For use with **CAUTION** signal word; (safety black triangle, safety yellow exclamation mark)

D – For use with **DANGER, WARNING, or CAUTION** signal words; (**D** is a safety yellow triangle with a safety black border and safety black exclamation mark)

2.2 Signal Words



DANGER Indicates a hazardous situation that, if not avoided, will result in death or serious injury.



WARNING Indicates a hazardous situation that, if not avoided, could result in death or serious injury.



CAUTION Indicates a hazardous situation that, if not avoided, could result in minor or moderate injury.



NOTICE Indicates information considered important, but not hazard-related (e.g., messages relating to property damage).

3 LABELING

This machine has labeling to indicate potential hazards this machine may pose when operating and/or maintaining the machine. All labels must be legible. If any label is missing, damaged, or otherwise illegible contact the manufacturer for replacement labels.

3.1 Label Placement Diagram

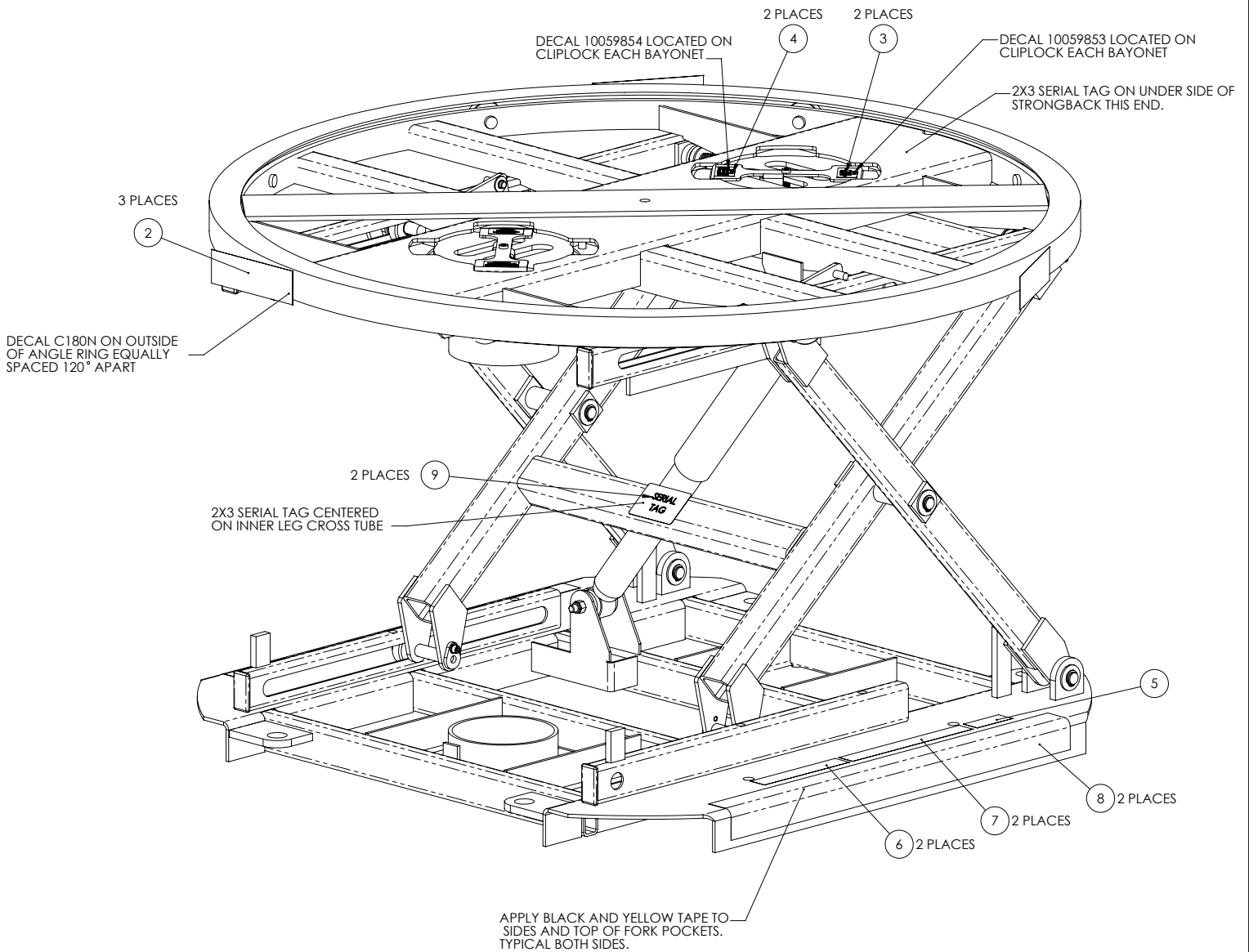

9	2	EA	LD DCL 2.00X3.00 PRESTO SERIAL ID BLANK	10079930
8	6	FT	CAD TAPE 3" BLK/YLW SAFETY	10088222
7	2	EA	LD DCL 1.00X8.50 TO AVOID BODILY INJURY,	10089457
6	2	EA	LD DCL 1.00X6.00 A DANGER TO AVOID BODIL	10089458
5	1	EA	LD WARNING CANCER AND REPRODUCTIVE	10095524
4	2	EA	LD DCL 1.75X1.00 TO UNLOCK	10059854
3	2	EA	LD DCL 1.75X1.00 TO LOCK	10059853
2	3	EA	BK-LD 1.62X7.00 PRESTO ALPHA	C180N
1				
ITEM NO.	QTY.	U/M	DESCRIPTION	PART NO.

3.2 Labels

2



3

TO LOCK
Rotate yellow
bayonet and drop
cliplock flush.

4

TO UNLOCK
Raise black cliplock
and rotate to align with
yellow bayonet handle

5



6



7



8



9



4 INSTALLATION & SETUP

Remove all packaging. Inspect the machine for damage. Verify all components were received. If damage is found or components are missing do not continue the setup procedure; contact customer service. Review **Key Components** section. The Presto P3 All-Around Spring Load Leveler comes in a standard orange color, but there will be other images represented throughout this manual that illustrate colors other than standard.

WARNING

Do not enter beneath the platform unless the platform is secured against lowering.

The machine must only be installed and used on flat, level surfaces. Uneven surfaces can cause instability when loading which could lead to the load falling and injuring the operator.

During installation pinch points may exist. Keep hands, feet, and loose clothing away from moving parts.

Do not sit stand or ride on the platform/rotator ring.

Installation of the main (orange for Range 1, 2, 3 or 4, white for Range 0) spring requires two people. Do not attempt to set the machine up with only one person.

⋮
⋮
⋮

This machine does not need to be lagged to the floor.

4.1 Key Components

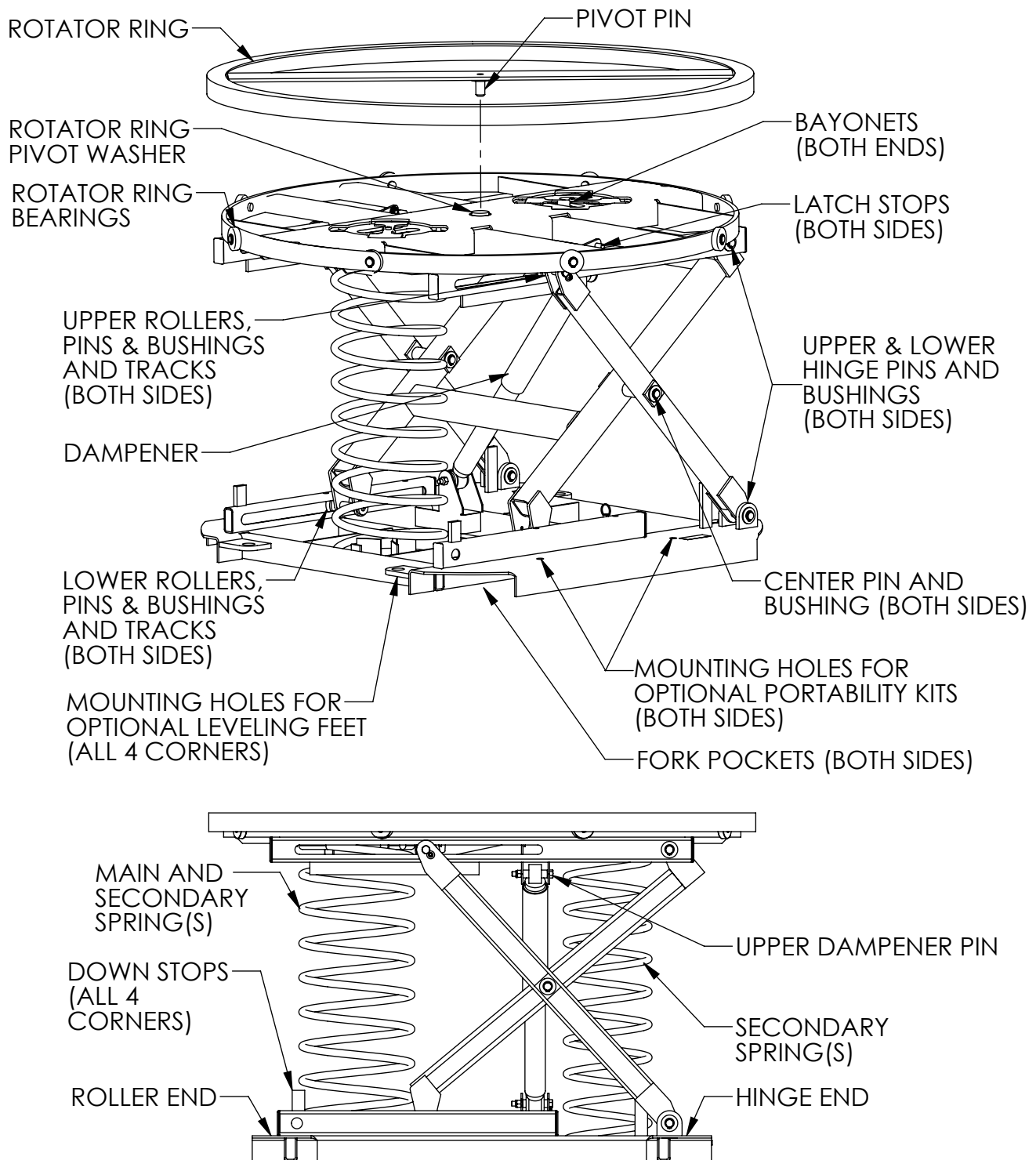

Note: The rotator ring may be ordered as a solid round or rectangular top, or ordered with a locking device. The rotator ring may also not be included at all.

4.2 Range Configurations & Spring Selections

The P3 All-Around Spring Load Leveler is available in five possible spring configurations or ergonomic ranges.

The springs are typically black in color overall and can be identified with additional paint markings on the ends. Colors include white, orange, purple or gray. Spring configurations are chosen to operate best within a specific load weight/height range. If the load height and/or weight changes, a different spring configuration may be needed. See the **Spring Selection Chart** below for springs required for the specific ranges. If necessary, additional springs may be ordered. Contact customer service for more information.

NOTICE

See range configurations in chart below to determine springs used for each.

P3 All-Around Spring Load Leveler springs are calibrated and will work best within the load weight and height ranges selected. Selection based on higher or lower than actual weight will result in restricted raising or lowering capability. Should pallet weight or height weight requirements change, the springs can be adapted in the field at any time by simply changing the spring combination used.

		Weight of Fully Loaded Pallet											
		0-400 lb. 0-180 kg	400 -800 lb. 80-360 kg	800 -1200 lb. 360-540 kg	1200 -1600 lb. 540-720 kg	1600 -2000 lb. 720-900 kg	2000 -2400 lb. 900-1080 kg	2400 -2800 lb. 1080-1260 kg	2800 -3200 lb. 1260-1440 kg	3200-3600 lb. 1440-1620 kg	3600 -4000 lb. 1620-1800 kg	4000 -4500 lb. 1800-2025 kg	
0	Range 0 White Spring Only	58-60 in. 1473-1524 mm	0	0	1	1	1	1	2	2	2	3	3
		56-58 in. 1422-1473 mm	0	0	1	1	1	2	2	2	2	3	3
1	Range 1 Orange Spring Only	54-56 in. 1372-1422 mm	0	0	1	1	1	2	2	2	2	3	3
		52-54 in. 1321-1372 mm	0	1	1	1	1	2	2	2	3	3	3
2	Range 2 Orange & Gray Springs	50-52 in. 1270-1321 mm	0	1	1	1	1	2	2	2	3	3	4
		48-50 in. 1219-1270 mm	0	1	1	1	1	2	2	2	3	3	4
3	Range 3 - Orange & Purple Springs	46-48 in. 1168-1219 mm	0	1	1	1	1	2	2	3	3	3	4
		44-46 in. 1118-1168 mm	0	1	1	1	2	2	3	3	3	4	4
4	Range 4 Orange, Gray, & Purple Springs	42-44 in. 1067-1118 mm	0	1	1	2	2	2	3	3	4	4	4
		40-42 in. 1016-1067 mm	0	1	1	2	2	3	3	3	4	4	4
		38-40 in. 965-1016 mm	0	1	1	2	2	3	3	4	4	4	4
		36-38 in. 914-965 mm	0	1	1	2	2	3	4	4	4	4	4
		34-36 in. 864-914 mm	1	1	2	2	3	3	4	4	4	4	---
		32-34 in. 813-864 mm	1	1	2	3	3	4	4	4	4	---	---
		30-32 in. 762-813 mm	1	1	2	3	3	4	4	4	4	---	---

See **Key Components** section to determine the hinge vs. the roller end.

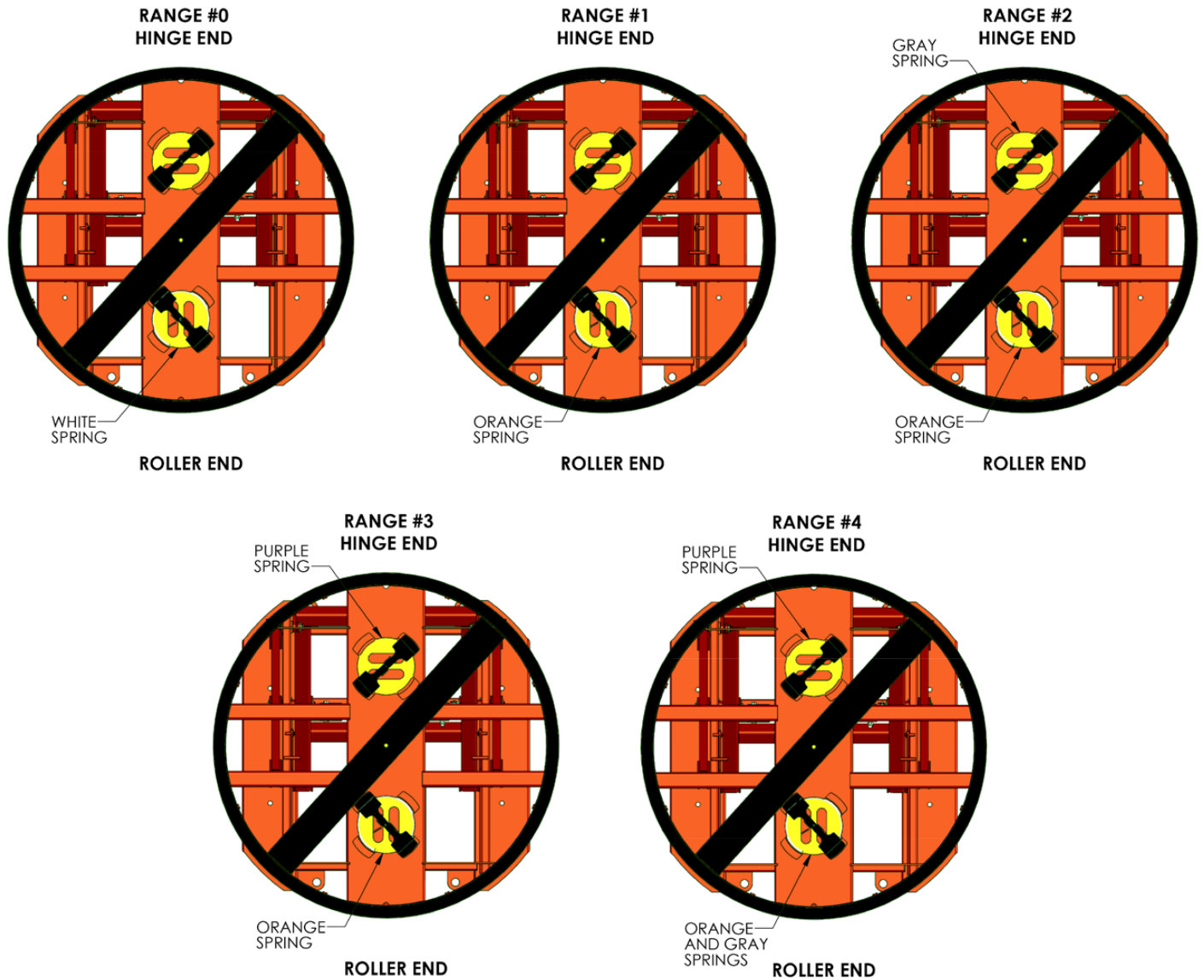

4.3 Bayonet with Cliplock Positions

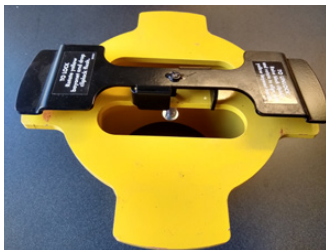

BAYONET WITH CLIPLOCK



INITIAL BAYONET POSITION IN PLATFORM



BAYONET TURNED 45 DEGREES CW



CLIPLOCK TURNED 45 DEGREES CCW AND LOWERED TO LOCK

4.4 Range 0 Setup (Main Spring - White Only)

Range 0 units are supplied with a single white spring. This spring is sometimes installed at the factory and the unit shipped in the raised position. If this is the case upon receipt, inspect the P3 All-Around Spring Load Leveler for damage. No further setup is necessary.

For Range 0 units that have not been shipped in the raised position, continue to the steps below.

1. Remove the rotator ring by lifting it off of the platform. Set the ring aside in a safe location.

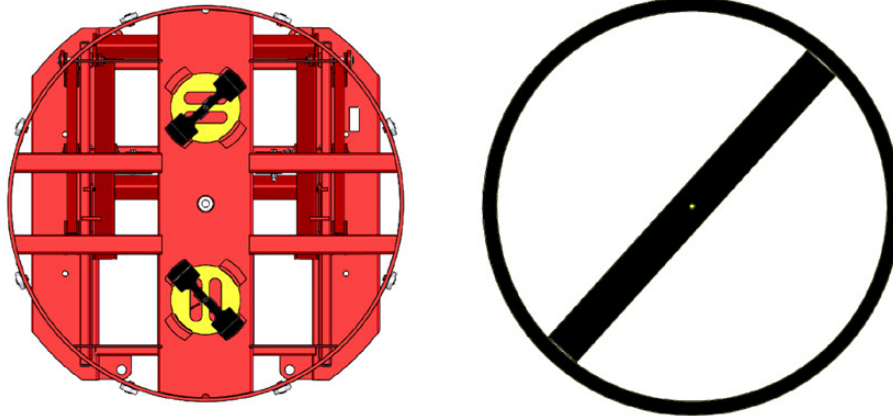

2. Note the position of the dampener and pin located near the middle of the base from under the platform. Remove the pin securing the dampener to the platform. Allow the dampener to rest on the floor.



3. With two people, lift the platform until the roller pins contact the upper latch stops located on the platform on both sides.



- Lift the latch stops and hold them up. Continue to lift the platform until it reaches its fully raised position.

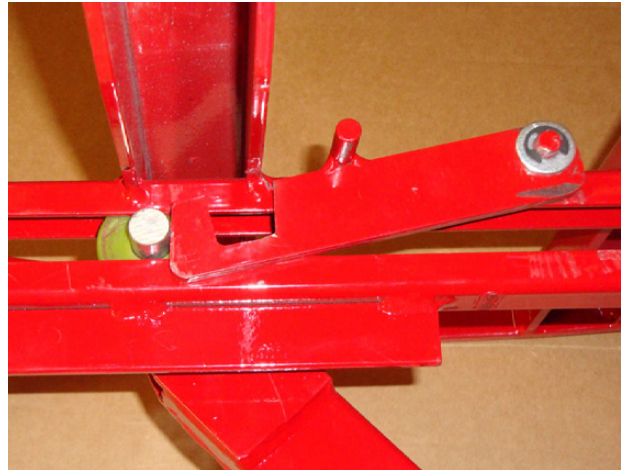
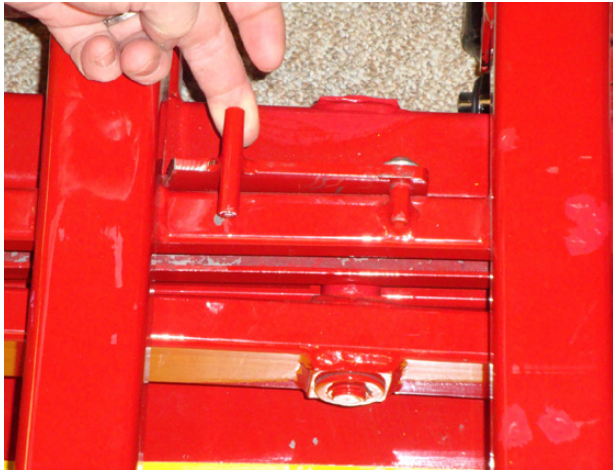

- While one person holds the platform up the second person places the dampener pin into the hole in the roller track nearest to the hinge end to hold the platform in place.



- Remove the roller end bayonet by lifting the cliplock and turning 45 degrees CW, then turning the bayonet 45 degrees CCW and lift out. Place the bayonet aside in a safe location.



BAYONET WITH CLIPLOCK



TO UNLOCK , LIFT CLIPLOCK



TURN CLIPLOCK 45 DEGREES CW



TURN BAYONET 45 DEGREES CCW AND LIFT TO REMOVE

7. Insert either end of the white (orange shown to left and right below) spring into the lower spring pocket on the roller end of the base frame. Ensure the spring is positioned outside the alignment tab.

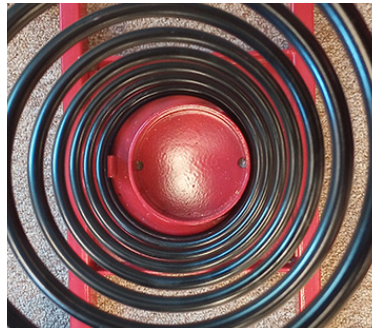

WHITE SPRING
OUTSIDE ALIGNMENT TAB



ORANGE SPRING
OUTSIDE ALIGNMENT TAB

8. Grasp the spring by the second or third coil down from the top, compress the spring and slide the top of the spring into the upper spring pocket.



⚠ CAUTION

Do not grasp the top coil of the spring or your hands/finger may be crushed when sliding the spring into the pocket.

9. Verify the spring (white shown left two images below) is properly seated in the upper spring pocket. The top of the springs should be completely within the pocket.

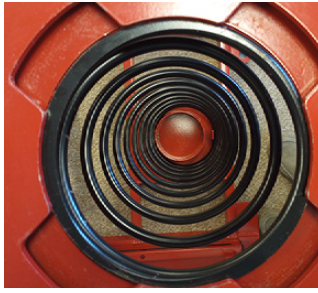

WHITE SPRING PROPERLY POSITIONED IN UPPER POCKET



WHITE SPRING IMPROPERLY POSITIONED IN UPPER POCKET



ORANGE SPRING PROPERLY POSITIONED IN UPPER POCKET



ORANGE SPRING IMPROPERLY POSITIONED IN UPPER POCKET

10. Reinstall the yellow bayonet by inserting it into the bayonet opening and turning it clockwise into the locked position. The bayonet will need to be pushed down slightly before turning when the white spring is installed. Secure with the black clip locks.



BAYONET WITH CLIPLOCK



PLACE BAYONET IN PLATFORM



TURN BAYONET 45 DEGREES CW



TURN CLIPLOCK 45 DEGREES CCW AND LOWER TO LOCK

11. Remove the dampener pin. It will pull out easier if someone is lifting up on the platform at the same time. The spring will hold the platform elevated with the bayonet in place.



12. Press down on the platform until the two latches fall into place. The latches will fall in behind the roller pins.

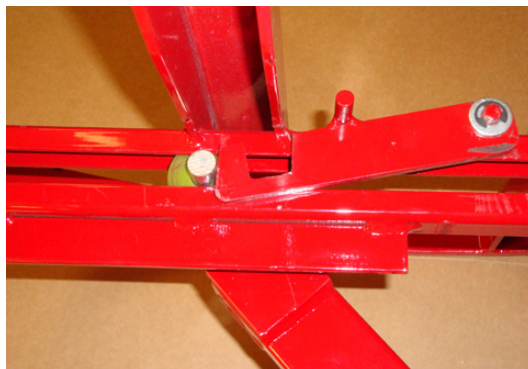

13. Reinstall the dampener and secure with the pin.



14. Place turntable ring back on top of platform and turn to make sure it is aligned with the rollers.

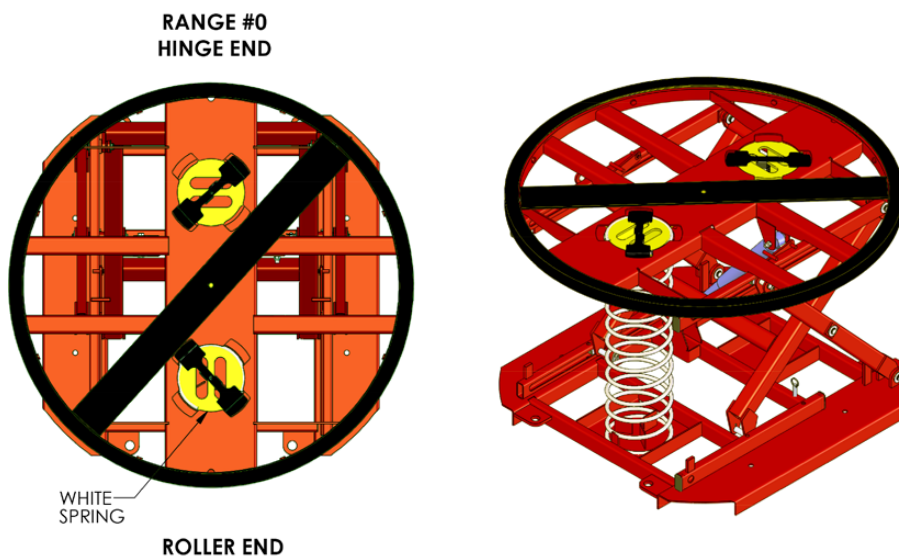

15. The P3 All-Around Spring Load Leveler Range 0 is now ready for use.

4.5 Range 1 Setup (Main Spring - Orange Only)

A Range 1, 2, 3 or 4 unit will always be supplied with at least one spring. This spring can be identified by an orange mark and larger diameter. This is assembled in the same way as the instructions illustrate in the Range 0 Setup section.

1. To set up the Range 1 unit, use the instructions in the **Range 0 Setup** section, steps 1 through 14 installing the orange spring rather than the white spring.

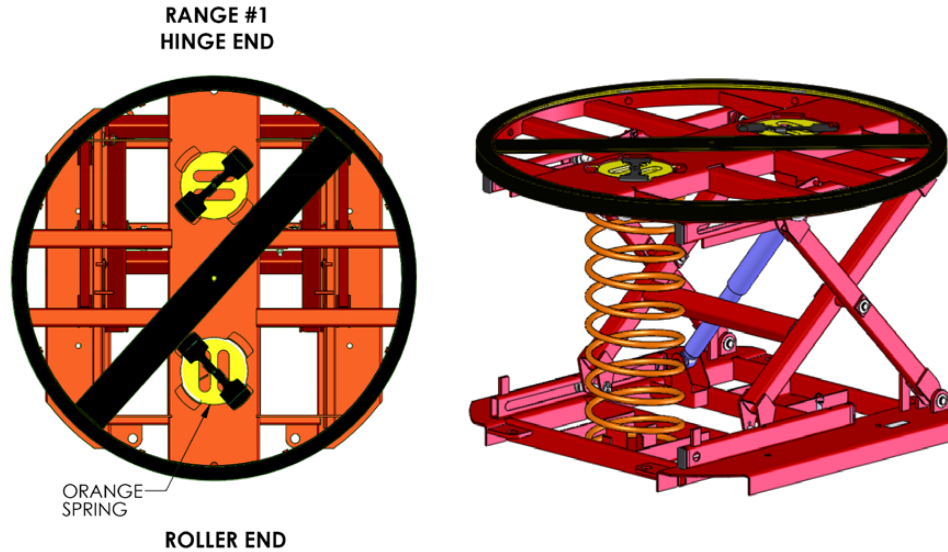

2. The P3 All-Around Spring Load Leveler Range 1 is now ready for use.

4.6 Range 2 - 4 Setup (Secondary Springs - Gray & Purple)

Once the Range 1 is set up, setting up the Range 2, 3, or 4 is quite simple. There will be no need to remove the turntable top to complete this setup, unless set up with a solid top. Changing back and forth between Range 1, 2, 3 or 4 is only a matter of lowering springs into or pulling springs out of the appropriate bayonet openings. See item 2 images below for each range.

1. Remove the bayonet(s) by lifting the cliplock and turning 45 degrees CW, then turning the bayonet 45 degrees CCW and lifting out. Place the bayonet(s) aside.



BAYONET WITH CLIPLOCK



TO UNLOCK, LIFT CLIPLOCK



TURN CLIPLOCK 45 DEGREES CW



TURN BAYONET 45 DEGREES CCW AND LIFT TO REMOVE

2. Insert or exchange gray and/or purple springs for the configuration required.

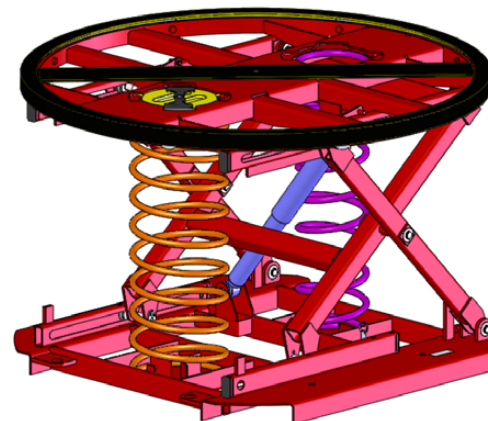
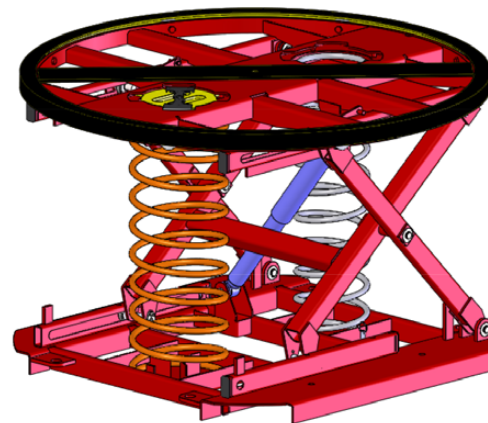
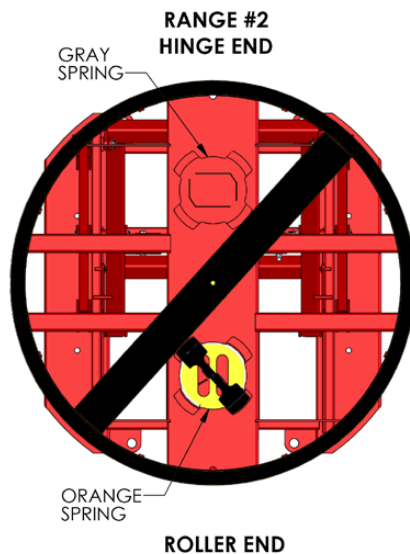

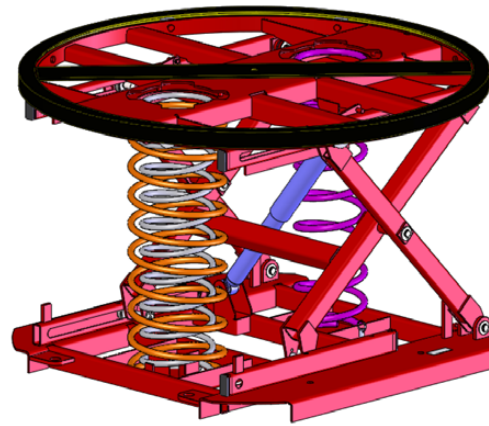

3. After appropriate spring(s) are in place, install the yellow bayonet(s) by inserting them into the bayonet openings and turning them clockwise into the locked position. Secure with the black clip locks.



BAYONET WITH CLIPLOCK



PLACE BAYONET IN PLATFORM



TURN BAYONET 45 DEGREES CW



TURN CLIPLOCK 45 DEGREES CCW AND LOWER TO LOCK

4. The P3 All-Around Spring Load Leveler Range 2, 3, or 4 is now ready for use.

4.7 Removing the Main Spring(s) - White or Orange

Whether removing the white spring for the Range 0 unit or the orange spring for the Range 1 unit, the following procedure is the same.

1. Remove the rotator ring by lifting it off of the platform. Set the ring aside in a safe location.

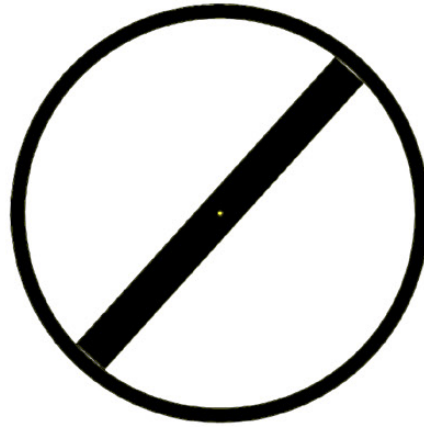
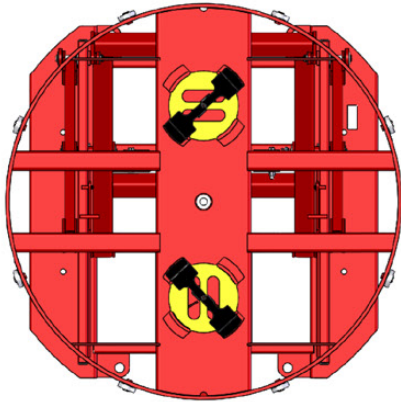

2. Note the position of the dampener and pin located near the middle under the platform. Remove the pin securing the dampener to the platform. Allow the dampener to retract and rest on the floor.

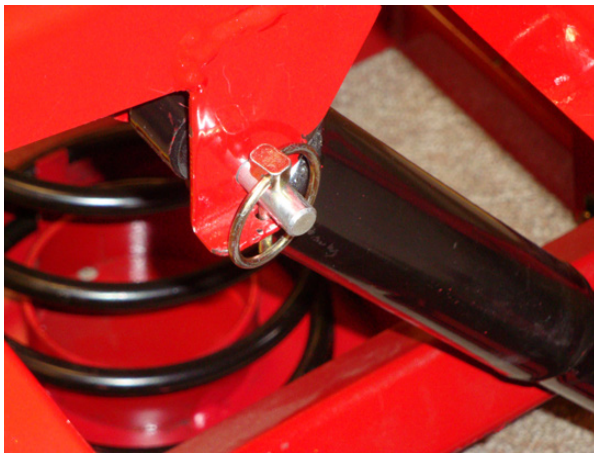

3. With two people, push down slightly on the platform to relieve pressure on the latch stops.
4. Lift the latch stops and pull up the platform until it reaches its fully raised position.

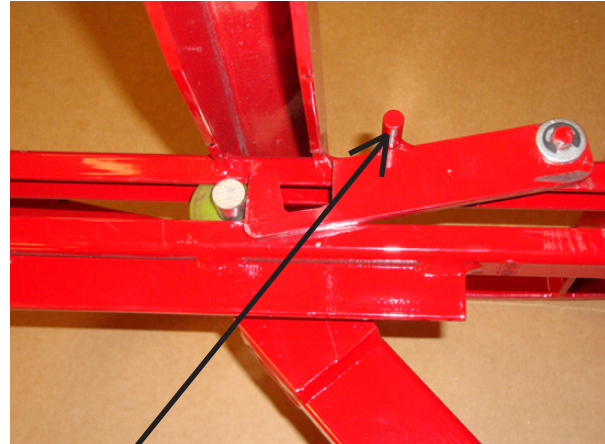

RELEASE LATCH STOP BY PULLING UP HERE (BOTH SIDES)

5. While one person holds the platform up the second person places the dampener pin into the hole in the roller track nearest to the hinge end.



6. Remove the bayonets by lifting the cliplock and turning 45 degrees CW, then turning the bayonet 45 degrees CCW and lifting out. Place the bayonets aside in a safe location.



BAYONET WITH CLIPLOCK



TO UNLOCK , LIFT CLIPLOCK



TURN CLIPLOCK 45 DEGREES CW



TURN BAYONET 45 DEGREES CCW AND LIFT TO REMOVE

7. If any secondary springs are already installed, remove them before attempting to remove the main spring.
8. Grasp the main spring by the second or third coil down from the top, compress the spring and slide the top of the spring out of the upper spring pocket and remove the spring from the frame.



9. While one person holds the platform up the second person removes the dampener pin from the hole in the roller track nearest to the hinge end.



10. With two people, lower the platform until it reaches the base.



11. Re-install the dampener pin into the bracket to prevent it from being misplaced.



12. Reinstall the yellow bayonet(s) by inserting them into the bayonet openings and turning them clockwise into the locked position. Secure with the black clip locks.

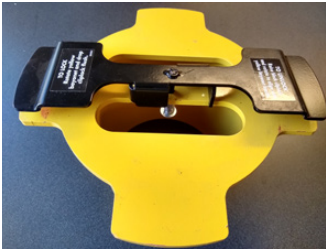

BAYONET WITH CLIPLOCK



PLACE BAYONET IN PLATFORM



TURN BAYONET 45 DEGREES CW



TURN CLIPLOCK 45 DEGREES CCW AND LOWER TO LOCK

13. Place turntable ring back on top of platform and turn to make sure it is aligned with the rollers.

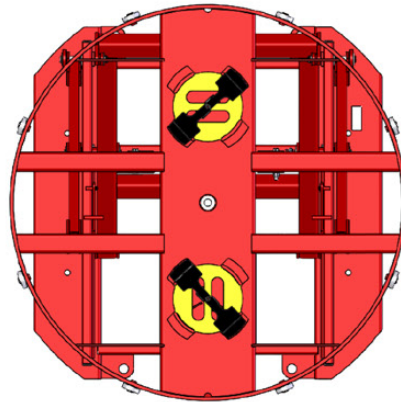
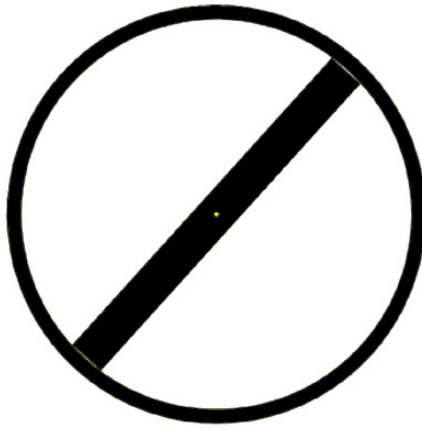

14. This procedure is now complete.

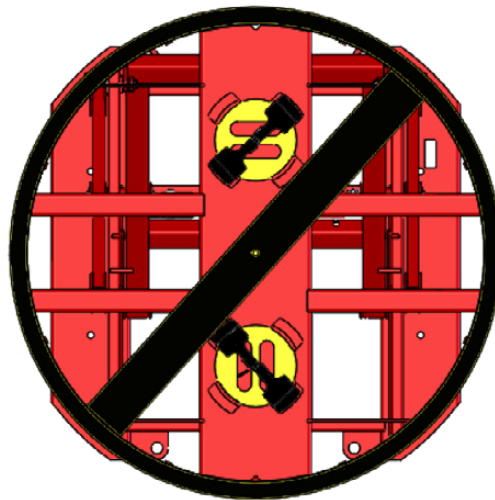

5 OPERATION

Before each use check the machine for damage or excess wear. If damage or excessive wear is found do not use the machine, contact the manufacturer for repair information and/ or replacement parts.

WARNING

Do not enter under the platform unless the platform is secured against lowering.

Do not sit, stand, or ride on the platform.

Keep hands, feet, and loose clothing away from moving parts.

Do not push/roll a load off the edge of the platform. This may cause the machine to rebound quickly and could lead to injury or damage to the machine.

The platform should always be loaded and unloaded uniformly in even layers. Uneven loading can cause the load to become unstable and could lead to injury. Uneven loading can cause premature wear or damage to the machine.

When rotating the load, do not grab the rotator ring or hands/fingers may be caught in the moving parts and you may be injured.

Do not drop load onto the platform or the machine may be damaged.

Do not use this machine with broken pallets. Boards and/or nails in broken pallets may catch on the platform frame and cause damage.

This machine is to be operated and transported on flat, level surfaces only.

Do not exceed the rated capacity.

5.1 Loading & Unloading

5.1.1 Manually

When manually loading, always load the pallet uniformly in even layers. As the pallet is loaded the platform will lower, maintaining the proper working height. Do not reach over the load. Instead rotate the load by pushing or pulling on the pallet.

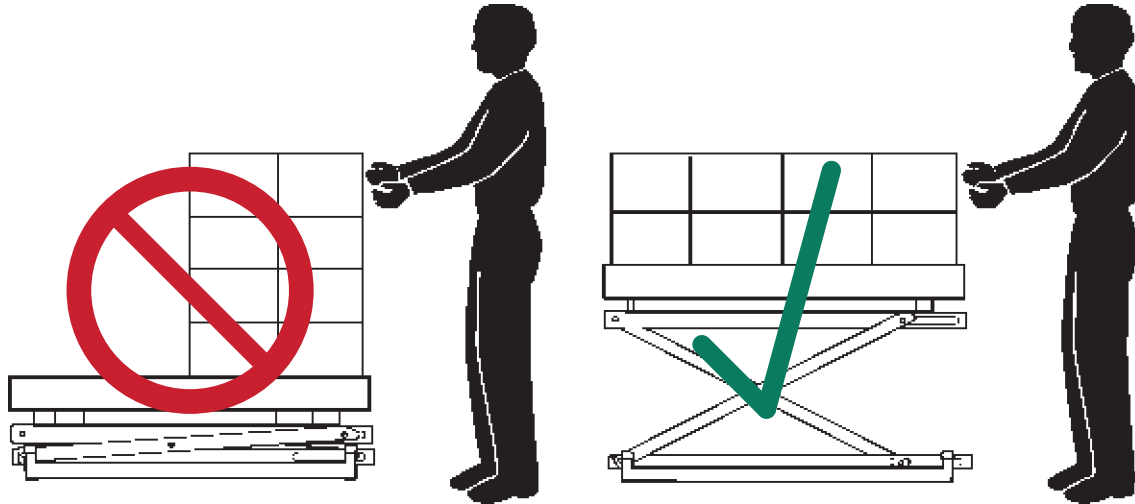

When manually unloading, always unload the pallet uniformly in even layers. As the pallet is unloaded the platform will raise, maintaining the proper working height in the ergonomic range. Do not reach over the load. Instead rotate the load by pushing or pulling on the pallet.

5.1.2 Fork Truck or Stacker

When loading with a fork truck or stacker lower the pallet onto the platform slowly until the springs are fully supporting the load or the springs are fully compressed. Only uniform loads should be placed on the platform.

When unloading with a fork truck or stacker raise the pallet off of the platform slowly until the springs are no longer supporting the load and the pallet is clear of the platform/turntable ring.

NOTICE

Do not drive the fork truck/stacker into the base frame or the machine may be damaged.

Do not slide the pallet onto/off of the platform/rotator ring or the machine may be damaged.

5.2 Transporting the Machine

⚠ WARNING

This machine may be moved while loaded. If transporting while loaded, secure both the load and turntable before moving. Unsecured loads may fall and cause death or serious injury.

If equipped with a portability kit, always ensure the floor lock is engaged before using the machine.

Do not drop the machine onto the floor or damage may occur.

The machine can be transported with or without a load on the platform. If transporting the machine with a load on the platform, always secure the load to the platform and secure the turntable from rotating unintentionally.

The machine can be transported by an appropriately rated fork truck or stacker, or by the optional portability kits.

5.2.1 Fork Truck or Stacker

Carefully insert the forks into the fork pockets on the base frame. Carefully raise the machine off of the floor and transport the machine to the desired location. Carefully lower the machine onto the floor and remove the forks from the fork pockets.

5.2.2 Portability Kit - Casters

If equipped with the caster package, always engage the floor lock before loading and unloading. Disengage the floor lock to move the machine to the desired location.



5.2.3 Portability Kit - Leveling Feet

If equipped with the leveling feet package, the machine can be raised approximately three inches to not only accommodate an uneven floor surface, but to also move the unit using manual/powered pallet jacks.

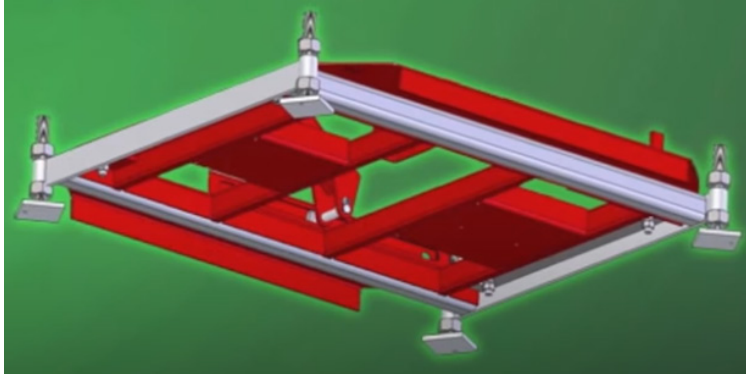

5.3 Operation Video

To supplement the instructions on the previous pages, the QR code below may be scanned to access a Presto Lifts' P3 All-Around Spring Load Leveler video illustrating loading and unloading, and the various options for enhancements, accessories and the springs being used. This video should be considered a supplement to the previous instructions, not a replacement.

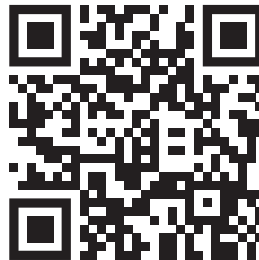

6 MAINTENANCE & REPAIR

WARNING

Do not enter under the platform unless the platform is secured against lowering.

Remove load before performing any maintenance.

Springs must be removed before performing any repair requiring disassembly of the leg set.

All inspections may be performed with the springs installed.

6.1 Maintenance Devices

This machine does not require maintenance devices, however, springs must be removed if performing any repair requiring disassembly of the leg set.

6.2 Periodic Maintenance

Before each use inspect the machine for damage or wear. If damage or wear is found remove the machine from service and repair before using.

6.2.1 Weekly

- Inspect upper and lower rollers, roller pins and bushings, and roller tracks. Replace as necessary.
- Inspect upper and lower hinge pins and bushings. Replace as necessary.
- Inspect dampener for signs of leaking and/or damage. Replace as necessary.
- Inspect center pins and bushings. Replace as necessary.
- Inspect rotator ring, rotator ring washer, and bearings. Ensure the rotator rings rotates smoothly without binding. Repair or replace bearings as necessary.
- Inspect base frame, platform, and leg set for wear or damage.

6.2.2 Semi-Annually (Every Six Months)

- Perform weekly maintenance
- Apply PTFE lubricant to all pivot points, rollers, and bearings.

6.3 Replacement Parts

Presto Lifts has carefully chosen the components in your P3 All-Around Spring Load Leveler to be the best available for the purpose. Replacement parts should be identical to the original equipment. Presto Lifts will not be responsible for equipment failures resulting from the use of incorrect replacement parts or from unauthorized modifications of the machine.

Presto Lifts offers replacement parts for your Presto Lifts machine. With your order, please include the model number and the serial number of the machine.

To order replacement parts, please call the Parts Department. See Warranty & Contact Information section.

Parts are shipped subject to the following terms:

- FOB factory
- Returns only with the approval of our parts department.
- Payment net 30 days (except parts covered by warranty).
- Freight collects (except parts covered by warranty).
- The warranty for repair parts is 30 days from date of shipment.

Parts replaced under warranty are on a “charge-credit” basis. We will invoice you when we ship the replacement part, then credit you when you return the worn or damaged part, and we verify that it is covered by our warranty. Labor is not covered under warranty for Parts orders.

7 TROUBLESHOOTING

Problem	Possible Cause	Check This
The unit lowers too easily (too early).	The spring combination may be too weak for the load.	Check the spring ratings. See Range Configurations & Spring Selections section.
The unit does not lower enough (too late).	The spring combination may be too strong for the load.	Check the spring ratings. See Range Configurations & Spring Selections section.
The top of the unit rotates away from you.	The frame of the unit may not be level.	Move the unit to a level surface or install the optional adjusting feet.
The top of the unit bounces.	The dampener may be damaged.	Check for leaks or dents. Replace if damaged.
Excessive “rumble” when the ring rotates	Wear or lack of lubrication to bearings under rotating ring.	Remove turntable, lubricate or replace bearings.
Uniform wear or metal flaking from underside of rotating ring.	Normal condition caused by work-hardening of metal.	No repair necessary. This will stop once the rotator ring wears in.

8 WARRANTY & CONTACT INFORMATION

Presto Lifts warrants this product to be free from defects in material or workmanship for the duration of the warranty period. Warranty periods vary and begin on the date of shipment. For specific warranty information, contact Presto Lifts with the machine's serial number.

Any claim for breach of this warranty must be received in writing by Presto Lifts within the warranty period. Warranties shall not cover failure or defective operation, caused by misuse, misapplication, negligence or accident, exceeding recommended capacities, or any alteration or repair of the item purchased which has not been authorized by Presto Lifts. Except as set forth herein, Presto Lifts makes no other warranties, express or implied, including THE WARRANTIES OF MERCHANTABILITY AND OF FITNESS FOR A PARTICULAR PURPOSE, all of which ARE HEREBY EXCLUDED.

Presto Lifts meets the labeling requirements of California's Proposition 65. Presto Lifts makes no warranty or representation with respect to the compliance of any product with other State or local safety or product standard codes and any failure to comply with such codes shall not be considered a defect of material or workmanship under this warranty. Presto Lifts shall not be liable for any direct or consequential damages arising out of such non-compliance.

Presto Lifts' obligations under any warranty or for any other damages which may arise under any sale, agreement, or contract, are limited to the replacement or repair of defective components at its factory or another location at Presto Lifts' discretion. This is buyer's sole remedy under any such warranty, sale, agreement, or contract. Presto Lifts will not be liable for consequential, incidental, exemplary, or punitive damages of any kind resulting from a breach of any warranty that it has provided or for breach of any term of any sale, agreement, or contract. Any warranty may be altered only in writing by Presto Lifts.

All commodities, software, or technology purchased from Presto Lifts are subject to the export and re-export control laws and regulations of the United States, including but not limited to the Export Administration Regulations ("EAR") and Department of the Treasury Office of Foreign Asset Controls ("OFAC") Regulations. Presto Lifts expects all distributors and customers to comply with these laws and regulations. Without limiting the foregoing, the distributor/customer cannot, without proper authorization from the applicable United States Government Agency, export, re-export, or transfer any commodity, software, or technology purchased from Presto Lifts, either directly or indirectly, to any entity, country, or national of any country in breach of such laws and regulations. Furthermore, Presto Lifts expects that the distributor/customer shall indemnify and hold harmless Presto Lifts from and against any claim, proceeding, action, fine, loss, cost and damages arising out of or relating to any noncompliance with export control regulations by distributor/customer, and distributor/customer are expected to compensate Presto Lifts for all losses and expenses resulting thereof, unless such noncompliance was clearly not caused by fault of the distributor/customer.

Presto Lifts Inc., 2 Hampshire Street, Suite 102, Foxborough, MA 02035
800.343.9322 | Fax: 888.788.6496
service@prestolifts.com
www.PrestoLifts.com



To view a copy of the Terms and Conditions of Sale, go to: <https://PrestoLifts.com>
(Find in About Us pull down menu)