

Presto ^{LIFTS} ECOA

Presto AX, AXR, AXS, AXT & AT Series

ECOA AL Series Scissor Lifts



Installation, Operation and Service Manual

Model Number _____

Serial # _____

Date placed in service _____

**IMPORTANT: READ CAREFULLY
BEFORE INSTALLING OR OPERATING LIFT**

Part orders are subject to a \$50 minimum charge.



NOTICE

The air actuated tilter is not shown in this manual. But, the air bag(s) fittings, connections and controls are very similar to the components used on air actuated lifts. For additional detail or related questions please contact the Presto-ECO Service Department or Parts Department at 800-343-9322.

⚠ WARNING

Cancer and Reproductive Harm -
www.P65Warnings.ca.gov

10095524

**This label (part # 10095524)
is required by California law.
For more information visit
www.P65Warnings.ca.gov.**

This manual was current at the time of printing. To obtain the latest, most updated version, please contact Presto-ECO Lifts Customer Service Department or go to our website: www.PrestoLifts.com where you will find a complete list of current owner's manuals to print.

CONTENTS

SECTION 1: Introduction	4
Responsibility of Owners and Users	5
SECTION 2: Safety	6
SECTION 3: Installation	8
A. Inspection	8
B. Installing	8
C. Pneumatics.....	9
D. Testing the Lift with No Load	9
SECTION 4: Operation	10
A. Method of Operation.....	10
B. Operation Procedures	10
SECTION 5: Maintenance	11
A. Safety Chocks	11
B. Routine Inspection and Maintenance	12
C. Troubleshooting Maintenance	12
D. Removal and Installation of Air Stroke Actuator	12
E. Removal and Installation of Hand/Foot Control.....	13
SECTION 6: Turntable	14
SECTION 7: Pneumatic Positioning Lock	14
RESTOCKING POLICY.....	22
ORDERING REPLACEMENT PARTS.....	23
WARRANTY	24

LIST OF FIGURES:

Figure 1. Lagging down lift	9
Figure 2. Maintenance Chocks.....	10
Figure 3. Pneumatic Connections	11
Figure 4. Pneumatic Connections with Lock	14
Figure 5. Pneumatic Components.....	15
Figure 6. Pneumatic Components with Turntable.....	16
Figure 8. Mechanical Components.....	18
Figure 9. Pneumatic Schematic, AX / AT	19
Figure 10. Labels and Locations	20
Figure 11. General Description AL Series.....	21

SECTION 1

INTRODUCTION

This manual attempts to provide all of the information necessary for the safe and proper installation, operation and maintenance of AX, AXR, AXS, AXT, AT and ECOAAL Scissors Lifts.

It is important that this manual be read by all personnel involved with the installation, maintenance or operation of the scissor lift. If the manual does not address an application, call your distributor or Presto-ECOALifts for assistance. Additional manuals are available upon request at www.PrestoLifts.com.

The scissor lift has a nameplate that provides the load capacity rating, serial number and model identification. Please refer to these numbers when ordering parts or requesting further information.

The AX, AXR, AXS, AXT, AT and ECOAAL Scissors Lifts are designed for lifting, lowering and positioning a wide variety of loads. **WHERE UNIQUE SITUATIONS ARISE, THAT ARE NOT COVERED IN THIS MANUAL, CALL YOUR DISTRIBUTOR OR Presto-ECOALIFTS FOR INSTRUCTIONS.**

The AX, AXR, AXS, AXT, AT and ECOAAL Scissors Lifts are designed for in-plant/non-hazardous location use only.

Responsibility of Owners and Users

Inspection and Maintenance

The device shall be inspected and maintained in proper working order in accordance with Presto-ECO's owner's manual.

Removal from Service

Any device not in safe operating condition such as, but not limited to, excessive leakage, missing rollers, pins, or fasteners, any bent or cracked structural members, cut or frayed electric, hydraulic, or pneumatic lines, damaged or malfunctioning controls or safety devices, etc. shall be removed from service until it is repaired to the original manufacturer's standards.

Repairs

All repairs shall be made by qualified personnel in conformance with Presto's instructions.

Operators

Only trained personnel and authorized personnel shall be permitted to operate these lifts.

Before Operation

Before using the device, the operator shall have:

- Read and/or had explained, and understood, the manufacturer's operating instructions and safety rules.
- Inspected the device for proper operation and condition. Any suspect item shall be carefully examined and a determination made by a qualified person as to whether it constitutes a hazard. All items not in conformance with Presto's specification shall be corrected before further use of these lifts.

During Operation

The device shall only be used in accordance with this owner's manual.

- Do not overload.
- Ensure that all safety devices are operational and in place.

Modifications or Alterations

Modifications or alterations to any Presto-ECO's industrial positioning equipment shall be made only with written permission from Presto.

SAFETY ALERT SYMBOLS AND SIGNAL WORDS

The safety of all persons operating, maintaining, repairing, or in the vicinity of this equipment is of paramount concern. This is a powerful machine with moving parts, and is capable of causing personal injury if proper precautions are not taken. Therefore, throughout this manual, certain hazards have been identified which may occur in the use of the machine, and there are appropriate instructions or precautions which should be taken to avoid these hazards. In some cases, there are consequences which may occur if instructions or precautions are not followed. Below are the symbols and signal words along with their definitions referenced from ANSI Z535.4 - Product Safety Signs and Labels.

4.11 Safety Alert Symbols: A symbol that indicates a hazard. It is composed of an equilateral triangle surrounding an exclamation mark. The safety alert symbol is only used on hazard alerting signs. It is not used on safety notice and safety instructions signs.



A): for use with DANGER signal word; (safety white triangle, safety red exclamation mark, safety red background)

B): for use with WARNING signal word; (safety black triangle, safety orange exclamation mark)

C): for use with CAUTION signal word; (safety black triangle, safety yellow exclamation mark)

D) and E): for use with DANGER, WARNING, or CAUTION signal word; (D: is a safety yellow triangle with a black border and safety black exclamation mark; E: is a safety yellow triangle with a safety black exclamation mark and a safety yellow border around a safety black band)

NOTE: D and E are provided to allow for consistency with certain ISO standards such as ISO 3864-1 and ISO 3864-2.

4.14 Signal Words: The words used in the signal word panel. The signal words for hazard alerting signs are “DANGER,” “WARNING,” and “CAUTION.” Safety notice signs use the signal word “NOTICE.” Safety instruction signs use signal words that are specific to the situation.



DANGER indicates a hazardous situation which, if not avoided, will result in death or serious injury.



WARNING indicates a hazardous situation which, if not avoided, could result in death or serious injury.



CAUTION indicates a hazardous situation which, if not avoided, could result in minor or moderate injury.



NOTICE is used to address practices not related to physical injury.



SAFETY INSTRUCTIONS (or equivalent) signs indicate specific safety-related instructions or procedures.

NOTE: DANGER, WARNING or CAUTION should not be considered for property damage accidents unless personal injury risk appropriate to these levels is involved.

SECTION 2

SAFETY

The safety of all persons installing, using, servicing, or working near the unit is of paramount concern to Presto-ECO Lifts. The lift is a powerful machine with moving parts, and is **capable of causing personal injury if proper precautions are not taken**. Therefore, throughout this manual, Presto-ECO Lifts have identified certain hazards, which may occur in the use of the unit, and provided appropriate **instructions** or precautions that should be taken to avoid these hazards. In some cases, Presto-ECO Lifts has also pointed out the **consequences** that may occur if Presto-ECO Lifts instructions or precautions are not followed. Presto-ECO Lifts use the following nationally recognized system for identifying the severity of the hazards associated with its products:

⚠ DANGER Immediate hazard that will result in severe personal injury or death.

⚠ WARNING Hazard or unsafe practice, that could result in severe personal injury or death.

⚠ CAUTION Hazard or unsafe practice, that could result in minor personal injury or property damage.

In the interest of safety, please read the entire manual carefully. You must understand the material in this manual before you install, use, or service the unit. If you have any question about any of the instructions in this manual, please contact Presto-ECO Lifts at 1-800-343-9322.

SAFETY INSTRUCTIONS

- Do not perform any repair work on a lift with a load on the platform or with the table in a raised position.
- All personnel must stand clear of the lift when the lift is in motion.
- Do not put hands or feet under lift table.
- Do not perform any repair or maintenance work with the lift in an open position without securing it first with proper maintenance devices.
- Do not stand, sit or climb on the lift at any time.
- Do not use the lift on soft, uneven or unstable surfaces.
- Do not exceed the load capacity rating on the data plate.
- Do not place a load on a moving lift.
- Do not exceed load capacity.
- Place a load in the center of the lift and be sure that the load is secured properly.

SECTION 3

INSTALLATION

A. INSPECTION

Upon receipt of the AX/AXR/AXS/AXT/AT and AL Scissor Lift, inspect the equipment completely to determine if there is any damage that occurred during shipment and that the lift is complete. **Do not** use the lift if there appears to be any damage. Check the following with the lift in the collapsed position:

1. Check for signs of damage, especially to the Airstroke Actuator™ and pneumatic components.
2. Check all connections and nuts/bolts for tightness.
3. Check base frames for flatness and for bent or damaged metal parts.

⚠ CAUTION

Do not operate the lift before performing the installation procedures specified in section B. Severe damage to the lift may occur.

B. INSTALLING

Floor Installation

- a) Make sure that the floor in the installation area is flat, stable, relatively smooth and free from dirt, obstacles or surface defects.
- b) Place the lift in the exact operating position.

⚠ CAUTION

When moving the lift *never* attempt to pick it up by the platform. The lift should be picked up only by the base frame only. The use of a spreader strap/sling is suggested. If the lift has lifting eyebolts, attach a chain spreader and raise the lift from a center position. Be sure that the eye bolts are secured in place with locking nuts prior to lifting.

- c) Make sure that the complete base of the lift is in contact with the floor. In order to provide complete contact with the floor, the base may be shimmed or grouted.

⚠ CAUTION

Do not spot shim. The complete base must be in contact with the floor or shims.

NOTICE

Machine base lag anchors need to be sized for a minimum of 5000# pull-out force for each lag.

- d) The lift frame must be anchored to the floor using four 3/4" diameter bolts, washers and nuts.
- e) Locate and lag down hand control stand or foot control so as to provide easy access. Do not obstruct the operator's work area. Make pneumatic connections according to the information contained in Section 3C.

⚠ CAUTION

Not lagging the lift base will result in structural damage to the lift.

Pit Mounted Installation

- a) Build pit to standard pit dimension as outlined in figure 2, paying careful attention to raceway, clearance and height requirements.
- b) The remaining steps are the same as required for floor installation. See section 3B.

⚠ WARNING

Do not install lifts in pits unless they have an approved bevel edge top and fully exhausting pneumatic circuit.

C. PNEUMATICS

AX/AXR/AXS/AT and AL Scissor Lifts are designed for normal factory environments. Consult the distributor for unusual applications. If your lift is equipped with a turntable positioning lock, refer to Section 6B.

⚠ CAUTION

All pneumatic connections should be performed by qualified authorized service personnel.

1. The lift requires a minimum of 80 PSI, 15 CFM, and clean dry air to function correctly.
2. Be certain that supply line is turned off and residual air has been purged from the line.
3. The lift is shipped with the control line attached to the control valve (B) and detached from the lift base. Route the control line safely to the base and make the connection (C).
4. Connect the supply line to the open port of the control valve (A).
5. Open the air supply and check the entire circuit for leaks. Secure as needed. See Fig. 3.

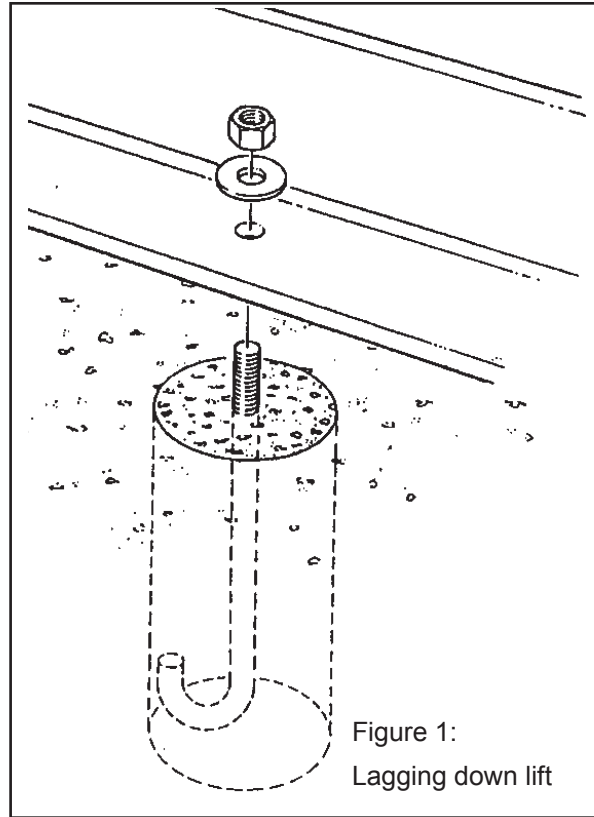

⚠ WARNING

The lift is equipped with a tamperproof pressure regulator. The regulator has been factory preset and no attempt should be made to alter the setting. Resetting of the regulator or replacement with a component not supplied by Presto-ECO Lifts will void warranty and could result in serious bodily injury.

D. TESTING THE LIFT WITH NO LOAD

1. Before testing the lift, clear the area of any loose material. Be sure the lift has no obstruction above it or on any side. Using the controls provided, briefly operate the lift (5-10 seconds). If the lift begins to rise and functions properly, continue to the full upright position.

⚠ CAUTION

If the lift does not rise immediately, or there is any operational problem, stop it immediately. Refer to the troubleshooting section and correct the problem before continuing.

2. After raising the lift completely, lower the lift completely. It should lower slowly and smoothly. If satisfied with the lift's operation, raise and lower the lift and stop at different levels in order to familiarize yourself with the lift's operation.

SECTION 4

OPERATION

A. METHOD OF OPERATION

The control valve controls the flow of air to the Air Stroke Actuator™. As the actuator is pressurized, the scissor legs are forced apart causing the tabletop to rise. As air is released from the bag, the legs collapse and the top is lowered. A factory preset flow control ensures a smooth descent at a controlled speed.

CAUTION!

Do not maintain the control valve in the open position if the lift does not move or it has reached its up or down limits. Damage to the pneumatic system may result.

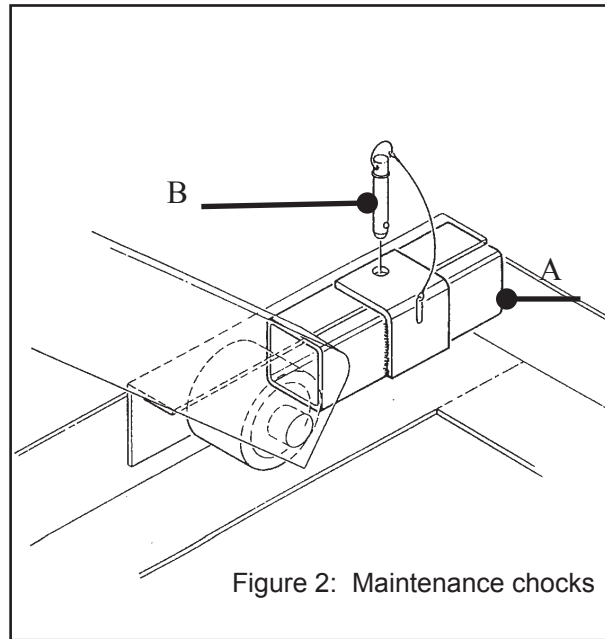

Figure 2: Maintenance chocks

B. OPERATION PROCEDURES

In order to operate the lift, follow these operating procedures:

⚠ WARNING

- a) Load the lift only in the collapsed position.
 - b) *Do not* stand, sit or climb onto the lift.
 - c) If the lift fails to move or exhibits strange movement or sound, stop immediately. *Do not* operate the lift until it has been checked and repaired.
 - d) *Do not* load or unload a moving lift.
 - e) Obey all warning labels.
1. Read and understand all the instructions before operating. If the lift has modifications or accessories, read and understand their functions.
 2. Load the lift correctly. Refer to the attached nameplate for load capacity information.
 - a) Load the lift only in the fully lowered position.
 - b) *Do not* load or unload the lift while it is moving.
 - c) *Do not* exceed the maximum rated load (note that load capacity is reduced due to side or end loading).
 - d) Place load in the center of table.
 - e) If the load is unstable or may become unstable, fasten it into position.
 3. Operate the lift.
 - a) To raise the lift, activate the hand control valve to the “up” position. Hold the valve open until the lift reaches the desired position or the lift reaches its full extension. The valve is spring-loaded and will return to center (closed) when the lever is released.
 - b) To lower the lift, activate the hand control valve to the down position. Hold the valve open until the lift descends to the desired height or the lift reaches its fully lowered position. Move the valve briefly to the up position to stop downward movement.
 4. Wait until the lift has come to a complete stop before unloading the lift.
 5. Stand clear of the lift when operating in order to avoid injury.

SECTION 5

MAINTENANCE

Generally, the AX/AXR/AXS/AXT/AT and AL Series of pneumatic scissor lifts will require little maintenance. However, routine maintenance and inspection will minimize cost of repairs and hazardous conditions.

▲WARNING

Never go under or service lift with a load on the table or with the scissor mechanism loaded. If possible, service the lift in a down position.

▲WARNING

If the pneumatic system requires repairs, shut off and lock out the air supply. Purge the system of any pressure before beginning any repairs.

A. MAINTENANCE CHOCKS

The AX, AXR, AXS, AXT, AT Series and the AL Scissors Lifts are designed to be maintained and serviced in a raised position. Maintenance chocks are provided for locking the lift in a raised position. Refer to Figure 2.

1. Chock Installation
 - a) Completely remove any load from the lift platform.
 - b) Raise the lift to its full height.
 - c) Slip the maintenance chock (A) in place and insert the locking pin (B).
 - d) Lower the lift until the leg roller comes in contact with the maintenance chock.
 - e) Check that the maintenance chock is securely in place.
 - f) Release all air pressure from the lift. The chock is now supporting the lift.
2. Chock Removal
 - a) Raise the lift to its full height.
 - b) Remove the locking pin (B) and the maintenance chock (A).
 - c) Lower the lift.

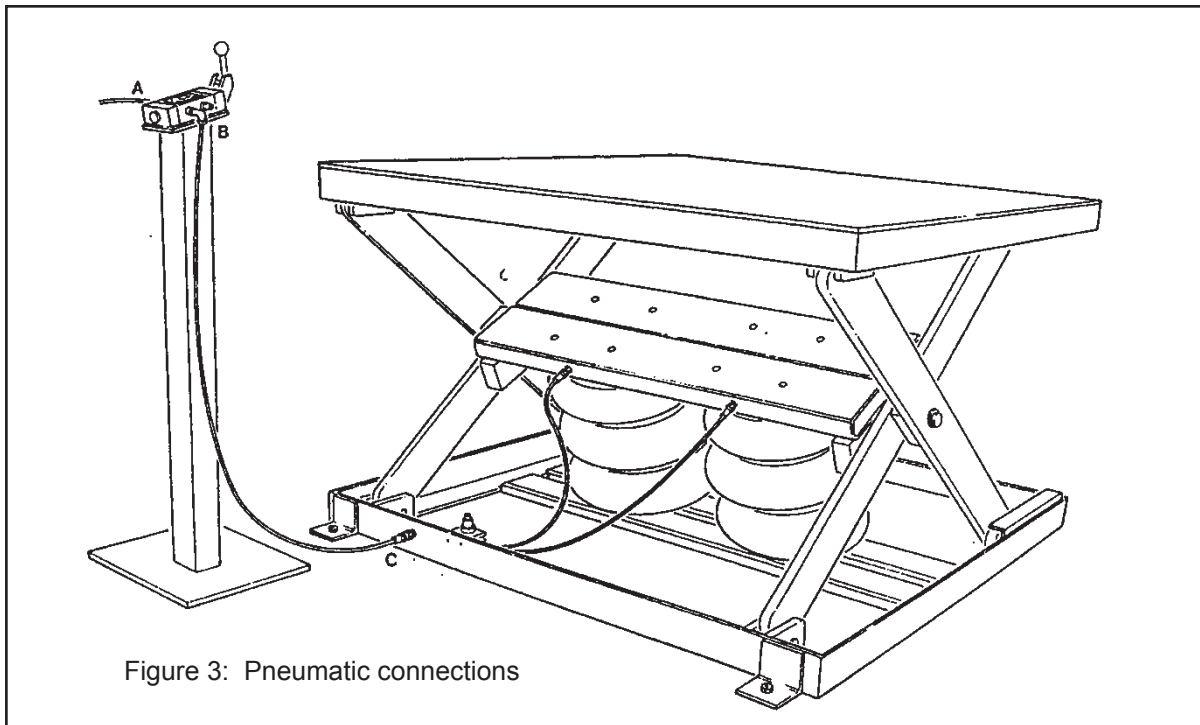

Figure 3: Pneumatic connections

B. ROUTINE INSPECTION AND MAINTENANCE

All routine inspection maintenance should be performed on a monthly basis.

⚠WARNING

Maintenance chock and pin must be installed on the lift while maintenance is being performed. Contact Presto-ECO Lifts for the recommended parts, if yellow maintenance chock is not available.

1. With the lift unloaded and its fully raised position, check the pneumatic system for leaks.

- a) Check all fittings, lines and components for escaping air.
- b) In addition to listening for an audible hissing, perform a soap bubble test.
- c) If a leak exists, repair immediately.

2. Inspect the following:

- a. Check snap ring and shield on rollers. Replace if damaged.
3. Check Air Stroke Actuator™ for any signs of wear, chafing, nicks, splits, etc. Replace as specified in Section 5 (D).
4. Check rollers for signs of wear. Replace if damaged. Clear roller track of any debris. Refer to Figure 8.
5. Check roller snap ring and shield. Replace if damaged. Refer to Figure 8.
6. Tighten all visible nuts and bolts.
7. Bearings on all lifts are permanently lubricated and *do not* require servicing.
8. Check all lag anchors to make sure they are tight.

C. TROUBLESHOOTING MAINTENANCE

All servicing should be done by qualified personnel who have read and understand all of the information provided in the Operating, Installation and Maintenance sections of this manual.

LIFT MOVING SLOWLY OR NOT AT ALL

1. Check for obstructions.
2. Check for incoming air supply. Both PSI and CFM.
3. Check circuit for air leaks, loose connection, damaged hose, etc. Listen for air escaping.
4. Is lift overloaded? Check capacity.
5. Check control valve for sticking or jamming, repair or replace.

D. REMOVAL AND INSTALLATION OF AIR STROKE ACTUATOR™

1. Chock the lift as specified and be sure air supply is locked out.
2. Remove the braided hose (20) and brass nipple (19).
3. Remove the four 3/8-16 nuts (25) with a 9/16 deep socket. The Actuator will collapse as the last nut is removed.
4. Remove the four 3/8-16 hex head bolts (22) and washers (21). The Actuator will become free of the lift and may be removed.

5. Remove the four 3/8-16 (26) hex head bolts and lock washers (23) holding the plate (28) to the Actuator.
6. Unscrew the elbow (6).
7. Finally remove the four studs (24) from the Actuator end plates.
8. Installation is the reverse of removal. Be sure to use a Teflon sealant on all pneumatic connections. Pump must be replaced.

E. REMOVAL AND INSTALLATION OF HAND/FOOT CONTROL

1. Chock the lift as specified and be sure air supply is locked out.
2. Disconnect hose (8) and supply line.
3. Remove [2] plugs (5), [1] muffler (4), elbow (6).
4. Remove (2) securing nuts/bolts and remove valve from stand if a hand valve.
5. Installation is the reverse of removal. Be sure to use Teflon sealant on all NPT pneumatic connections.

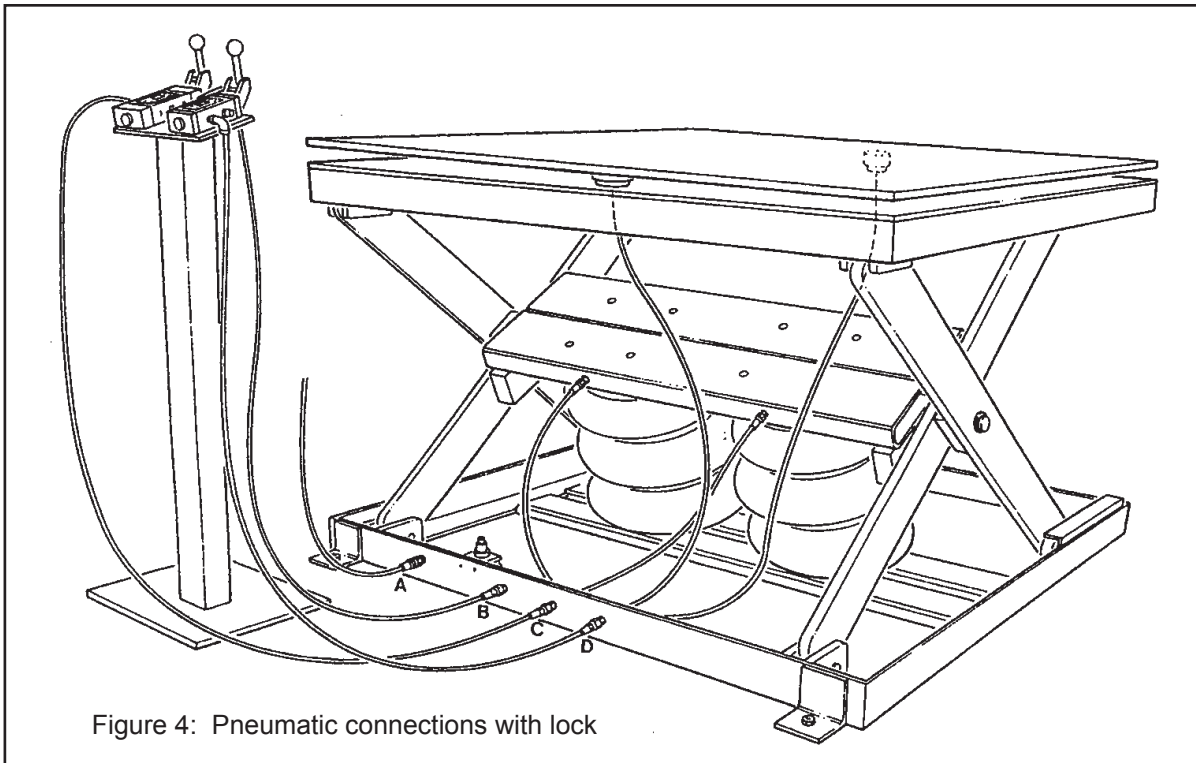

Figure 4: Pneumatic connections with lock

SECTION 6

TURNTABLE

If your lift is equipped with a rotating turntable, the following operational/ maintenance procedures apply.

A. INSPECTION

As with the basic scissor lift, inspect the unit to be sure no damage has occurred in shipment and that the unit is complete.

1. Rotate the turntable by hand to be sure the table rotates freely without binding or unusual sounds.
2. Inspect for loose/ damaged connections and nuts/bolts.

SECTION 7

PNEUMATIC ROTATIONAL POSITIONING LOCK

B. INSTALLATION (IF EQUIPPED) OF PNEUMATIC POSITIONING LOCK

The initial pneumatic connections differ from a standard lift and are specified below. All other installation, safety and use instructions should be observed. Refer to schematic Fig. 8 and Fig. 9.

1. Connect incoming air supply to inlet (A).
2. Connect supply line (B).
3. Connect control line (C) lifting.
4. Connect control line (D) lock.

Positioning Lock:

The lock is designed for holding the turntable in place; it is not designed to stop or brake a rotating load.

1. Manually rotate the turntable to the desired position.
2. With the turntable at rest, activate the lock control valve to the "on" position. This will lock the table in place.
3. Moving the control valve to "off" will release the lock and allow the turntable to rotate.

Pneumatic Components Replacement List

(Refer to Figure 5)

Location	Description	AX10	AX20	AX40
1	Pneumatic Valve	1	1	1
2	Nameplate	1	1	1
3	Screw	2	2	2
4	Muffler	2	2	2
5	Plug-Oil Tank	2	2	2
6	Elbow, Street	3	3	4
7	Fitting	2	2	2
8	Hose	1	1	1
9	Elbow	1	1	1
10	Nipple, Brass	1	1	1
11	Regulator	1	1	1
12	Screw	2	2	2
13	Nut, Machine	2	2	2

Location	Description	AX10	AX20	AX40
14, 17	Nipple, Brass	1	1	1
15	Reducer	2	2	3
16	Quick Exhaust	1	1	1
18	Tee Female	-	-	1
19	3" Brass Nipple	-	1	2
20	SS Hose Assy.	1	1	2
23	Washer, Lock	8	8	16
24	Screw	4	4	8
25	Nut, Self Lock	4	4	8
26	Screw 3/8" - 16x	8	8	16
27	Airstroke Actuator	-	1	2
27	Airstroke Actuator	1	-	-
28	Sub Plate Air	1	1	2

Call Parts Department with model and serial number to receive a quotation.

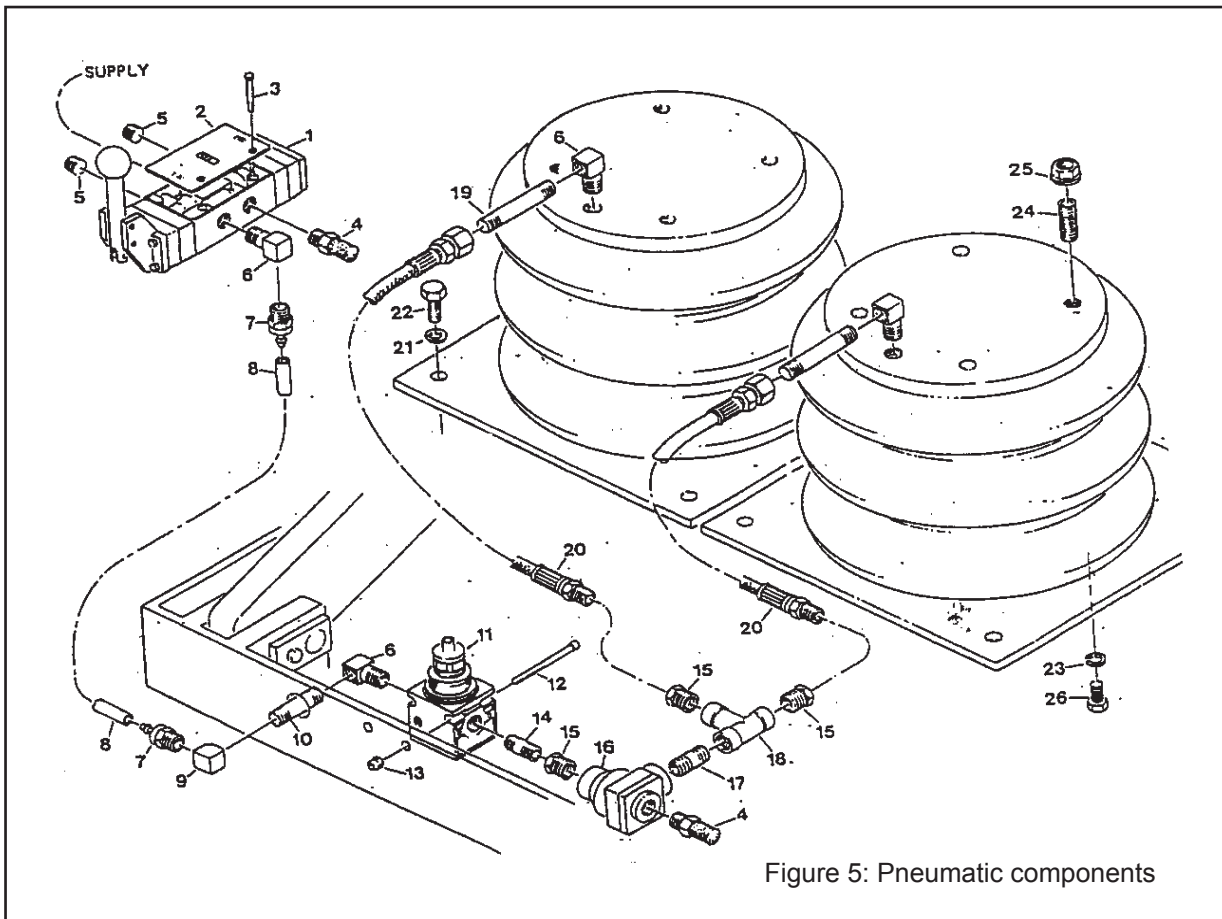

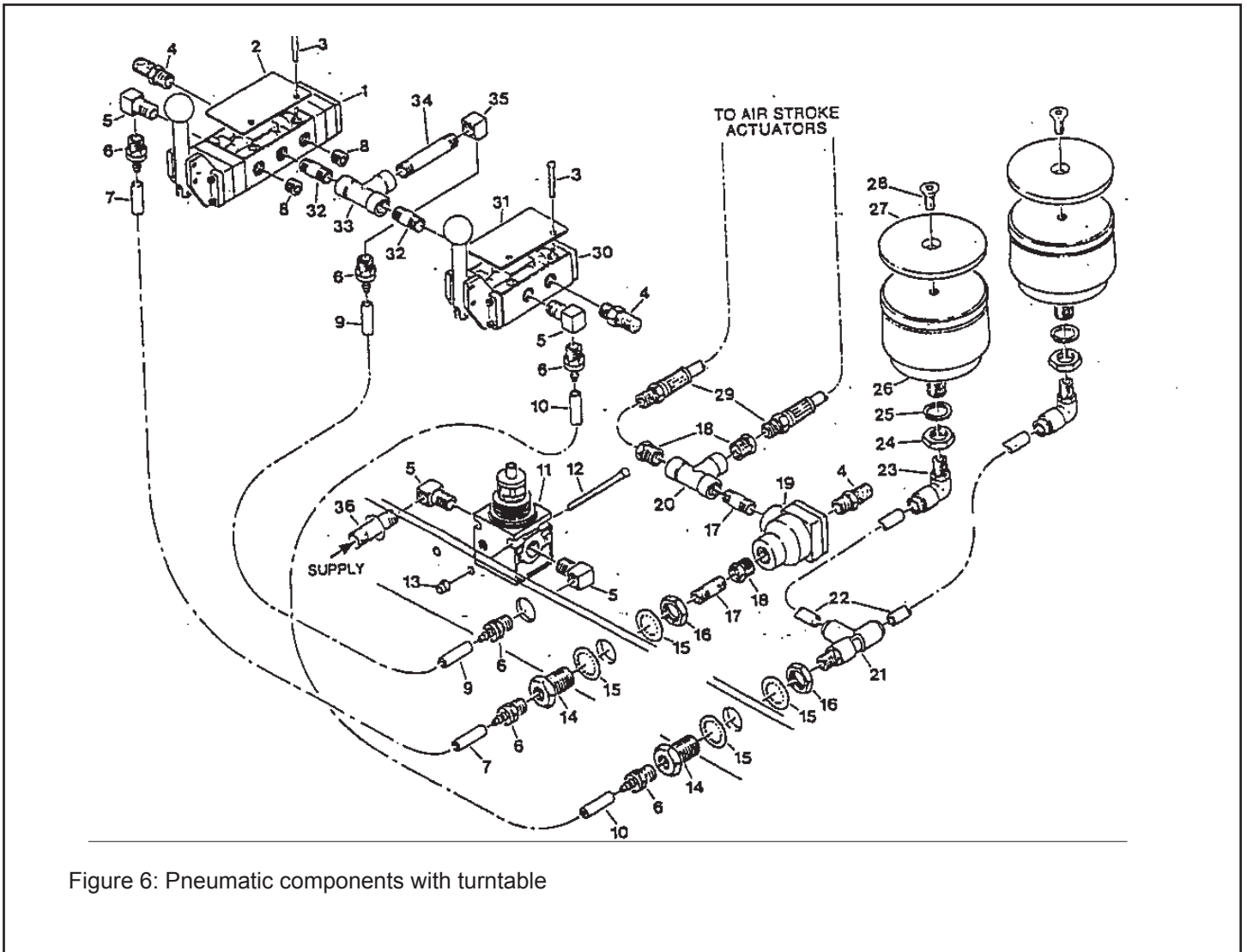

Figure 6: Pneumatic components with turntable

Turntable Positioning Lock Components Replacement List

(Refer to Figure 6)

Location	Description	AXR10	AXR20	ARX40
1	Pneumatic Valve	1	1	1
2	Nameplate	1	1	1
3	Screw	2	2	2
4	Muffler	2	2	2
5	Elbow, Street	3	3	4
6	Fitting	2	2	2
7	Hose	1	1	1
8	Plug	2	2	2
10	Hose	1	1	1
11	Regulator	1	1	1
12	Screw	2	2	2
13	Nut, Machine	2	2	2
14	Bulkhead Fitting	2	2	2
15	Bulkhead Fitting	4	4	4
16	Bulkhead Fitting	2	2	2
17	Brass Nipple 3/8"	1	1	1
18	Reducer	2	2	3
19	Quick Exhaust	1	1	1
20	Female Fitting 3/8"	1	1	2
21	Tee Male	1	1	1
22	Tubing	2	2	2
23	Elbow, 90 degree	2	2	2
24	Nut, 5/8"	2	2	2
25	Washer, Lock	2	2	2
26	Air Positioner	2	2	2
27	Pad Positioning	2	2	2
28	Screw	2	2	2
29	SS Hose Assembly	1	1	1
30	Valve, Hand 2 Pts.	1	1	1
31	Nameplate	1	1	1
32	Brass Nipple 1/4"	2	2	2
33	Female Tee 1/4"	1	1	1
35	El-Female	1	1	1
36	Brass Nipple	2	2	2

Call Parts Department with model and serial number to receive a quotation.

Mechanical Components Replacement List

(Refer to Figure 8)

Location	Description	AXR10	AXR20	ARX40
1	Pin Retain Assembly	4	4	4
2	Screw 1/4"	4	4	4
3	Washer, Lock	4	4	4
4	Ring, External	4	4	4
5	Spacer	2	2	2
6	Retaining Ring	2	2	2
7	Roller	4	4	4
8	Washer, 1" ID	4	4	4
9	Rings, Lock	1	1	1
10	Bearing, Radial	1	1	1
11	Bronz, Center	1	1	1
12	Screw, Shoulder	1	1	1

Call Parts Department with model and serial number to receive a quotation.

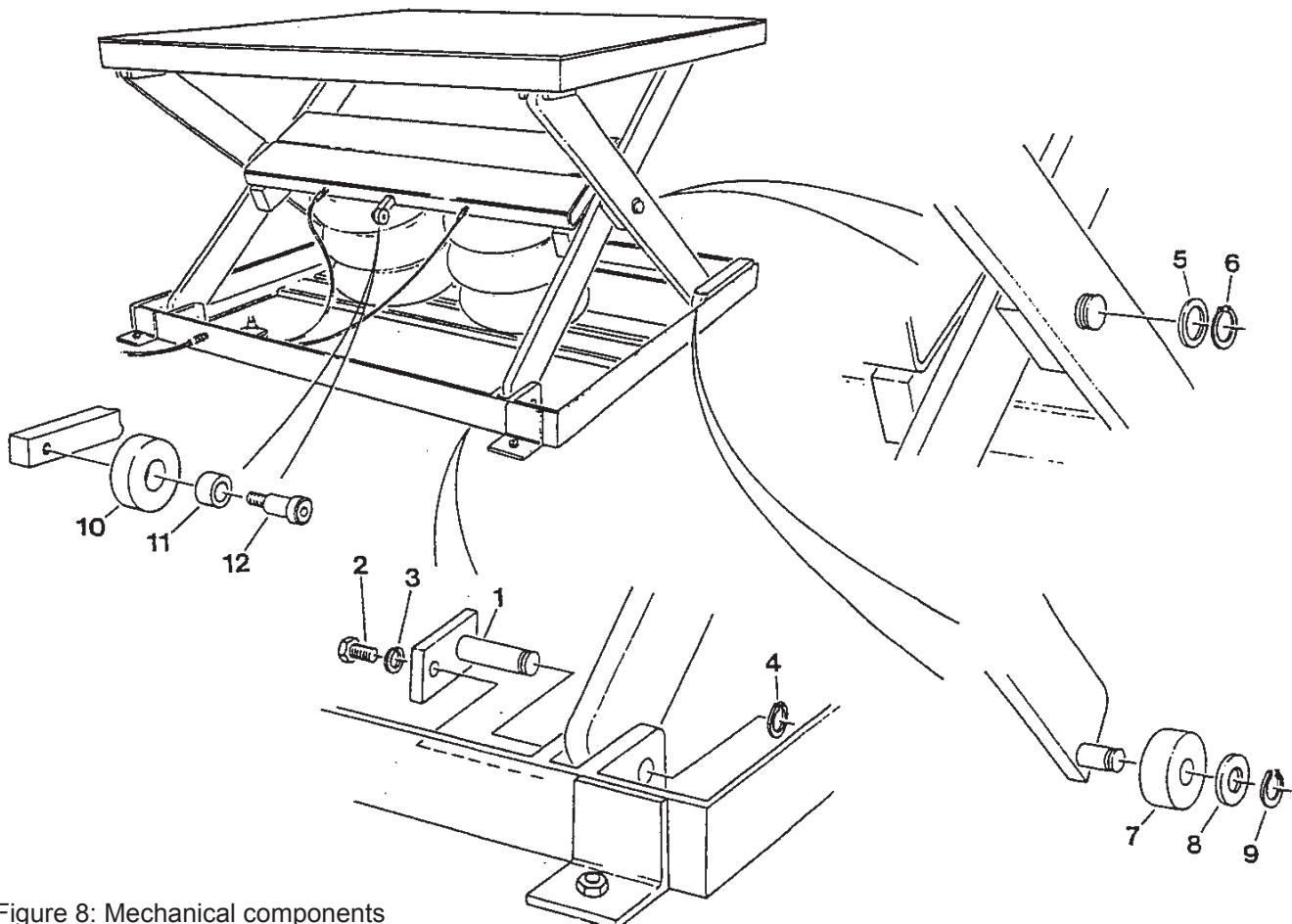

Figure 8: Mechanical components

Figure 9: Pneumatic schematic AX / AT

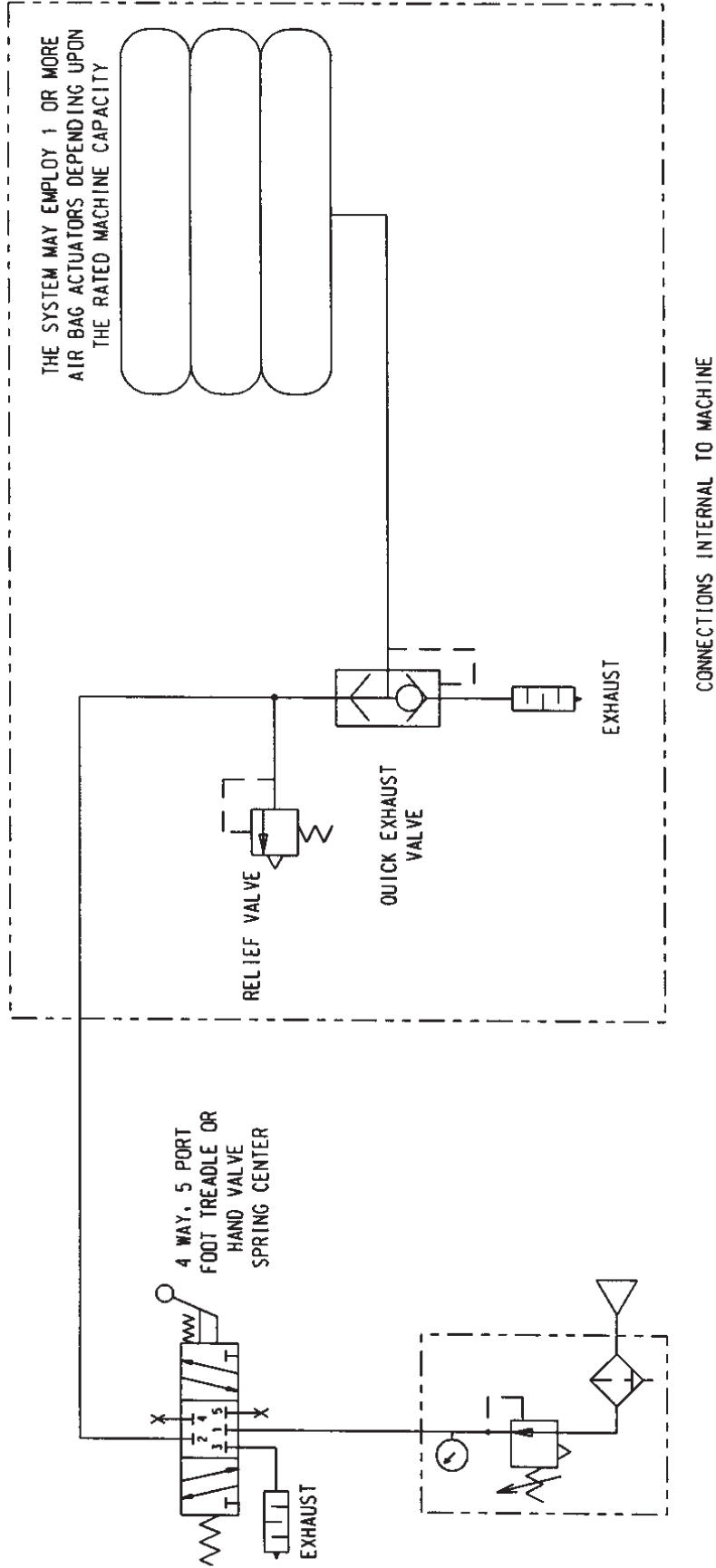

Figure 10. Labels and Locations

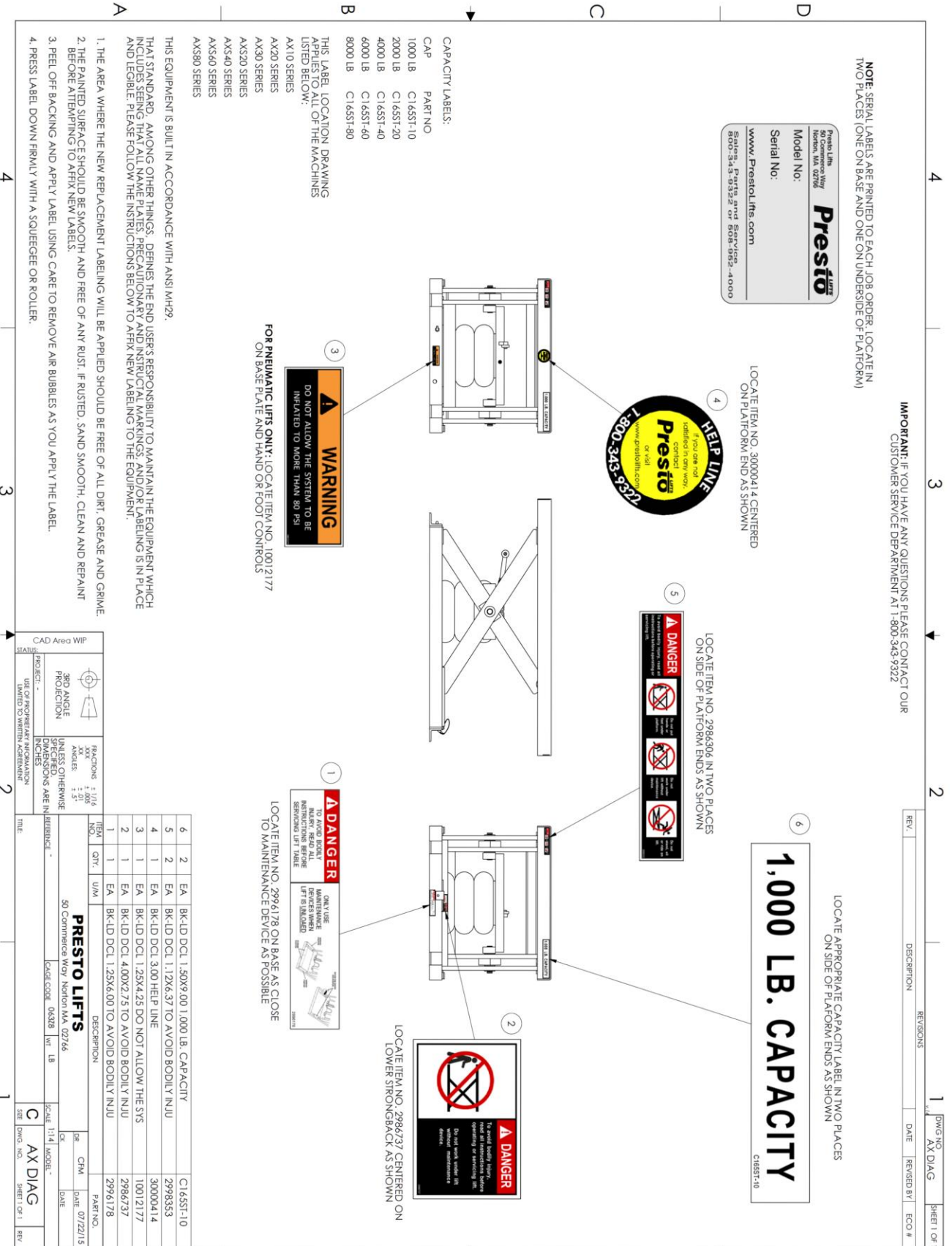
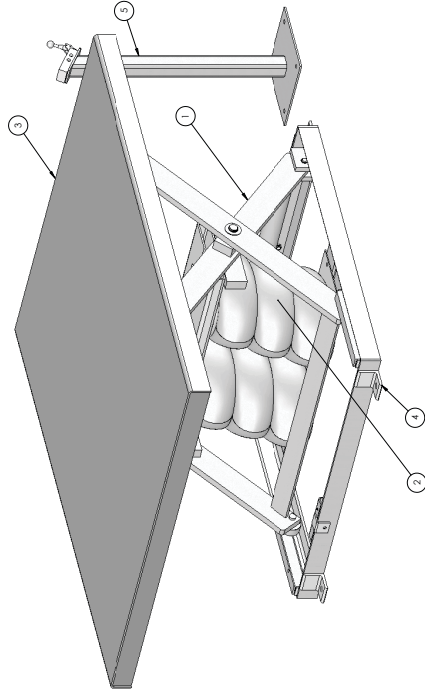
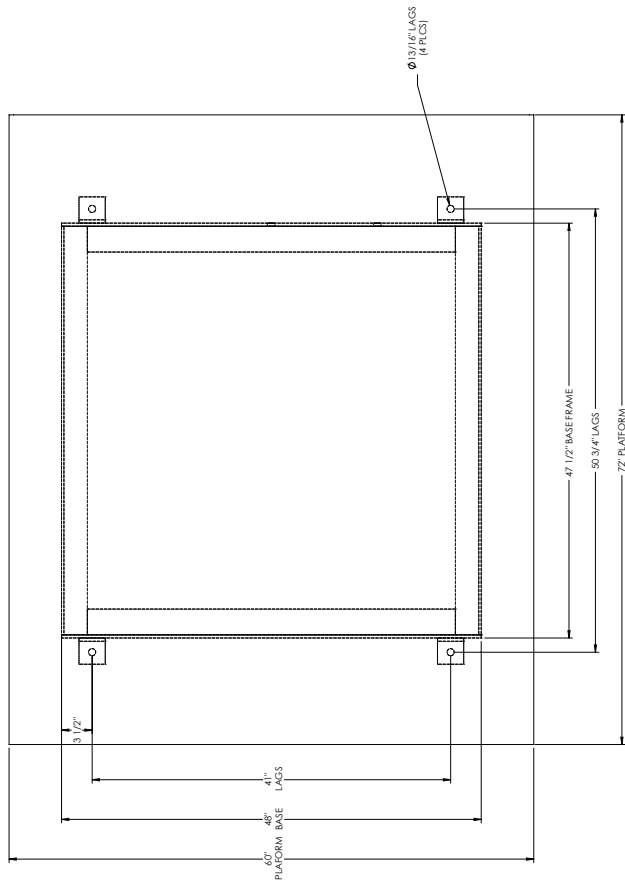

Figure 11: AL- General Description



GENERAL DESCRIPTION
 MODEL: AL-040-24-60072
 CAPACITY: 4000 LBS. UNIFORM LOAD
 POWER: AIR 80 PS @ 15 CFM
 CONTROLS: FESTO AIR MOUNTED HAND VALVE
 FINISH: ECOA YELLOW AND ECOA LABELS

NOTES:
 1. AL UNITS ARE DESIGNED FOR STATIONARY USE AND MUST BE LAGGED TO THE FLOOR.

QTY	UNIT	DESCRIPTION	PART NO.
1	EA	BA BAL ASST AX40 48.00X48.00	82001910
2	EA	PH AB ACTR ASSY AX40	82001913
4	EA	TR PE WGT PLATE 0007200 STR 24X40	82001901
3	EA	TR PE WGT PLATE 0007200 STR 18X40	82001900
1	EA	PH AND CTRL STA 25	82001900
1	EA	PH AIR SCHEMATIC AVAT	10164998
1	EA	CFC SHW YEL ECOA	10085891

PRESTO LIFTS / ECOA INC.	
ADDRESS	30 Commerce Way, North MA 02746
PHONE	603-888-0039
TELEFAX	603-888-0038
EMAIL	SALES@PRESTOLIFTS.COM
WEBSITE	WWW.PRESTOLIFTS.COM
DATE	12/07/16
REV	1
BY	DAK
CHECKED	DAK
APPROVED	DAK
TITLE	AL-040-24-60072 60X72 ECOA YELLOW
SHEET NO.	D
TOTAL SHEETS	5007379
SCALE	AS SHOWN

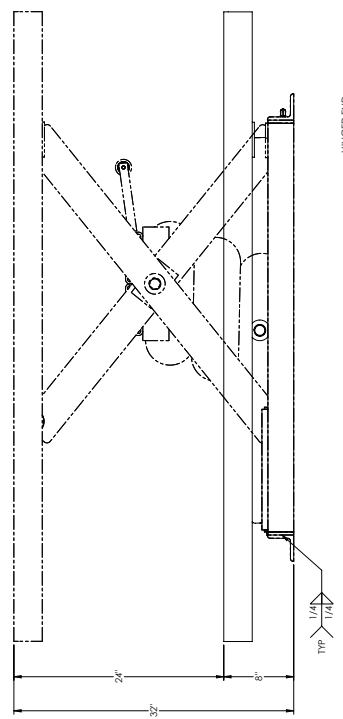

PARTS

Standard parts may be returned with a 20% restocking fee or \$35.00 net, whichever is greater. Modified or custom-engineered parts are not returnable. Unfortunately, due to potentially concealed damage, all sales of electrical assemblies are final.

QUALITY ISSUES

Should you feel there is a quality problem, please contact the seller to ask questions and gather information on how to rectify the issue. Presto-ECO Lift reserves the right to determine potential credits, as a result of factory defects, based on its inspection of the merchandise.

GENERAL

All products shipped from our factory have passed Quality Assurance inspection and testing. The carrier of choice has signed for, and accepted the product in new working condition. The customer should inspect to ensure it is not received damaged, has no concealed damage or is not incomplete. Parts orders are determined to be complete based upon Presto-ECO inspection sheets and carrier shipping weights.

Ordering Replacement Parts

Presto-ECOALifts has carefully chosen the components in your unit to be the best available for the purpose. Replacement parts should be identical to the original equipment. Presto-ECOALifts will not be responsible for equipment failures resulting from the use of incorrect replacement parts or from unauthorized modifications to the unit.

Presto-ECOALifts can supply all replacement parts for your lift. With your order, please include the model number and the serial number of the unit. You can find these numbers on the name plate. This plate is located within the scissors mechanism.

To order replacement parts, please call the Presto-ECOALifts Parts Department. Parts are shipped subject to the following terms:

- FOB factory
- Returns only with the approval of our parts department.
- Credit cards preferred (except parts covered by warranty).
- Freight collect for truck (except parts covered by warranty).
- Freight – prepaid and invoice for small parcel shipments (except parts covered by warranty).
- The warranty for repair parts is 30 days from date of shipment.

Parts replaced under warranty are on a “charge-credit” basis. We will invoice you when we ship the replacement part, then credit you when you return the worn or damaged part, and we verify that it is covered by our warranty. Labor is not covered under warranty for Parts orders.

Presto-ECOALifts Parts Department

50 Commerce Way, Norton, MA 02766

Telephone: 800-343-9322

FAX: 888-788-6496

Email: service@PrestoLifts.com

www.PrestoLifts.com

www.ECOALifts.com

Presto-ECO Lifts Limited Warranty Policy

Presto-ECO Lifts warrants this product to be free from defects in material or workmanship for the duration of the warranty period. Warranty periods vary and begin on the date of shipment. For specific warranty information, contact Presto-ECO Lifts with the machine's serial number.

Any claim for breach of this warranty must be received in writing by Presto-ECO Lifts within the warranty period. Warranties shall not cover failure or defective operation, caused by misuse, misapplication, negligence or accident, exceeding recommended capacities, or any alteration or repair of the item purchased which has not been authorized by Presto-ECO Lifts. Except as set forth herein, Presto-ECO Lifts makes no other warranties, express or implied, including THE WARRANTIES OF MERCHANTABILITY AND OF FITNESS FOR A PARTICULAR PURPOSE, all of which ARE HEREBY EXCLUDED.

Presto-ECO Lifts meets the labeling requirements of California's Proposition 65. Presto-ECO Lifts makes no warranty or representation with respect to the compliance of any product with other State or local safety or product standard codes and any failure to comply with such codes shall not be considered a defect of material or workmanship under this warranty. Presto Lifts shall not be liable for any direct or consequential damages arising out of such non-compliance.

Presto-ECO Lifts' obligations under any warranty or for any other damages which may arise under any sale, agreement, or contract, are limited to the replacement or repair of defective components at its factory or another location at Presto-ECO Lifts' discretion. This is buyer's sole remedy under any such warranty, sale, agreement, or contract. Presto-ECO Lifts will not be liable for consequential, incidental, exemplary, or punitive damages of any kind resulting from a breach of any warranty that it has provided or for breach of any term of any sale, agreement, or contract. Any warranty may be altered only in writing by Presto-ECO Lifts.

All commodities, software, or technology purchased from Presto-ECO Lifts are subject to the export and re-export control laws and regulations of the United States, including but not limited to the Export Administration Regulations ("EAR") and Department of the Treasury Office of Foreign Asset Controls ("OFAC") Regulations. Presto Lifts expects all distributors and customers to comply with these laws and regulations. Without limiting the foregoing, the distributor/customer cannot, without proper authorization from the applicable United States Government Agency, export, re-export, or transfer any commodity, software, or technology purchased from Presto-ECO Lifts, either directly or indirectly, to any entity, country, or national of any country in breach of such laws and regulations. Furthermore, Presto-ECO Lifts expects that the distributor/customer shall indemnify and hold harmless Presto-ECO Lifts from and against any claim, proceeding, action, fine, loss, cost and damages arising out of or relating to any noncompliance with export control regulations by distributor/customer, and distributor/customer are expected to compensate Presto-ECO Lifts for all losses and expenses resulting thereof, unless such noncompliance was clearly not caused by fault of the distributor/customer.