

ECOA HH SERIES



Installation, Operation and Service Manual

Model Number _____

Serial # _____

Date placed in service _____

**IMPORTANT: READ CAREFULLY
BEFORE INSTALLING OR OPERATING LIFT**

Part orders are subject to a \$50 minimum charge.



This manual was current at the time of printing. To obtain the latest, most updated version, please contact Presto-ECO Customer Service Department at 1-800-454-7159.

CONTENTS

INTRODUCTION	4
RESPONSIBILITY OF OWNERS AND USERS	5
SAFETY ALERT SYMBOLS AND SIGNAL WORDS.....	6
SAFETY PRECAUTIONS.....	7
FUNCTIONAL DESCRIPTIONS.....	9
INSTALLATION INSTRUCTIONS	11
OPERATING INSTRUCTIONS	13
ROUTINE MAINTENANCE	14
OPERATION	15
ELECTRICAL SECTION	18
TROUBLESHOOTING	22
LIMITED WARRANTY.....	24

List of Figures

Figure 1	Safety Warning Label Locations	8
Figure 2	Safe Servicing of the Lift	10
Figure 3	General Layout of the HH Series Lift	12
Figure 4	Optional Limit Switch Assembly	16
Figure 5	Hydraulic Schematic for Standard HH Lift	17
Figure 9	Electrical Schematic for 230V/1ph/60Hz Supply	18
Figure 10	Electrical Schematic for 208-230V/3ph/60Hz.....	19
Figure 13	Exploded front view of HLT/HH Series	20
Figure 14	Exploded back view of HLT/HH Series.....	21

Tables

Table 1	Hydraulic Oil Specifications	15
---------	------------------------------------	----

INTRODUCTION

This manual attempts to provide all of the information necessary for the safe and proper installation, operation and maintenance of lifts. It is important that all personnel involved with the installation, maintenance or operation of the scissor lift read this manual.

Where unique situations arise, that are not covered in this manual, call Presto-ECO for further instructions at 1-800-454-7159.

The lift has a nameplate that provides the load capacity ratings, serial number and model identifications. Please refer to these numbers when ordering parts or requesting further information.

The lifts are designed for lifting, lowering and positioning a variety of loads. WHERE UNIQUE SITUATIONS ARISE, THAT ARE NOT COVERED IN THIS MANUAL, CALL Presto-ECO FOR FURTHER INSTRUCTIONS.

The lifts are designed for inplant/nonhazardous location use only. These units are not for personnel lifting.

GETTING STARTED

PLEASE READ THE INSTALLATION INSTRUCTIONS CAREFULLY BEFORE INSTALLING, USING OR SERVICING THE HH SERIES INDUSTRIAL LIFT. The safety of all persons installing, using or servicing the HH Series Industrial Lift is of utmost importance to Presto-ECO. The HH Series Industrial Lift is capable of supporting heavy loads and is capable of causing SEVERE PERSONAL INJURY if used improperly or certain safety precautions are not taken. When properly used and maintained, the HH Series Industrial Lift will provide many years of safe, trouble free service. If you have any questions about any of the instructions in this manual or about the use of this product, PLEASE contact your DEALER or Presto-ECO.

HH is the model designation for the HLT Heavy Duty Series Industrial Lift. Presto-ECO's HLT Heavy Duty Series lifts have been re-designed, and re-designated as the HH series.

Throughout this service manual the HH Series Industrial Lift may be referred to as the "HH", "HLT", the "industrial lift" or the "lift".

INSPECTION

IMMEDIATELY upon receipt of the HH Series Industrial Lift, remove all packing and strapping material and visually inspect the unit for damage. Any damage to the lift MUST BE NOTED on the delivery receipt. After the preliminary inspection is conducted, the lift should be thoroughly inspected for any concealed damage that was not readily apparent during the preliminary inspection. Any concealed damage found that was not noted on the delivery receipt should be IMMEDIATELY reported in writing TO THE DELIVERING CARRIER.

Responsibility of Owners and Users

Inspection and Maintenance

The device shall be inspected and maintained in proper working order in accordance with this Presto-ECO A owner's manual.

Removal from Service

Any device not in safe operating condition such as, but not limited to, excessive leakage, missing rollers, pins, or fasteners, any bent or cracked structural members, cut or frayed electric, hydraulic, or pneumatic lines, damaged or malfunctioning controls or safety devices, etc. shall be removed from service until it is repaired to the original manufacturer's standards.

Repairs

All repairs shall be made by qualified personnel in conformance with Presto-ECO A's instructions.

Operators

Only trained personnel and authorized personnel shall be permitted to operate these lifts.

Before Operation

Before using the device, the operator shall have:

- Read and/or had explained, and understood, the manufacturer's operating instructions and safety rules.
- Inspected the device for proper operation and condition. Any suspect item shall be carefully examined and a determination made by a qualified person as to whether it constitutes a hazard. All items not in conformance with Presto-ECO A's specification shall be corrected before further use of these lifts.

During Operation

The device shall only be used in accordance with this owner's manual.

- Do not overload.
- Ensure that all safety devices are operational and in place.

Modifications or Alterations

Modifications or alterations to any Presto-ECO A industrial positioning equipment shall be made only with written permission from Presto-ECO A.

SAFETY ALERT SYMBOLS AND SIGNAL WORDS

The safety of all persons operating, maintaining, repairing, or in the vicinity of this equipment is of paramount concern. This is a powerful machine with moving parts, and is capable of causing personal injury if proper precautions are not taken. Therefore, throughout this manual, certain hazards have been identified which may occur in the use of the machine, and there are appropriate instructions or precautions which should be taken to avoid these hazards. In some cases, there are consequences which may occur if instructions or precautions are not followed. Below are the symbols and signal words along with their definitions referenced from ANSI Z535.4 - Product Safety Signs and Labels.

4.11 Safety Alert Symbols: A symbol that indicates a hazard. It is composed of an equilateral triangle surrounding an exclamation mark. The safety alert symbol is only used on hazard alerting signs. It is not used on safety notice and safety instructions signs.



A): for use with DANGER signal word; (safety white triangle, safety red exclamation mark, safety red background)

B): for use with WARNING signal word; (safety black triangle, safety orange exclamation mark)

C): for use with CAUTION signal word; (safety black triangle, safety yellow exclamation mark)

D) and E): for use with DANGER, WARNING, or CAUTION signal word; (D: is a safety yellow triangle with a black border and safety black exclamation mark; E: is a safety yellow triangle with a safety black exclamation mark and a safety yellow border around a safety black band)

NOTE: D and E are provided to allow for consistency with certain ISO standards such as ISO 3864-1 and ISO 3864-2.

4.14 Signal Words: The words used in the signal word panel. The signal words for hazard alerting signs are “DANGER,” “WARNING,” and “CAUTION.” Safety notice signs use the signal word “NOTICE.” Safety instruction signs use signal words that are specific to the situation.



DANGER indicates a hazardous situation which, if not avoided, will result in death or serious injury.



WARNING indicates a hazardous situation which, if not avoided, could result in death or serious injury.



CAUTION indicates a hazardous situation which, if not avoided, could result in minor or moderate injury.



NOTICE is used to address practices not related to physical injury.



SAFETY INSTRUCTIONS (or equivalent) signs indicate specific safety-related instructions or procedures.

NOTE: DANGER, WARNING or CAUTION should not be considered for property damage accidents unless personal injury risk appropriate to these levels is involved.

SECTION 2

SAFETY

The safety of all persons installing, using, servicing, or working near the unit is of paramount concern to Presto-ECO. The lift is a powerful machine with moving parts, and is **capable of causing personal injury if proper precautions are not taken**. Therefore, throughout this manual, Presto-ECO have identified certain hazards, which may occur in the use of the unit, and provided appropriate **instructions** or precautions that should be taken to avoid these hazards. In some cases, Presto-ECO has also pointed out the **consequences** that may occur if Presto-ECO instructions or precautions are not followed. Presto-ECO use the following nationally recognized system for identifying the severity of the hazards associated with its products:

▲ DANGER Immediate hazard that will result in severe personal injury or death.

▲ WARNING Hazard or unsafe practice, that could result in severe personal injury or death.

▲ CAUTION Hazard or unsafe practice, that could result in minor personal injury or property damage.

In the interest of safety, please read the entire manual carefully. You must understand the material in this manual before you install, use, or service the unit. If you have any question about any of the instructions in this manual, please contact Presto-ECO at 1-800-343-9322.

SAFETY INSTRUCTIONS

- Do not perform any repair work on a lift with a load on the platform or with the table in a raised position.
- All personnel must stand clear of the lift when the lift is in motion.
- Do not put hands or feet under lift table.
- Do not perform any repair or maintenance work with the lift in an open position without securing it first with proper maintenance devices.
- Do not stand, sit or climb on the lift at any time.
- Do not use the lift on soft, uneven or unstable surfaces.
- Do not exceed the load capacity rating on the data plate.
- Do not place a load on a moving lift.
- Do not exceed load capacity.
- Place a load in the center of the lift and be sure that the load is secured properly.

FIGURE 1: Safety Warning Label Locations

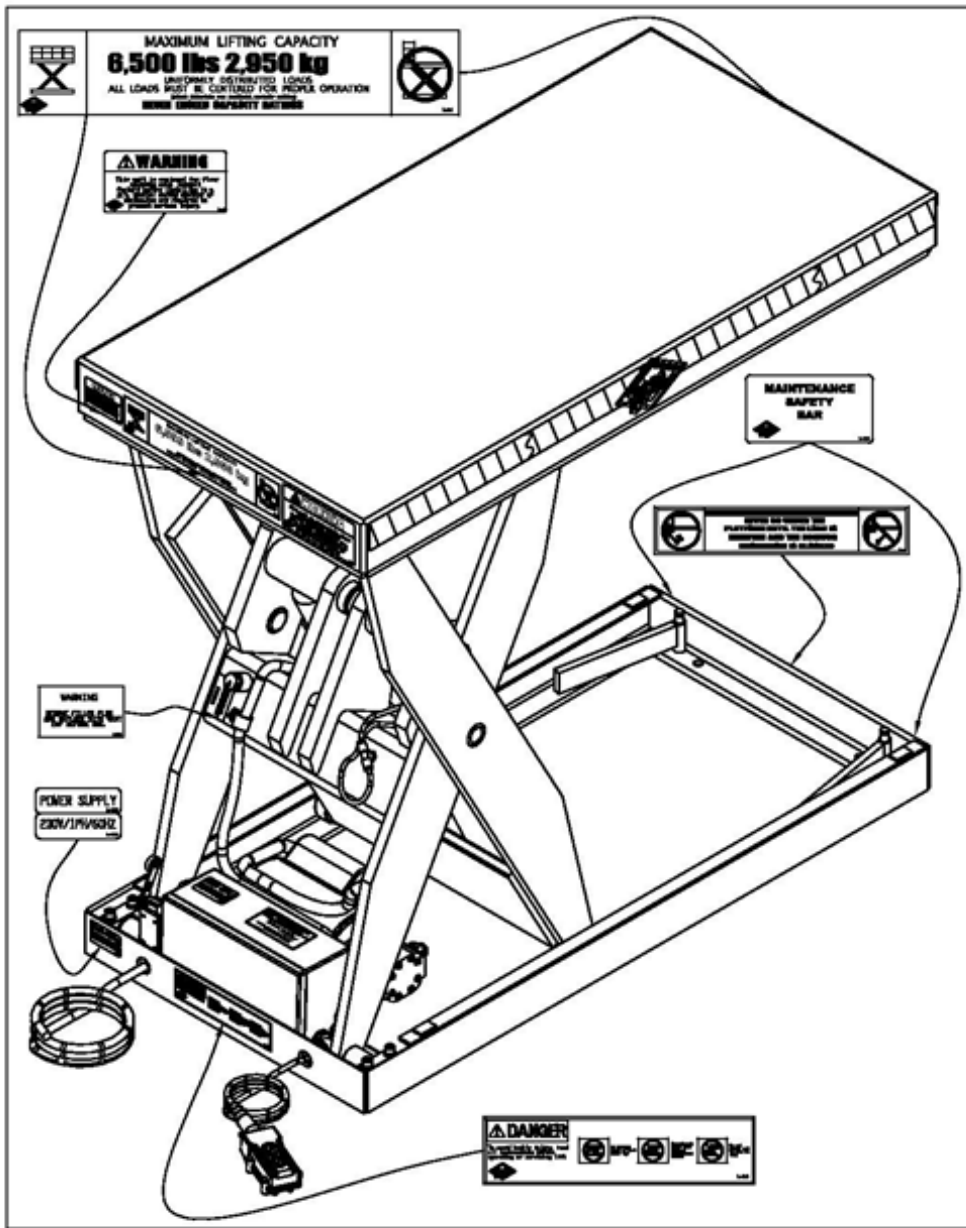

FUNCTIONAL DESCRIPTION

A general layout for an HH series surface mounted lift is shown in Figure 3.

The HH series of lifts have been primarily designed for industrial, ergonomic assistance applications. The most important advantage of the HH is that it is finitely adjustable in height. The installation of this lift provides full flexibility, allowing lifting and accurate positioning of the load anywhere within the lift's travel range.

HH industrial lifts are available in 8000 lb, 10000 lb, and 12000 lb models. 36", 48", and 60" vertical travels are available.

HH lifts have base frame widths of 35 ½", platform widths of 36" -48", and platform lengths of 48" – 102".

Depressing the "UP" control actuates the hydraulic power unit, and pumps hydraulic fluid to the piston side of the hydraulic cylinder(s). The cylinder rod extends, and opens the scissor leg assembly, raising the platform.

Depressing the "DN" control opens a solenoid valve within the power unit, which allows hydraulic fluid to flow back to reservoir. A pressure compensated flow control valve controls the lowering speed.

SCISSOR BLOCKING INSTRUCTIONS

To Engage the Maintenance Bars – see Figure 2

1. Remove all loads from the platform and depress the "up" button to raise the HH to its fully raised position.
2. Rotate each maintenance bar until it contacts the inside of the roller channel. Ensure both maintenance bars are properly positioned with respect to the roller channel.
3. Lower the HH by pressing the "DOWN" button until the scissor legs stop against the maintenance bars and the lift ceases to come down any further. Ensure that BOTH maintenance bars are fully and correctly engaged against the scissor leg structure. The maintenance bars MUST NOT be angled inwards towards the center of the lift.

To Disengage the Maintenance Bars

1. Raise the HH by pressing the 'UP" button until the rollers are well clear of the maintenance bars.
2. Rotate each maintenance bar back to its original position.

WARNING

MAINTENANCE BARS ARE TO BE USED ONLY WHEN THE LIFT IS UNLOADED. USE OF THE MAINTENANCE BARS TO SUPPORT A FULLY LOADED LIFT COULD RESULT IN SEVERE PERSONAL INJURY OR DEATH.

FIGURE 2: Safe Servicing of the Lifts

Your lift will be equipped with one of these maintenance devices

Note: In some cases the upper travel limit switch may need to be overridden to utilize the maintenance devices

Maintenance Bar

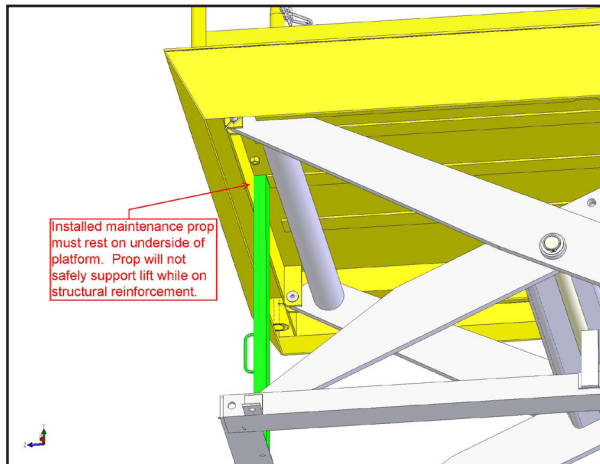
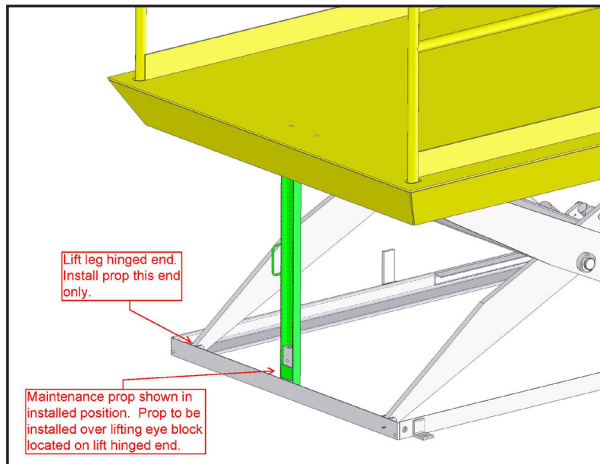
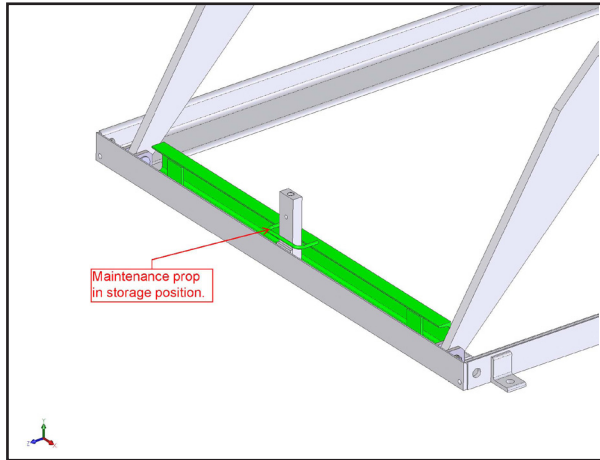

Flip in Style

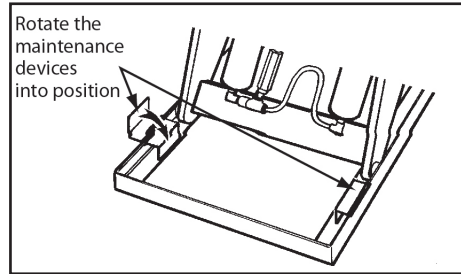

Block Style

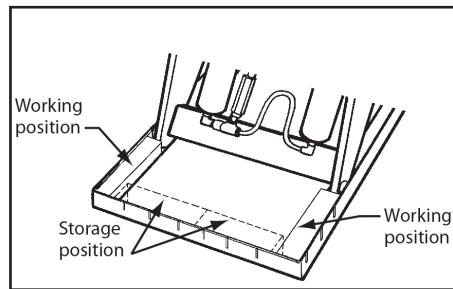

Block Style

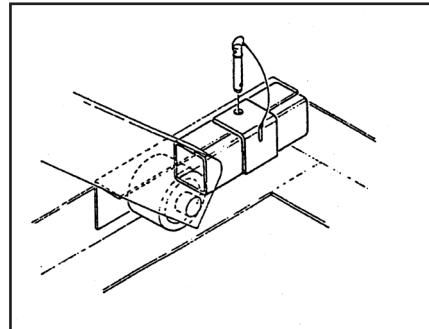

Maintenance Chock

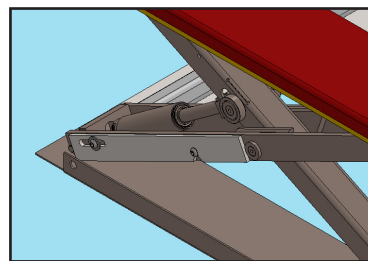

Maintenance Chock Disengaged (stored position)

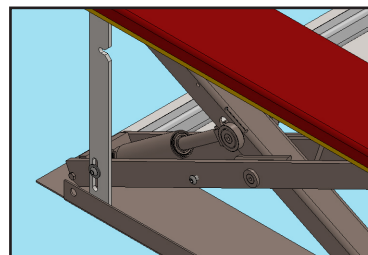

Maintenance Chock Engaged

INSTALLATION

The HH lift table is shipped on a skid covered with cardboard and wrapped with clear plastic, and requires minor assembly before it is ready to use. Suggested tools required are:

1. Banding or strap cutter
2. Drill motor with 1/2" concrete drill bit
3. 3/4" box or open end wrench, or 3/4" deep socket wrench
4. Hammer

1. Using a fork lift or similar equipment, move the palletized lift to the installation location. The installation area should be clean and have good general lighting.

2. Remove packaging material and any debris from the area. Using a strap cutter, remove the bands securing the lift to the skid. Remove all packing material from area. Ensure that any critical documentation shipped with the lift is saved.

3. Locate the 10' long power cord attached to the lift's base frame. A power plug is not supplied with the lift due to the many different types of electrical receptacles and installation options. Have a QUALIFIED ELECTRICIAN install a plug of the proper style and rating, on the power cord, or hard wire the cord directly into the electrical supply panel.

Ensure that both the power source and receptacle have the proper voltage, current and phase ratings for the lift's electric motor.

4. Insert the power plug into the receptacle and/or turn on the supply power to the unit.

5. Locate the lift's control station (hand or foot control), and depress the 'UP' button (or 'UP' pedal on foot control), and raise the lift to its maximum raised height. Following the Maintenance Bar Operating Instructions on page 8, engage the maintenance bars on each side of the lift. DO NOT lower the lift at this time.

6. Using a forklift, position the forks under the lift platform, along the platform length, so that the forks completely engage and support the sub-platform on each side of the lift. Exercise proper care so as not to damage the lift structure, control and power cords. Lift the HH off the pallet, and remove pallet from area. Position the lift in the desired location and orientation.

NOTE: The HH series lift base frame MUST be securely attached to the floor for maximum stability. Contact your Dealer, or Presto-ECO, if you have any questions regarding the proper installation of the lift

7. The lift table's base frame has four (4) 9/16" holes for lagging the unit securely to the floor. Two are located at the power unit end, near the scissor leg pivot blocks. The other two are located at the roller end of the lift, on the maintenance bar hinge plates. See Figure 3 for location. Using the four (4) holes as a template, drill a 1/2" diameter hole, 3 1/4" minimum depth at each location. The floor surface should be level, and the holes drilled perpendicular to the floor. If required, move the position of the lift with a forklift, exercising proper care, to allow room for drilling of the holes. Drill the holes, and when complete, reposition the lift.

8. Prepare the 1/2" diameter x 4" long anchor bolts. USE type SUP-R-STUD #26-12400 or equivalent. Assemble the washer and nut on the anchor bolt. The nut should be screwed onto the anchor bolt by approximately 1/2 the nut height. Drive the assembled anchor through the lift base lagging holes into the concrete until the washer is flush with the lift base structure. Expand the anchor shield by tightening the nut as required for a tight fit, approximately three (3) to five (5) turns. Repeat for the other anchors.

NOTE: Ensure that expanded bolt extends through the lift base by no more than 3/4". Interference with the scissor leg mechanism will result from bolts that extend through the base by more than 3/4".

NOTE: Correct installation and functionality of the anchor bolts is the responsibility of the lift owner, and/or installation contractor.

FIGURE 3: General Layout of the HH Series Lift

FIGURE 4 - GENERAL LAYOUT OF HLT SERIES LIFT:
PIT MOUNTED, WITH REMOTE POWER UNIT

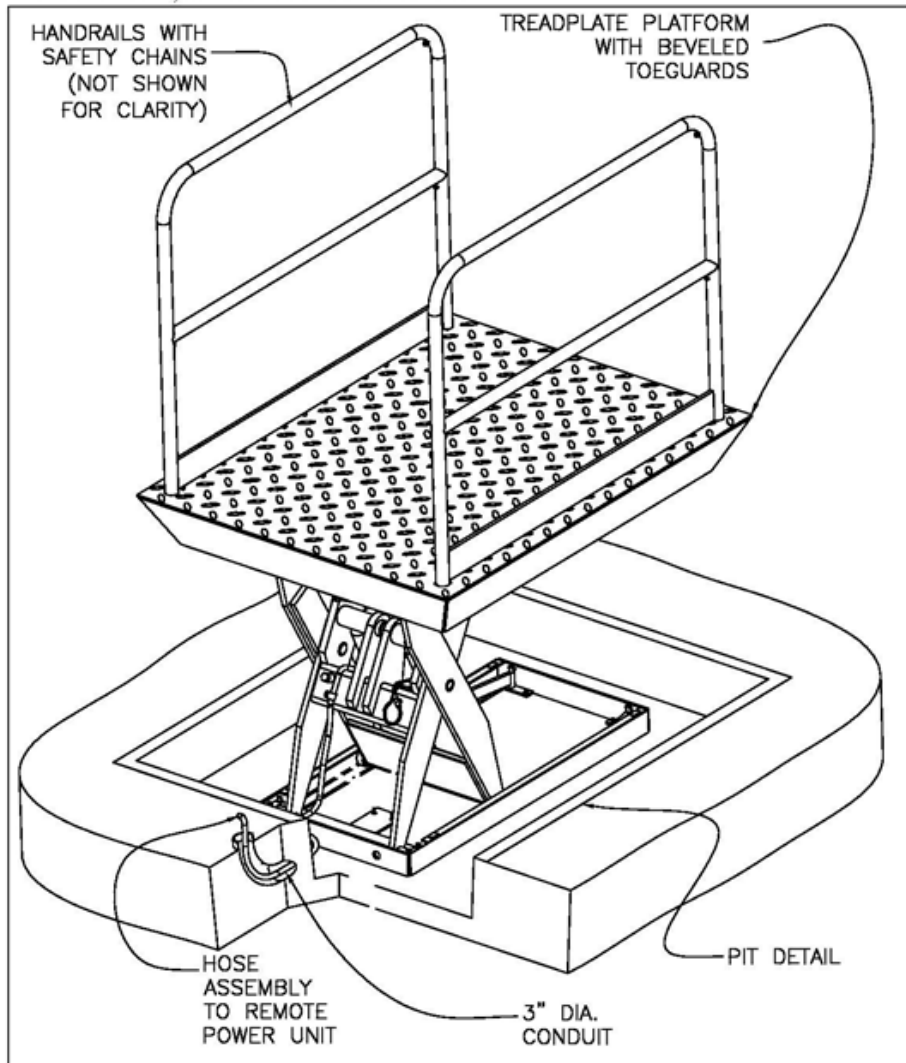

WARNING: The lift base frame **MUST** be fully supported. USE shims or concrete grout, if necessary, to ensure that the underside surface of the base frame is completely supported. Failure to completely support the base frame may cause structural damage to the lift, which may result in severe personal injury or property damage.

9. Disengage the maintenance safety bars as explained in “Scissor Blocking Instructions” section. Insert the power plug into the receptacle and/or turn on the lift power supply. Completely lower the platform by pressing the “DOWN” button until the unit is in the fully lowered position. (Note: Motor runs only when the Lift is raising. Only the Solenoid operates when the Lift is lowering.)

10. Run the lift up and down a few times, maintaining pressure on the ‘DN’ button, after the lift is in the fully lowered position, for approximately 10 seconds. This will remove any air trapped in the hydraulic system due to shipping.

11. The HLT Heavy Duty Industrial Lift is now ready for operation. Refer to “Operating Instructions” section for further information.

A general layout for a typical pit mounted HH Series Industrial Lift is shown in Figure 4.

Specific pit details and recommended dimensions are available from Presto-ECO upon the purchase of a pit mounted lift.

Presto-ECO A supplied pit details and dimensions are for recommendation and reference only. Actual pit design, details and dimensions, are the responsibility of the owner, and/or pit contractor.

General Notes Supplied by Owner or Contractor

1. Provide 3" dia. conduit with 12" minimum radius bends from Power Unit location to lift pit. As shown in Figure 4, the conduit entry should be to the power unit end of the lift installation.
2. Provide hydraulic hose or ASA steel tubing and fittings (minimum bursting pressure 12000 PSI) from the power unit location into the hinge end of the lift pit. For proper connection to the power unit and lift, the hose must have a # 6 (9/16-18) 37° flare (SAE J514) female swivel fitting on each end. Size and construction of the hose should be as follows:
 - (a) For hose lengths up to 50 feet, use 3/8" ID hydraulic hose
 - (b) For hose lengths greater than 50 feet, use 1/2" ID hydraulic hose
3. If the optional limit switch is purchased, provide a #16 AWG 2-wire conductor (type SO) from the control box to the limit switch located within the lift base frame.
4. Ensure the concrete is reinforced to suit local soil conditions. All pit construction including the bumper posts, curb angles, conduit, hydraulic oil, hydraulic connections and electrical hook-up are the responsibility of the owner and/ or the pit contractor.
5. Pit drains are to be installed to suit local code and weather conditions.
6. Service wiring and/or relocation of the power unit controls are the responsibility of the contractor and/or the owner.

It must be clearly noted that the sole purpose of the pit details and dimensions supplied with the purchase of a pit mounted lift, is to document the configuration of the equipment built by Presto-ECO A and any specific installation data pertinent to the satisfactory operation thereof. It is not the Intent of Presto-ECO A to provide installation details such as concrete thickness and reinforcing, routing of electrical and hydraulic lines, component location and orientation, position of adjacent structures, etc., but rather, to make recommended construction drawings for the specific job requirement.

OPERATING INSTRUCTIONS

The load capacity rating as stamped on the nameplate of your HH designates the maximum lifting capacity with a uniformly distributed load. This capacity must never be exceeded, as permanent damage may result. The maximum rollover capacity in the fully lowered position is 10000 lbs. capacity; lowering loads that exceed the rated capacity will result in excessive wear or damage to the lift.

The maximum static edge and axle load capacities over the sides and ends are stamped on the nameplate. The static edge and axle load capacities must be de-rated for cases where the lift platform is modified in the field. Consult the factory before any modification is performed in the field.

NOTE: ANY modification of the lift in the field, without the express written consent of Presto-ECO A, will void any and all warranties.

The HH is furnished with constant pressure ("dead-man" type) push button controls. Pressing the "UP" button, starts the motor (see wiring diagram), this in turn runs the hydraulic pump. The cylinders begin to extend and the platform starts to rise. The platform will rise as long as the "UP" button is pressed. On releasing the button, the platform ceases to rise and will remain at that particular elevation.

When pressing the "DN" button, the Down Solenoid Valve is energized. The cylinders start retracting as the oil returns to the reservoir and, upon releasing the button the platform ceases to lower, remaining at that particular elevation.

When the lift reaches its full vertical travel, the cylinders have extended to their maximum limit. The plat-

form will no longer travel up due to the internal stops in the cylinders. At this point the relief valve will open because of pressure build up and oil will bypass into the reservoir. Do not continue to operate the lift as it will create excessive wear on the pump.

In the event that the lift is overloaded, the relief valve will open because of excessive pressure build up, and oil will bypass into the reservoir. When the lift reaches a preset vertical travel the "up limit switch" (if purchased) will be actuated. This shuts off the power to the motor. At this point, pressing the "UP" button will have no effect. The platform will remain stationary at the desired elevation.

Always remember that the motor runs only when the "UP" button is pressed and the Down Solenoid Valve is energized only when the "DOWN" button is pressed.

1. Always load the lift properly by centering the load on the platform as much as possible.
2. Never use the lift if it is in need of repairs, or in the case of a malfunction.
3. Notify your maintenance personnel if you notice anything out of the ordinary, such as binding, odd pump noises, etc.
4. Do not continue to press the "UP" button if the lift is not rising. You can permanently damage the motor or pump by doing so.
5. Ensure that handrails and chains (where applicable) are in place before operating the lift.

ROUTINE MAINTENANCE

Raise the lift and engage the maintenance safety bars before beginning any inspection or work on the unit.

(A) Monthly Inspections

1. Check oil level. It should be about 1" below top of the tank with the lift in fully lowered position. Add oil as required. (See oil specifications.)
2. Check for oil leaks. See Trouble Shooting Section and correct as necessary.
3. Check roller bushings, axle pin, clevis and pivot points for wear.
4. Check for worn or damaged hydraulic hoses or electrical cords. Repair as necessary.
5. Check rollers for looseness and wear, See Trouble Shooting.
6. Check retaining rings at all axles, pivot points and clevis.
7. Never grease rollers or axles.
8. Check for unusual noise. See Trouble Shooting.

(B) Yearly Inspection

Oil in reservoir should be changed at least once a year, or sooner if the oil darkens or becomes gritty. Presence of water is indicated if the oil turns milky.

(C) Winter/Summer Maintenance

Change the oil as per 'Oil Viscosity Recommendations' depending on the ambient temperatures prevailing in your area.

Optional Limit Switch Adjustments

At times it is necessary to change the vertical travel so that the platform top is level with a surrounding structure. Adjusting the Limit Switch arm position will vary the vertical travel, from the maximum raised height to approximately 6-8" below the maximum raised height.

The Optional Limit Switch Assembly is shown in Figure 4.

OPERATION

When the operator wants to raise the platform, he or she presses the “UP” button. This starts the electric motor, which runs the hydraulic pump. Oil from the reservoir is sucked in through the suction filter and into the pump. The pump delivers the pressurized oil through the internal check valve before entering the cylinders. The function of the check valve is to allow the oil to flow in one direction i.e. towards the cylinders. It also prevents the flow of oil back into the pump circuit when the pump stops running. This holds the oil in the cylinders and maintains the desired elevation.

If the load is excessive, and the “UP” button is still pressed, pressure will build up in the circuit between the pump and the cylinders. This forces the “ball” or “poppet” in the relief valve to unseat and the pump output returns into the reservoir through the return pipe.

When the operator desires to lower the lift, he or she presses the “DN” button. This energizes the down solenoid valve. The poppet in the solenoid valve is unseated and oil now returns from the cylinders through the flow control valve, the solenoid valve, and into the reservoir.

The flow control valve controls the down speed of the lift.

Releasing the “DN” button will de-energize the solenoid, closing the valve poppet. This prevents the oil from returning to the reservoir and the cylinders will stop retracting. The lift is now maintained at that particular elevation.

An optional flow limiter may be installed at the base of each cylinder. In the event of a hydraulic hose failure, the platform lowers at a fast rate. As soon as the descent speed exceeds the preset speed, the flow limiter will shut off the oil flow and the platform will come down at a very slow speed until pressure is reapplied. This safety feature reduces the possibility of accidental personal injury or damage to the lift.

Table 1 – Hydraulic Oil Specifications

If the lift will be used at normal ambient temperatures, Presto-ECO A supplies the unit with Conoco Super Hydraulic 32 oil. This may be replaced by any other good quality oil with 150 SSU at 100° F and rust and oxidation inhibitors and anti-wear properties. If the lift will be used at ambient temperatures below 0°F, use aircraft hydraulic oil. Use Type 15 aircraft hydraulic oil.

The following are equivalent to Conoco Super Hydraulic 32:

TYPE	MANUFACTURER
AW32	CITGO
DTE 24	EXXON/MOBIL
NUTO H32	EXXON/MOBIL
AMOCO AW32	CHEVRON (AMOCO CO.)

CAUTION

It is very important to keep the hydraulic oil free of dirt, dust, metal chips, water, and other contamination. Most of the problems with hydraulic systems are caused by contamination in the oil.

FIGURE 4: Optional Limit Switch Assembly

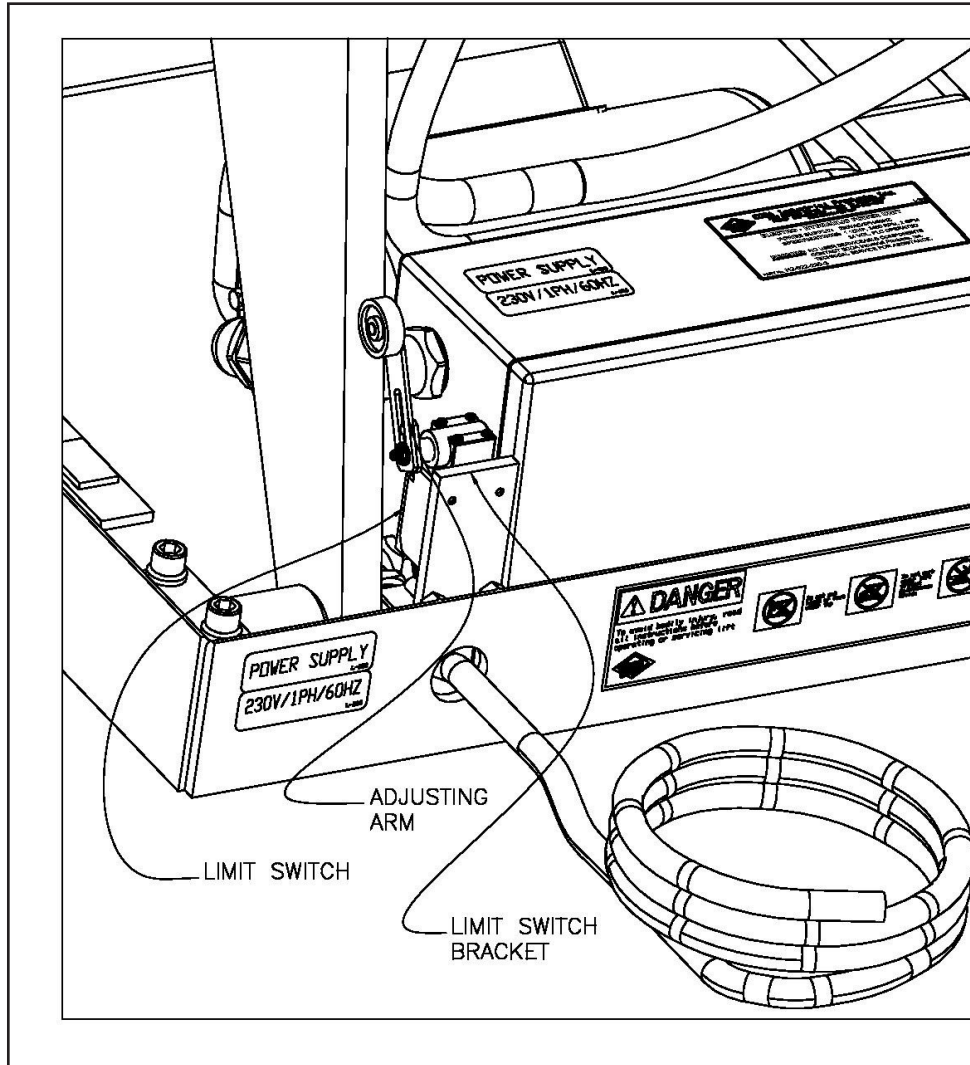
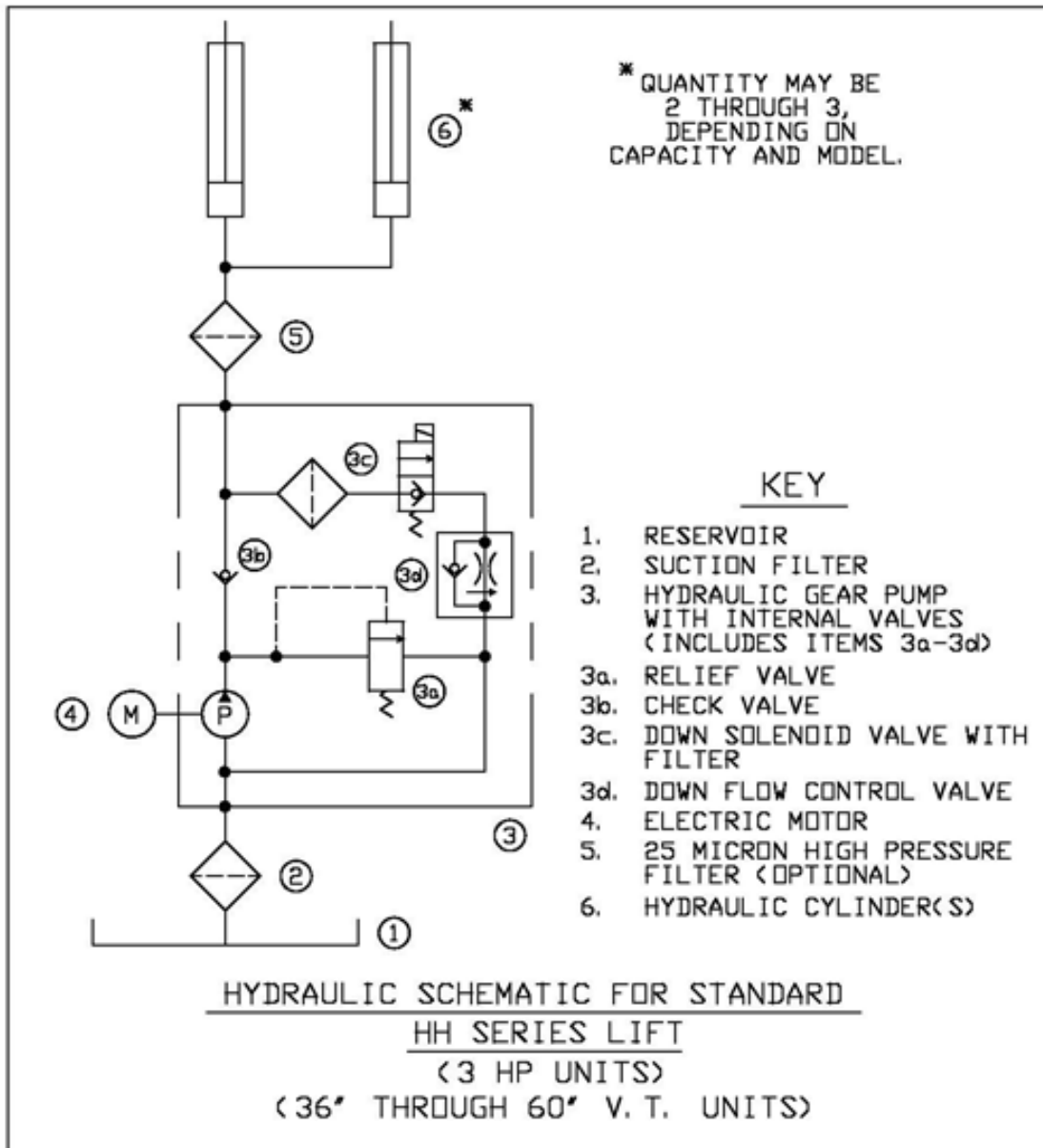

FIGURE 5: Hydraulic Schematic for Standard HH Lift



ELECTRICAL SECTION

The standard power unit is pre-wired according to customer request. For supplied power other than the original configuration, the power unit **MUST** be re-wired according to the Manufacturer's instruction sheet (see Figure 9). Service and Field wiring is the sole responsibility of the end user. Presto-ECOAs assumes no responsibility for incorrect installation or service wiring.

Install the power lines to conform to National Electrical Code (NEC) 480-22 and the local codes.

Given below are the various electrical components used on the Lift. A brief description of each is also given.

FIGURE 9: Electrical Schematic for 230V/1ph/60Hz Supply

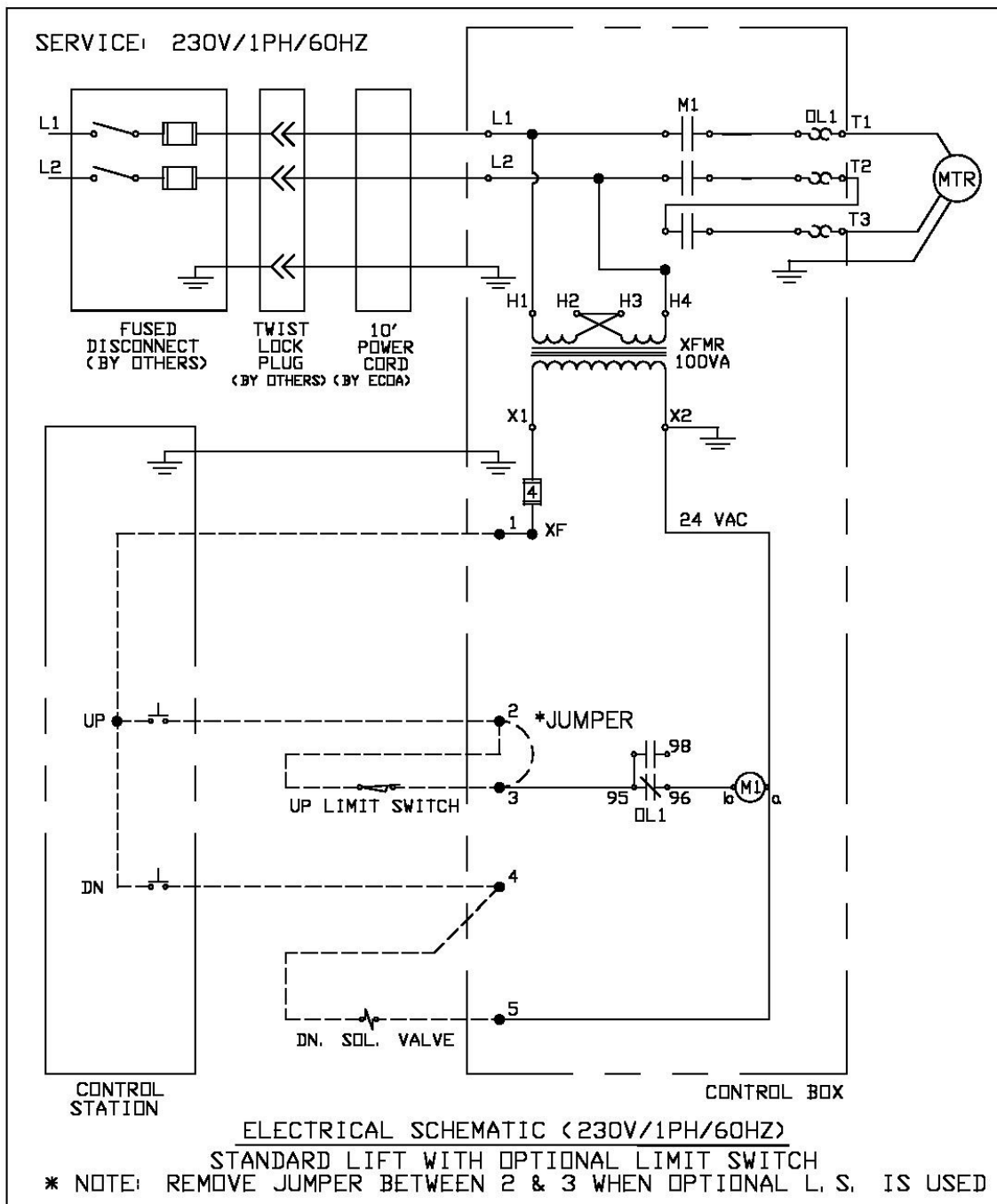

FIGURE 10: Electrical Schematic for 208-230V/460V/3PH/60Hz

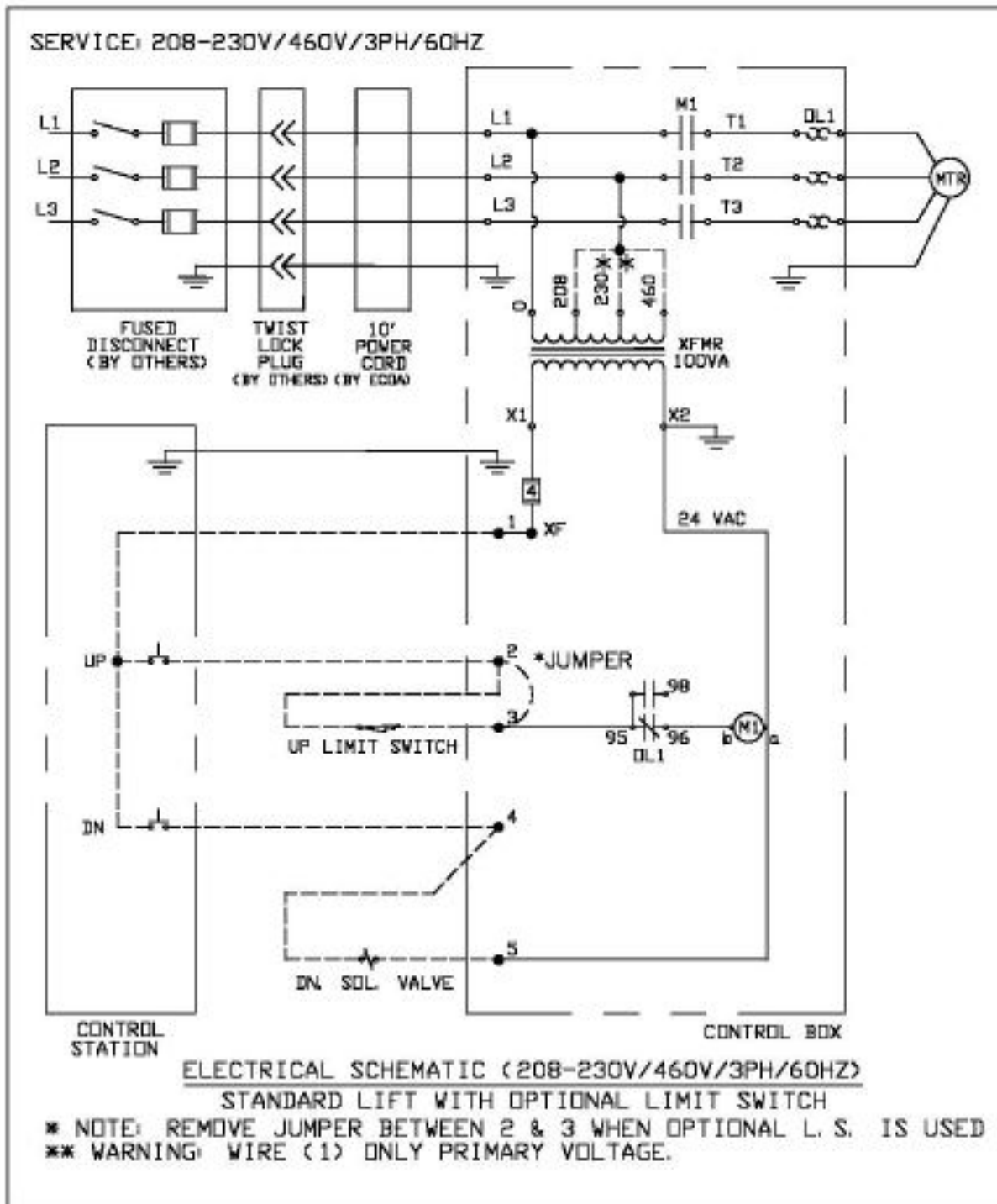

FIGURE 13: Exploded front view of HLT/HH Series

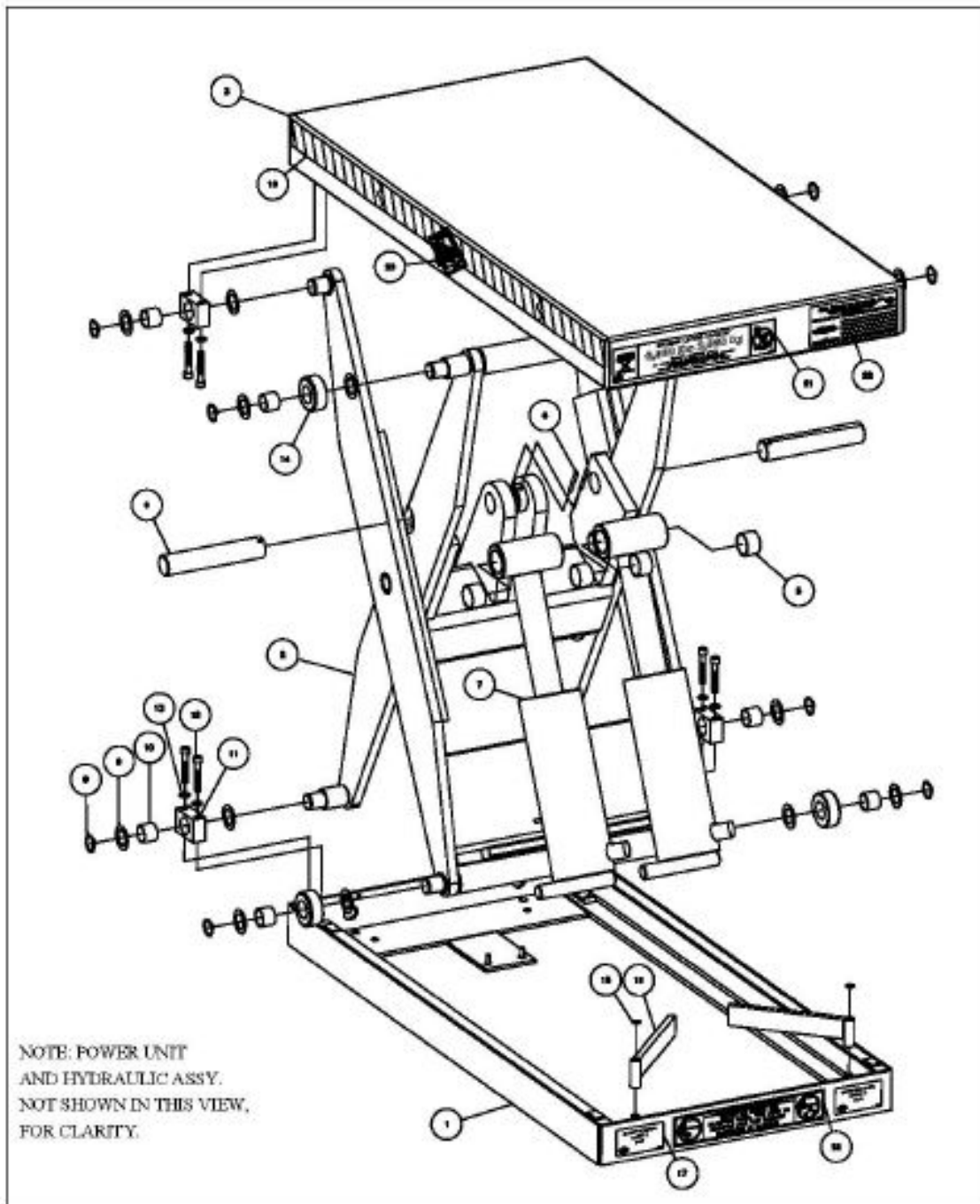
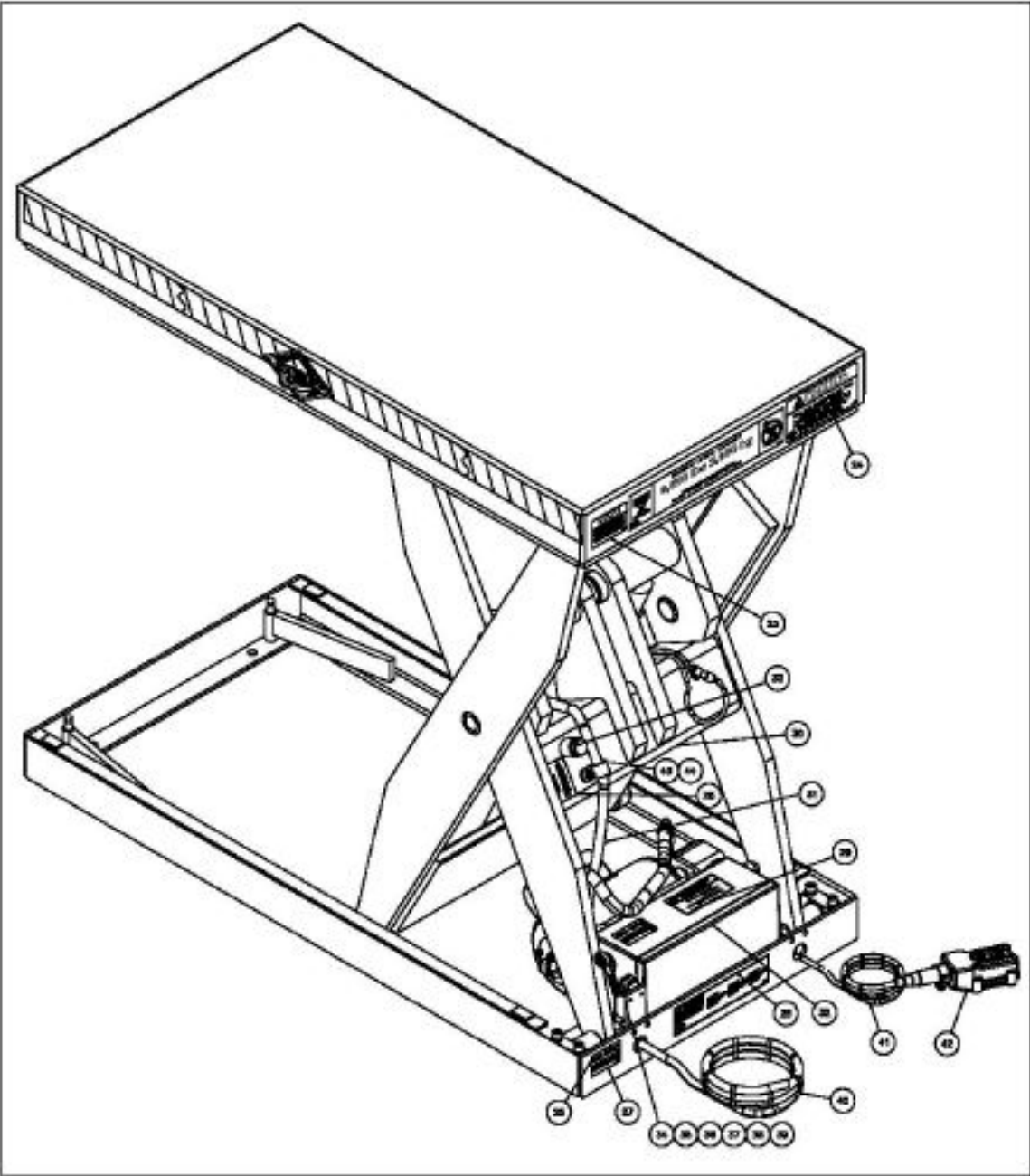

FIGURE 14: Exploded back view of HLT/HH Series



TROUBLESHOOTING

Observation	Possible Cause	Remedy	
1. Lift does not raise but pump is running	a. Motor rotation maybe reversed. or humming	a. Change motor rotation per notes in Electrical Section. If Lift has been running properly for some time, then it is possible that plant wiring has been changed and the motor is now running reversed.	
	b. Motor may be single phasing, (humming).	b. Check wiring and overloads, fuses, etc., to ascertain that all 3 phase lines are present at the motor.	
	c. Voltage at motor terminals may be too low to run pump at existing load.	c. Measure voltage at motor terminals, or as near as possible. while pumps running under load. If voltage is sufficient, check for inadequate or incorrect wiring as this can starve the motor. Correct as necessary.	
	d. Hose or hydraulic line is leaking.	d. Correct as necessary.	
	e. Oil level in reservoir is low.	e. Add oil.	
	f. Load exceeds capacity requirements. Relief Valve is bypassing the oil back into tank.	f. Do not change Relief Valve setting. Instead, reduce the load to rated capacity.	
	g. Suction filter is clogged, starving pump.	g. Remove and clean.	
	h. Suction line may be leaking air, due to loose fittings.	h. Check fittings.	
	i. Filler/Breather capon tank may be clogged.	i. Remove and clean.	
	j. Down Valve may be energized by faulty wiring, or stuck open.	j. Remove Solenoid Valve, check and clean. (See Hydraulic Section.)	
	k. Hydraulic pump may be inoperative.	k. Disconnect hydraulic line at power unit. Put hose end in a large container and run pump again. If no output, check motor rotation as per 1(a) above. If pump is worn, replace with a new pump.	
	2. Lift raises too slowly.	a. Foreign material stuck in Down Solenoid, causing some oil to bypass back into tank.	a. Lower the Lift. Remove the Solenoid Valve and clean it. (See Hydraulic Section)
		b. Foreign material clogging suction filter, breather cap, pressure line filter, or a pinched hose.	b. Correct as necessary. (See also 1(g), (i).)
c. Low Motor voltage.		c. See 1(c).	
d. Lift overloaded.		d. See 1(f).	
e. Oil is too thick for proper operation.		e. Refer to "Oil Viscosity Recommendations"	
f. Lift operates with a shuddering vibration.		f. Cylinder may be binding. Check with factory.	
g. Pump is inoperative		g. See 1(k).	
3. Motor labors or heats excessively.	a. Voltage may be low.	a. See 1(c).	
	b. Incorrect wiring	b. Check that one leg of the motor lines is not connected to ground.	
	c. Oil starvation causes pump to bind. High internal heat is developed if this occurs, pump may be permanently damaged.	c. See 1(e). (g). (h). (i). (k).	
	d. Binding cylinders.	d. See 2(f).	
	e. Oil may be too thick.	e. See "Oil Viscosity Recommendations"	

Observation	Possible Cause	Remedy
4. "Spongy" or "Jerky" Lift operation. Do not confuse spongy operation with small surges caused by foreign material on Lift wheel roller plate.	a. Air trapped in cylinders.	a. Bleed cylinders by lowering Lift fully and hold "DOWN" button for 20-30 seconds more. Raise Lift and repeat procedure several times. Bleed cylinders also, by loosening bleeder screws (item 145) until a steady stream of oil comes out.
	b. Oil starvation.	b. See 1(e). (g). (h). (i).
5. Lift lowers too slowly when loaded.	a. Down Valve filter clogged.	a. Remove Solenoid Valve and clean it.
	b. Pinched tube or hose.	b. Correct as necessary. (In case of pipe, check for obstruction inline.)
	c. Oil too thick.	c. See "Oil Viscosity Recommendations"
	d. Foreign material in Flow Limiter.	d. Remove and clean.
	e. Binding cylinders.	e. See 2(f).
6. Lift lowers too quickly.	a. Leaking hoses. Cracked fittings	a. Correct as necessary. Check underground conduit for evidence of fluid.
	b. Check valve stuck open. (The combination of a stuck Check Valve and open Solenoid Valve will cause excessive speeds.	b. Remove Check Valve and clean it. (See Hydraulic Section)
7. Lift raises then lowers slowly.	a. Down Solenoid Valve may be incorrectly wired or is stuck open due to dirt.	a. See 2(a).
	b. Check Valve may be stuck open.	b. Remove and clean. (See Hydraulic Section.)
	c. Check for leaking hoses, fittings, pipes.	c. Correct as necessary.
	d. Cylinder seals may be worn or damaged.	d. Replace seals. (See Cylinder Repair procedure.)
	e. Faulty Down Solenoid Coil.	e. Remove and replace.
8. Lift has raised, but does not lower.	a. Blown electrical fuse.	a. Check and replace.
	b. Incorrect Down Solenoid Valve wiring.	b. Correct as necessary. (See Wiring Diagram.)
	c. Down Solenoid Valve is stuck.	c. Lightly tap down the Solenoid Coil body to seat it properly. Do not hit hard as it will permanently damage the internal stem. Do not remove the Solenoid Valve from the Block as the unit will come down at a dangerous speed.
	d. Faulty Down Solenoid Coil.	d. Remove and replace.
	e. Maintenance safety bar, or some other object blocking down travel.	e. Raise Lift and remove the safety bar, or whatever object is blocking the down travel, then press the down button.
	f. Binding cylinders.	f. See 2(f).

Presto-ECO Lifts Limited Warranty Policy

Presto-ECO Lifts warrants all of its products against defects in the welded structural frame and, if applicable, scissor legs from faulty material and workmanship for a period of five years from the date of invoice.

All other components have a limited warranty against defects in faulty material and workmanship for a two year period from the date of invoice date of invoice and 30 day limited warranty on labor. Please note that prior authorization from Presto-ECO Lifts is required on all warranty work.

There are no implied warranties of any kind, more specifically, there are no warranties of merchantability or fitness for any particular purpose. Presto-ECO Lifts' sole warranty shall be as set forth in this limited warranty.

Presto-ECO Lifts will elect to repair or replace a defective component without charge, if any components should become defective within the limited warranty period. Proof of purchase is required for warranty. The charge for shipping the defective component is the responsibility of the buyer and must be accompanied with an RMA number. The shipping charge to return the component to the buyer is the responsibility of Presto-ECO Lifts.

This limited warranty does not cover labor expense for removal or reinstallation of components after thirty days. This limited warranty shall not cover, among other things: damages resulting from foreign matter or water, failure to provide reasonable and necessary maintenance, and if applicable, use of product while charger is plugged into an AC outlet, or failure to follow operating instructions. The limited warranty is not valid for damage resulting from negligence, accident, unreasonable use, abuse or misuse, exceeding data plate capacities or altering the product without Presto-ECO Lifts authorization.

Presto-ECO Lifts expressly disclaims and excludes any liability for consequential, incidental, indirect or punitive damages or financial loss to people or property resulting from any breach of warranty or the operation or failure of this product.

Presto-ECO Lifts makes no representation that this product complies with local, state, or federal safety/product standards codes. Should this product fail to comply in any way with those codes, it shall not be considered a defect of materials or workmanship. Presto-ECO Lifts shall not be held liable for any damages resulting from noncompliance. It is the dealer's responsibility to exercise this limited warranty. This limited warranty is provided to the original purchaser (defined as the original end user) and is nontransferable. This constitutes the complete and final agreement involving Presto-ECO Lifts limited warranty obligations for products.