

DSL

for series
DSL, TSL, QSL

Installation, Operation and Service Manual

Model Number _____

Serial # _____

Date placed in service _____

**IMPORTANT: READ CAREFULLY
BEFORE INSTALLING OR OPERATING LIFT**

Part orders are subject to a \$50 minimum charge.



This manual was current at the time of printing. To obtain the latest, most updated version, please contact Presto-ECO Lifts Customer Service Department or go to our website: www.PrestoLifts.com where you will find a complete list of current owner's manuals to print.

CONTENTS

INTRODUCTION	4
RESPONSIBILITY OF OWNERS AND USERS	5
SAFETY ALERT SYMBOLS AND SIGNAL WORDS.....	6
SAFE SERVICING	7
SAFETY PRECAUTIONS.....	8
INSTALLATION INSTRUCTIONS	9
Preparation	9
Positioning the Lift	10
Hydraulic Connections	10
Electrical Connections.....	11
Completing Installation	12
OPERATING INSTRUCTIONS	12
Operating Procedure	12
Labels and Precautionary Markings	13
MAINTENANCE	14
Hazards	14
Troubleshooting Check List & Warnings.....	16-17
ORDERING REPLACEMENT PARTS	18
2 YEAR WARRANTY	23

List of Figures

Figure 1	Safe Servicing of Lift	7
Figure 2	Mount the Lift Securely	9
Figure 3	Using Lifting Eyes	9
Figure 4	Center the Load	11
Figure 5	Secure the Load	11
Figure 6	Labels & Precautionary Markings	13
Figure 7	Pinch Points	14
Figure 11	Electrical Connections, Lifts Wired for Single-Phase AC	19
Figure 12	Wiring Diagram, Lifts Wired for Single-Phase AC with limitswitch	20
Figure 13	Electrical Connections, Lifts Wired for Three-Phase AC	20
Figure 14	Schematic, Lifts Wired for Three-Phase AC	21
Figure 15	Hydraulic Connections	21
Figure 16	Hydraulic Diagram	22

Tables

Table 1	Hydraulic Oil Specifications	10
Table 2	Electrical Interface, Supplied by Customer	22

SECTION 1

INTRODUCTION

This manual attempts to provide all of the information necessary for the safe and proper installation, operation and maintenance of scissor Lifts. It is important that all personnel involved with the installation, maintenance or operation of the scissor lift read this manual.

Where unique situations arise, that are not covered in this manual, call Presto-ECO Lifts for further instructions. Additional manuals are available upon request or on our web site at www.prestolifts.com.

The scissor lift has a nameplate that provides the load capacity ratings, serial number and model identifications. Please refer to these numbers when ordering parts or requesting further information.

The scissor lifts are designed for lifting, lowering and positioning a variety of loads. WHERE UNIQUE SITUATIONS ARISE, THAT ARE NOT COVERED IN THIS MANUAL, CALL PRESTO-ECO LIFTS FOR FURTHER INSTRUCTIONS.

The scissor lifts are designed for inplant/nonhazardous location use only. These units are not for personnel lifting.

Responsibility of Owners and Users

Inspection and Maintenance

The device shall be inspected and maintained in proper working order in accordance with Presto-ECO's owner's manual.

Removal from Service

Any device not in safe operating condition such as, but not limited to, excessive leakage, missing rollers, pins, or fasteners, any bent or cracked structural members, cut or frayed electric, hydraulic, or pneumatic lines, damaged or malfunctioning controls or safety devices, etc. shall be removed from service until it is repaired to the original manufacturer's standards.

Repairs

All repairs shall be made by qualified personnel in conformance with Presto's instructions.

Operators

Only trained personnel and authorized personnel shall be permitted to operate these lifts.

Before Operation

Before using the device, the operator shall have:

- Read and/or had explained, and understood, the manufacturer's operating instructions and safety rules.
- Inspected the device for proper operation and condition. Any suspect item shall be carefully examined and a determination made by a qualified person as to whether it constitutes a hazard. All items not in conformance with Presto's specification shall be corrected before further use of these lifts.

During Operation

The device shall only be used in accordance with this owner's manual.

- Do not overload.
- Ensure that all safety devices are operational and in place.

Modifications or Alterations

Modifications or alterations to any Presto-ECO industrial positioning equipment shall be made only with written permission from Presto.

SAFETY ALERT SYMBOLS AND SIGNAL WORDS

The safety of all persons operating, maintaining, repairing, or in the vicinity of this equipment is of paramount concern. This is a powerful machine with moving parts, and is capable of causing personal injury if proper precautions are not taken. Therefore, throughout this manual, certain hazards have been identified which may occur in the use of the machine, and there are appropriate instructions or precautions which should be taken to avoid these hazards. In some cases, there are consequences which may occur if instructions or precautions are not followed. Below are the symbols and signal words along with their definitions referenced from ANSI Z535.4 - Product Safety Signs and Labels.

4.11 Safety Alert Symbols: A symbol that indicates a hazard. It is composed of an equilateral triangle surrounding an exclamation mark. The safety alert symbol is only used on hazard alerting signs. It is not used on safety notice and safety instructions signs.



A): for use with DANGER signal word; (safety white triangle, safety red exclamation mark, safety red background)

B): for use with WARNING signal word; (safety black triangle, safety orange exclamation mark)

C): for use with CAUTION signal word; (safety black triangle, safety yellow exclamation mark)

D) and E): for use with DANGER, WARNING, or CAUTION signal word; (D: is a safety yellow triangle with a black border and safety black exclamation mark; E: is a safety yellow triangle with a safety black exclamation mark and a safety yellow border around a safety black band)

NOTE: D and E are provided to allow for consistency with certain ISO standards such as ISO 3864-1 and ISO 3864-2.

4.14 Signal Words: The words used in the signal word panel. The signal words for hazard alerting signs are “DANGER,” “WARNING,” and “CAUTION.” Safety notice signs use the signal word “NOTICE.” Safety instruction signs use signal words that are specific to the situation.



DANGER indicates a hazardous situation which, if not avoided, will result in death or serious injury.



WARNING indicates a hazardous situation which, if not avoided, could result in death or serious injury.



CAUTION indicates a hazardous situation which, if not avoided, could result in minor or moderate injury.



NOTICE is used to address practices not related to physical injury.



SAFETY INSTRUCTIONS (or equivalent) signs indicate specific safety-related instructions or procedures.

NOTE: DANGER, WARNING or CAUTION should not be considered for property damage accidents unless personal injury risk appropriate to these levels is involved.

SAFE SERVICING OF THE LIFT

⚠️ WARNING

Only authorized personnel should perform inspection or maintenance and service procedures. Unauthorized personnel attempting these procedures do so at the risk of severe injury or death.

⚠️ DANGER

Failure to properly adhere to lift blocking procedures is to risk the sudden and uncontrolled descent of the lift during maintenance or inspection. A falling lift can cause severe injury or death.

This procedure describes the only factory-approved method of working under a lift. Follow these instructions **EVERY** time you plan to reach or crawl beneath the lift to perform service or maintenance – no matter how momentary that might be.

If the factory-provided maintenance device is damaged or missing, stop immediately and consult the factory for assistance. The manufacturer is not liable for your failure to use the approved maintenance device(s) and procedures that have been provided.

1. Any load must be removed from the lift prior to engaging the maintenance device(s). These devices are designed to support an unloaded lift only. Failure to remove the load from the lift prior to blocking could cause the failure of the maintenance device(s) and allow the lift to fall unexpectedly. This can result in personal injury or death, or permanent damage to the maintenance device(s) and/or the lift.
2. Raise the lift to its fully raised position. If you do not, the maintenance device(s) may not be able to be placed properly in its/their designed blocking position.
3. Remove the maintenance device(s) from its/their storage location and place it/them into the engaged position as shown in Figure 1.
4. Lower the lift until it makes complete contact with the maintenance device(s). Re-check to ensure that all provided devices are fully and securely engaged. If the device(s) is/are not fully engaged the lift could fall unexpectedly, resulting in permanent damage to the device(s) or the lift.

⚠️ DANGER

If for any reason you are unable to lower the lift completely onto the maintenance device(s), stop immediately and consult the factory. Failure to properly use the

factory approved maintenance device(s) could result in severe injury or death.

5. (For single-acting hydraulic, and pneumatic lifts) Once the maintenance device(s) is/are properly and securely engaged, continue to press the down button, valve or switch for an additional 5-10 seconds to relieve all pressure in the operating system.

⚠️ WARNING

Failure to relieve operating system pressure could result in the sudden and unexpected release of high pressure fluids (or air) during maintenance and/or repair of the lift and result in severe injury or death.

6. Follow OSHA electrical lock-out/tag-out procedures. Disconnect and tag all electrical and/or other power sources to prevent an unplanned or unexpected actuation of the lift.
7. Once inspection or work is complete, reverse the performance of the steps above to raise the lift off the maintenance device(s) and place the device(s) back into its/their designated storage position(s).

⚠️ DANGER

HIGH VOLTAGE ! – Disconnect and/or lock out the electrical supply to the power unit prior to any installation or maintenance being performed.

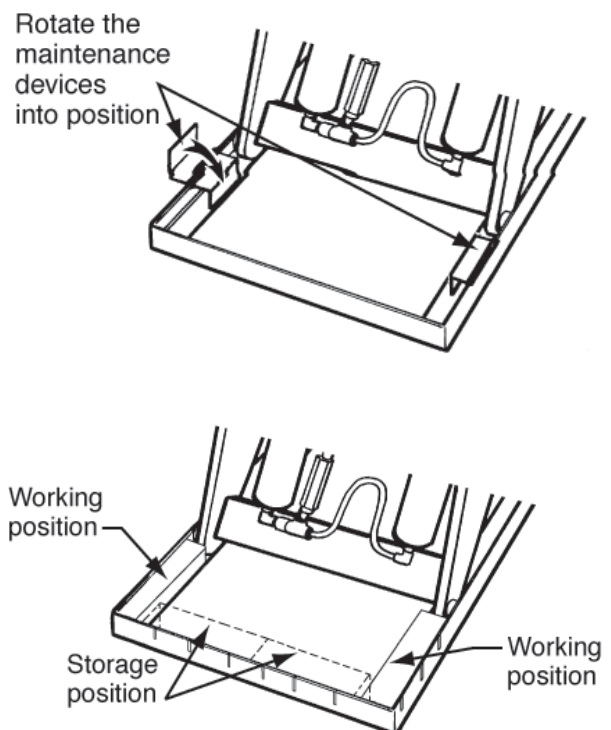

Fig. 1 – Safe Servicing of Lift

SECTION 2

SAFETY

The safety of all persons installing, using, servicing, or working near the unit is of paramount concern to Presto-ECOALifts. The lift is a powerful machine with moving parts, and is **capable of causing personal injury if proper precautions are not taken**. Therefore, throughout this manual, Presto-ECOALifts have identified certain hazards, which may occur in the use of the unit, and provided appropriate **instructions** or precautions that should be taken to avoid these hazards. In some cases, Presto-ECOALifts has also pointed out the **consequences** that may occur if Presto-ECOALifts instructions or precautions are not followed. Presto-ECOALifts use the following nationally recognized system for identifying the severity of the hazards associated with its products:

▲ DANGER Immediate hazard that will result in severe personal injury or death.

▲ WARNING Hazard or unsafe practice, that could result in severe personal injury or death.

▲ CAUTION Hazard or unsafe practice, that could result in minor personal injury or property damage.

In the interest of safety, please read the entire manual carefully. You must understand the material in this manual before you install, use, or service the unit. If you have any question about any of the instructions in this manual, please contact Presto-ECOALifts at 1-800-343-9322.

SAFETY INSTRUCTIONS

- Do not perform any repair work on a lift with a load on the platform or with the table in a raised position.
- All personnel must stand clear of the lift when the lift is in motion.
- Do not put hands or feet under lift table.
- Do not perform any repair or maintenance work with the lift in an open position without securing it first with proper maintenance devices.
- Do not stand, sit or climb on the lift at any time.
- Do not use the lift on soft, uneven or unstable surfaces.
- Do not exceed the load capacity rating on the data plate.
- Do not place a load on a moving lift.
- Do not exceed load capacity.
- Place a load in the center of the lift and be sure that the load is secured properly.

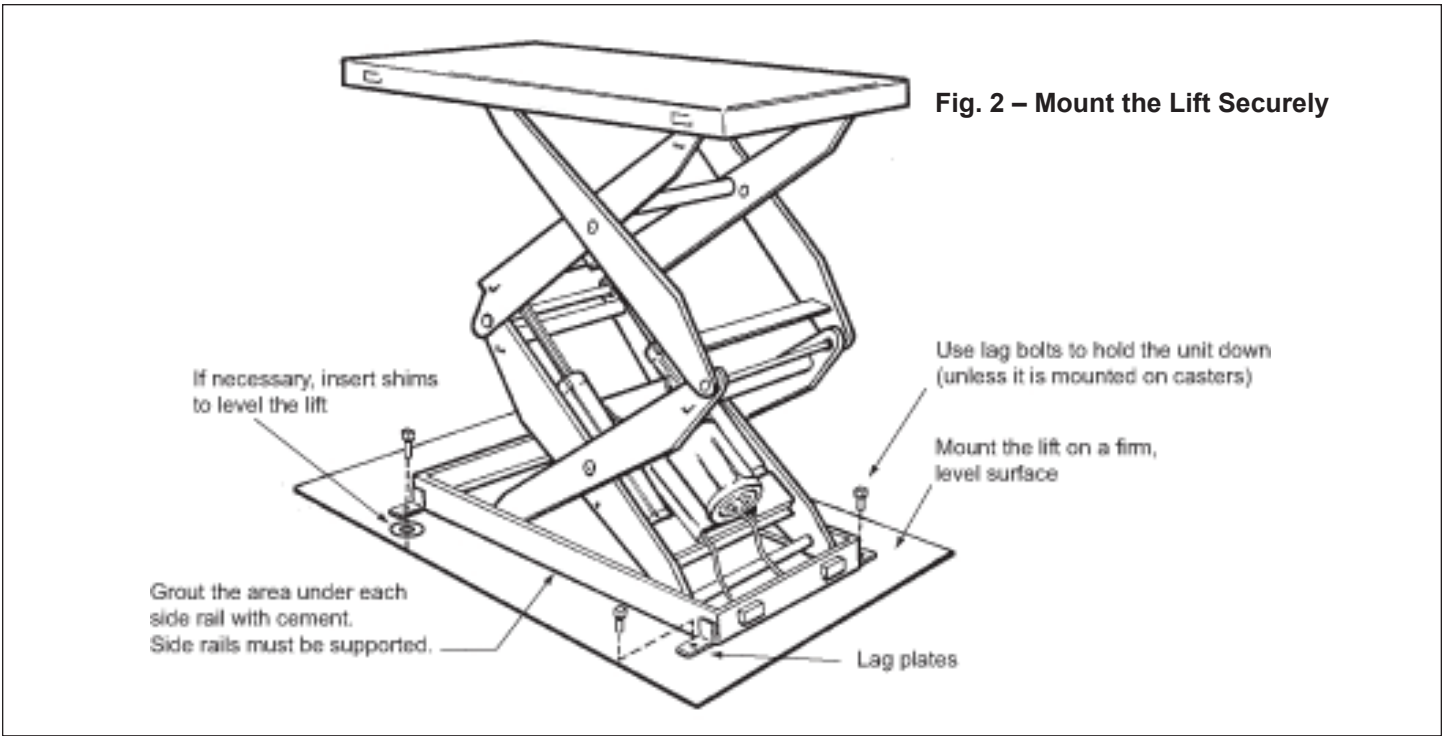

Fig. 2 – Mount the Lift Securely

INSTALLATION INSTRUCTIONS

Preparation

1. Before you start to install the lift, check for local codes and ordinances which may apply. It is your responsibility to obtain any necessary permits.
2. **Read all of these installation instructions carefully. Be sure to read and understand all of the warnings!**
3. If your unit is designed to be installed in a pit, check the pit before you start to install the lift. Measure the length and width of the lift table, then measure the pit, and be sure the pit allows adequate clearance. Does the pit have 90° angles at each corner? To check, measure across the opposite corners of the pit. The measurement on each diagonal should be the same, within 1/2 inch. The walls of the pit should be vertical. Check with a carpenter's square.

4. If the power unit will be mounted away from the lift ("external power unit"), check the mounting arrangement for the power unit. The power unit should be sheltered from the weather. It should be mounted within 30 feet of the lift to minimize the pressure drop in the hydraulic system. Be sure the hydraulic lines have been installed properly.

⚠ WARNING

Protect the power unit from rain or moisture. If the electrical parts in the power unit get wet, workers may be hurt by electrical shock. The electrical parts may fail if they are wet.

⚠ WARNING

The electric motor in the lift can create sparks. Don't install the power unit in an area where flammable gases may be present.

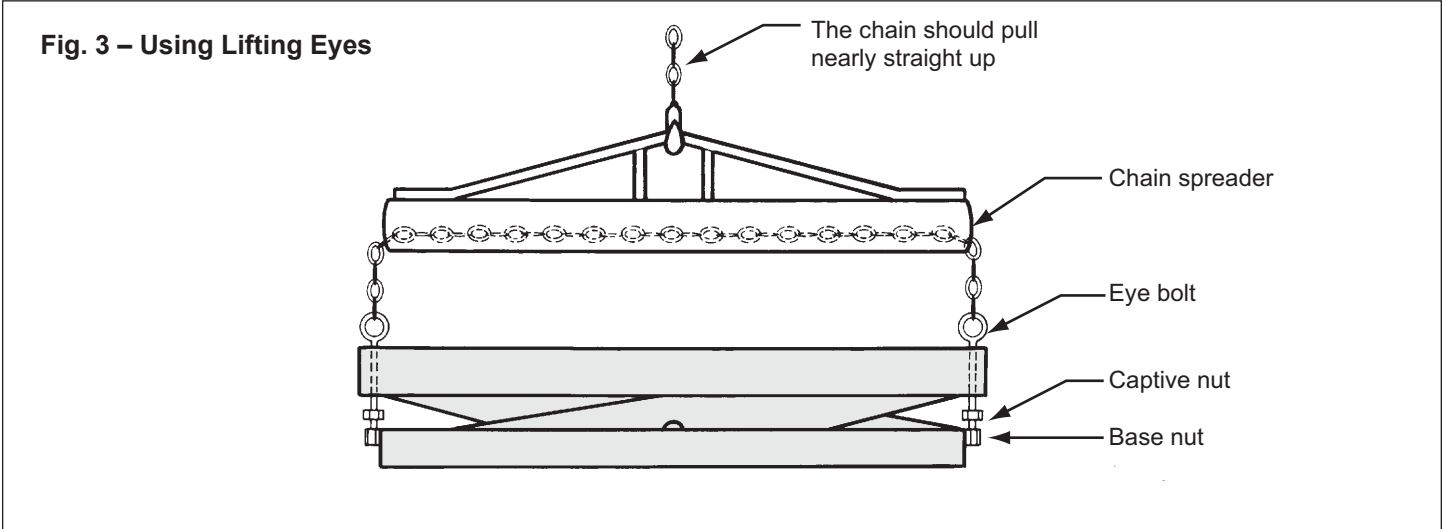

Fig. 3 – Using Lifting Eyes

5. If the power unit is mounted within the lift (“internal power unit”), you will need these tools:

- A crane or lift truck that can lift the unit safely.
- Shims and lag bolts – see the pit plan if the lift will be mounted in a pit.
- A masonry drill and bit to drill the holes for the lag bolts.
- A power supply with the specified voltage, including fuses or circuit breakers as specified in Figs. 11 and 12.

If the power unit will be mounted away from the lift (“external power unit”), you will also need:

- A compressed air source for clearing the hydraulic lines.
- Extra hydraulic oil for flushing the underground lines and refilling the tank. See Table 2 for the oil specifications.

Positioning the Lift

6. Remove the shipping material and unskid the lift. On the front of this manual, confirm the model number, serial number, and date the lift is placed in service. You can find the model number and serial number on the name plate. The name plate is located on the crossbar at the base of the cylinders.

7. Move the lift into position, supporting the base of the lift. Install the lift as shown in Fig. 2. Unless the lift is mounted on casters, lag the lift to the floor.

⚠ CAUTION

Do not hang the lift from the table top. This can damage the lift.

⚠ WARNING

If the lift is mounted on an unstable surface, it may tip over when it is in use. You may be hurt, and the lift and load may be damaged.

If your lift has lifting eyes, as shown in Fig. 3, use these when you move the lift. It is best to use a chain spreader, so the chain sections pull straight up. (You must supply the chain and spreader.) Remove the lifting eyes once you have moved the lift.

Hydraulic Connections

(External Power Units Only – If Internal Power Unit, proceed to step 10.)

8. Install the power unit. Install the hydraulic line between the power unit and the lift as shown on the pit plan.

9. Blow out the hydraulic line with compressed air before connecting it to the power unit. Replace the solid plug on the hydraulic fluid tank with the vented plug supplied, then attach the vent line to the vented plug.

⚠ WARNING

Be sure that the hydraulic line will not be pinched by the lift as it raises or lowers. If you allow the line to be pinched, the lift may not work properly. A hose may break, the lift table may drop suddenly, and someone may be hurt.

⚠ CAUTION

It is very important to keep the hydraulic oil free of dirt, dust, metal chips, water, and other contamination. Most of the problems with hydraulic systems are

Table 1 – Hydraulic Oil Specifications

If the lift will be used at normal ambient temperatures, Presto supplies the unit with CONOCO 32 oil. This may be replaced by any other good quality oil with 150 SSU at 100° F and rust and oxidation inhibitors and anti-wear properties.

If the lift will be used at ambient temperatures below 0°F, use aircraft hydraulic oil. Use Type 15 aircraft hydraulic oil.

The following are equivalent to CONOCO 32:

TYPE	MANUFACTURER
DTE 24	EXXON/MOBIL
NUTO H32	EXXON/MOBIL
AMOCO AW32	CHEVRON (AMOCO CO.)

⚠ CAUTION

It is very important to keep the hydraulic oil free of dirt, dust, metal chips, water, and other contamination. Most of the problems with hydraulic systems are caused by contamination in the oil.

caused by contamination in the oil. Be sure to flush all hydraulic lines before connecting remote power units.

⚠ CAUTION

If you do not install the vented plug in the tank, the pump may be damaged.

Electrical Connections

⚠ DANGER

The lift may use a power supply of up to 575 Volts AC. This voltage can kill you. Don't work with the electrical parts unless you are a qualified electrician.

10. Make temporary electrical connections to the lift, as shown in Fig. 11 (for single-phase AC) or Fig. 12 (for three-phase AC). This temporary set-up will allow you to raise the lift.

⚠ WARNING

The fusing requirements are shown in Table 1. To avoid fire danger, follow these requirements.

11. On a lift designed for three-phase AC, you must be sure the pump motor is turning in the right direction. The lift table should start to move quickly when you press the "up" or "down" button. If the lift table does not move in 2 or 3 seconds, don't try to operate the lift! Exchange any two of the three-phase leads. If this does not correct the problem, see the troubleshooting instructions at the end of this manual.

⚠ CAUTION

If you have a unit designed for three-phase AC and you connect the power so the motor runs backwards, the lift will not operate, and you may damage the pump. Do not operate the lift for more than 2 or 3 seconds if you think the motor might be turning backwards.

12. **Raise and chock the lift**, as shown in Fig. 1.

13. Make the permanent electrical connections as shown in Fig. 11 (for single-phase) or Fig. 12 (for three-phase).

14. Check the level of the hydraulic fluid. On most models, when the lift is fully elevated, the oil should be about 3/4 above the bottom of the tank. Use a dipstick to check the oil level, and add oil as necessary.

Testing

15. Clear the area around the lift. Remove any loose wires, lumber, or other materials which might get in the way of the lift as it raises or lowers.

16. Remove the maintenance chocks and warn others to stay away from the lift. Operate the lift through its full range of travel. The lift should rise smoothly with a quiet humming sound, and lower smoothly and quietly. Raise and lower the lift a few times to check the clearances around the lift table.

⚠ WARNING

As the lift table moves up and down, "pinch points" are created at the places shown in Fig.

Fig. 4 – Center the Load

Always place the load in the center of the lift table

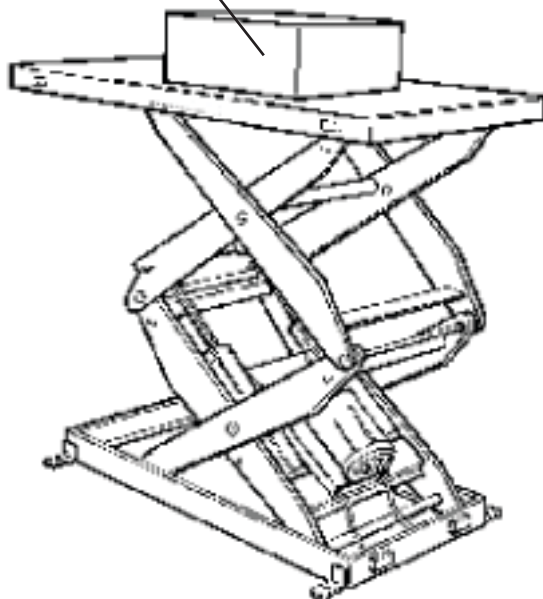
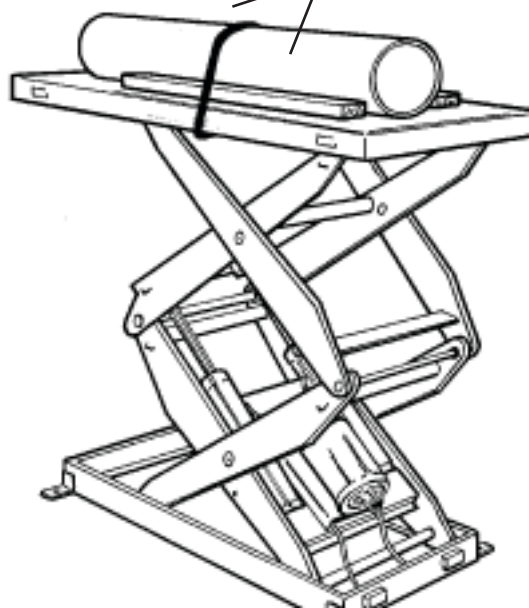

Fig. 5 – Secure the Load

If the load can roll or move, insert chocks, or fasten the load down



6. If you are standing too close to the lift when it is moving, your arm or leg may be caught in the moving parts, and you may be hurt. Stay away from the pinch points when the lift is moving.

Completing Installation

17. If your lift is mounted in a pit, align the unit with the sides of the pit. Once you are sure the lift is positioned correctly, mark the locations of the lag holes in the base frame, and drill the holes. If necessary, insert metal shims to level the base of the lift. Insert and tighten the lag bolts to secure the lift. Grout under the base rails to prevent vibration and distortion of the base frame, as shown in Fig. 2.

18. If the lift is lowering too quickly or too slowly, you can change the “down speed” by adjusting the flow control.

⚠️ WARNING

When adjusting the flow control, always raise the lift table and insert the maintenance chocks, as shown in Fig. 1. Don't try to adjust the flow control while pressing the “down” button. If you try this, the lift table may drop suddenly, and you may be hurt.

It is important that you follow these steps when adjusting the flow control:

- **Raise the lift table and chock the legs**, as shown in Fig. 1.
- If you want the lift to lower more slowly, turn the control clockwise up to 1/4 turn at a time. If you want the lift to lower more quickly, turn the control counterclockwise up to 1/4 turn. Don't move the control more than 1/4 turn at a time.
- Remove the maintenance chocks, and check the descent speed.
- Every time you want to change the adjustment again, raise the table again and insert the chocks as shown in Fig. 1.

19. Test the lift with the rated load. If the lift does not rise, and you hear a loud squealing noise, the pressure relief valve is operating. Contact Presto-ECO for instructions.

⚠️ WARNING

Don't continue to use the lift if this happens. The pump will overheat very quickly, and may be permanently damaged. Do not try to adjust the relief valve. If you change the setting on the relief valve, you may overwork the lift. This can cause the lift to fail suddenly, and you may be hurt.

20. As a final step, clean up all spilled hydraulic fluid. Spilled hydraulic oil is slippery, and may present a fire hazard. If you clean up any spilled fluid, you will be able to tell immediately if the lift begins to leak.

OPERATING INSTRUCTIONS

Operating Procedure

1. Before operating the lift, read and understand this entire section. Also read and understand the inserted information on optional modifications and accessories.

⚠️ DANGER

The lift may use a power supply of up to 575 Volts AC. This voltage can kill. Don't work with the electrical parts unless you are a qualified electrician!

2. If the lift is on casters, place it on a firm, flat surface as shown in Fig. 2. Stationary lifts should be lagged to the floor.

⚠️ WARNING

If you place the lift on a soft surface, it may tip over, especially when it is loaded or raised. Someone may be hurt, and the lift and load may be damaged.

3. Load the lift correctly.
- Be sure that the load weighs no more than the maximum rated for the lift. The maximum rated load is shown on the platform skirt.

⚠️ WARNING

Don't try to lift a load that exceeds the maximum rating. If you try this, the lift may fail suddenly. Someone may be hurt, and the lift and load may be damaged.

- Place the load in the center of the lift table, as shown in Fig. 4.
 - Don't try to load the lift while the lift table is moving.
 - If you are lifting pipes or other objects which may be able to roll or move, fasten them down, or chock them as shown in Fig. 5.
4. Be sure all workers are clear of the lift. Remove any lumber or other material which may fall onto the lift.

⚠️ WARNING

Don't use the unit to lift people unless it has been specially equipped for this purpose. A specially equipped lift will include operator protection, and an excess flow protector to keep the lift from dropping suddenly if a hydraulic line is damaged. Retrofit kits are available if you want to add these features to your lift.

⚠️ WARNING

As the lift table moves up and down, “pinch points” are created as shown in Fig. 6. Stay away from these pinch points! Part of your body or clothing may become caught, and you may be hurt.

Fig. 6 – Labels and Precautionary Markings

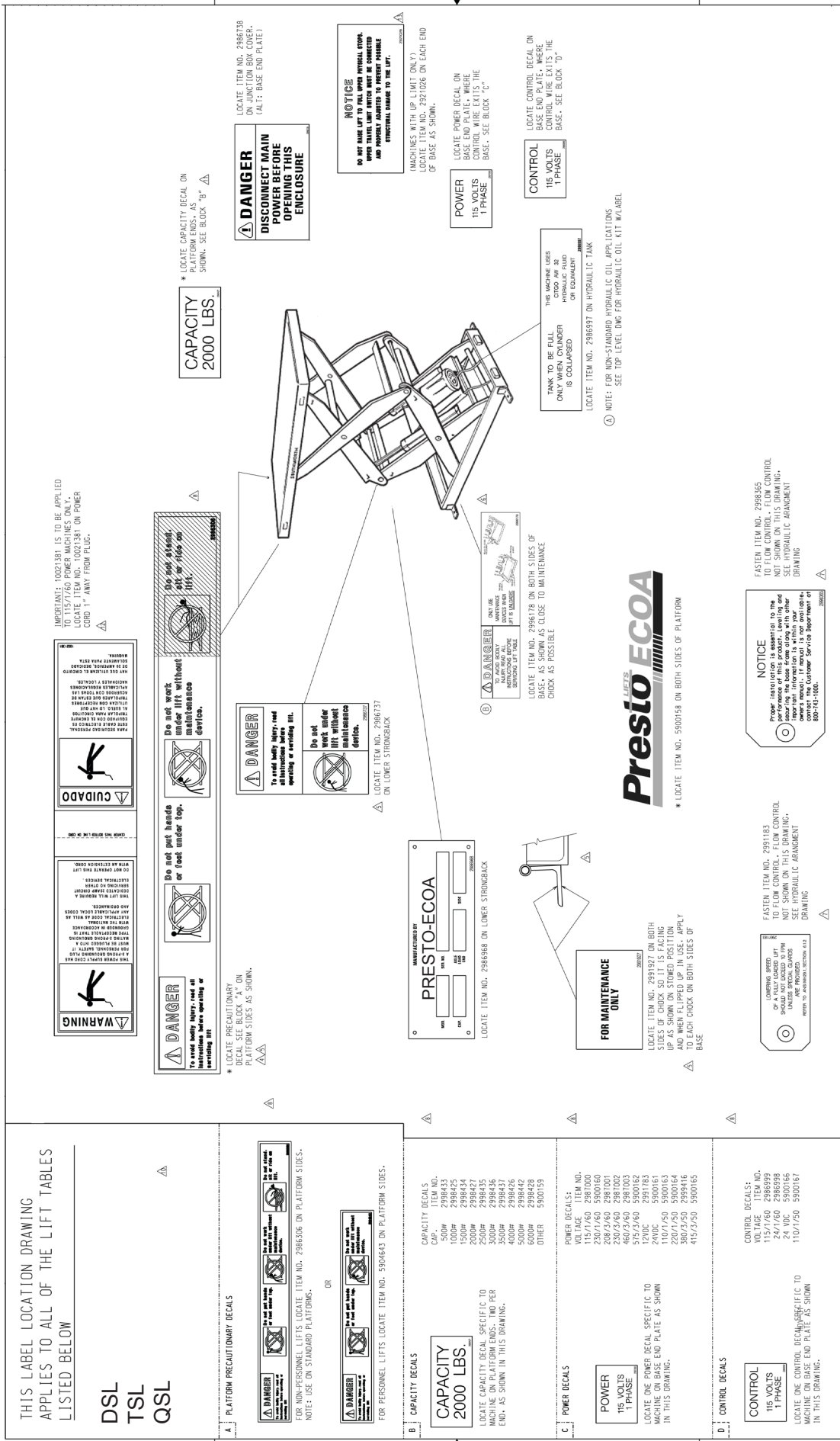

5. Operate the lift. Press and hold the “up” button to raise the lift, and “down” to lower it. Release the button when the lift reaches the limit of travel. If the lift does not operate within 2 or 3 seconds, turn off the lift and call a qualified maintenance worker.

⚠️ WARNING

If you hear a squealing noise from the pump, the pressure relief valve is operating. Don't continue to use the lift! The pump will overheat very quickly, and may be permanently damaged. The relief valve is included to protect the machine operators – don't change the relief pressure setting.

6. Wait until the lift table has stopped. Unload the lift.

⚠️ WARNING

The warning labels on the lift are there for your safety. If you find that the labels are worn or missing, or have been painted over, ask Maintenance to replace the labels before you use the lift. The labels are shown in Fig. 7.

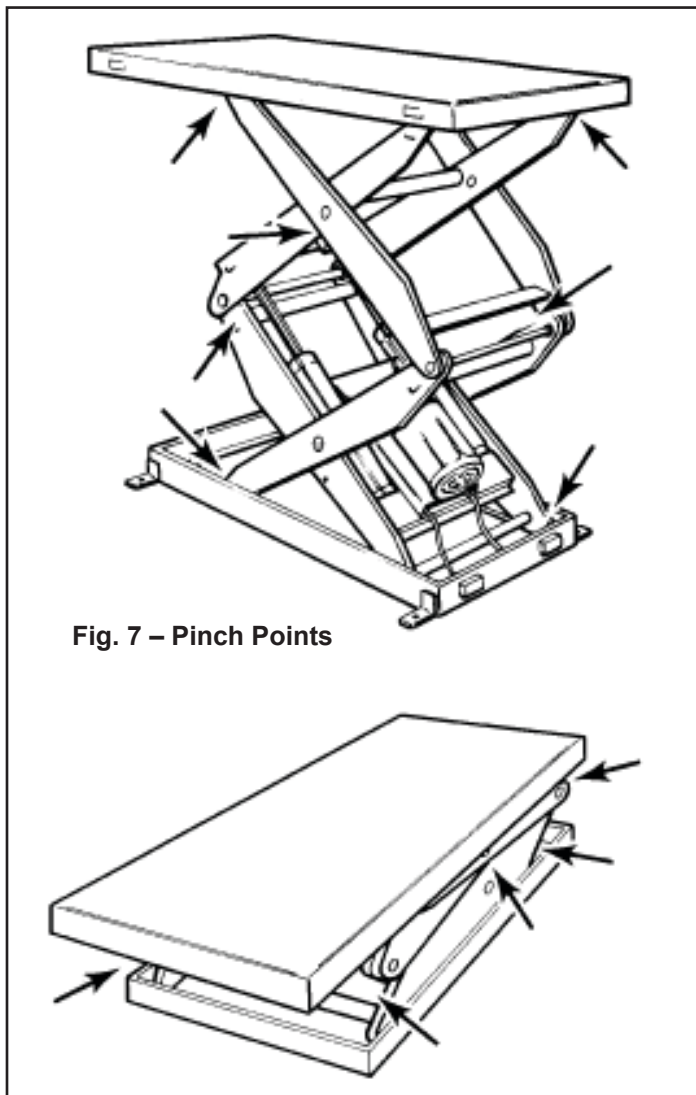

Fig. 7 – Pinch Points

SECTION 5 MAINTENANCE

Generally, the scissor lifts require very little maintenance. Reasonable care will result in excellent trouble-free performance.

⚠️ WARNING

Never go under or service lift with a load on the table or with the scissor mechanism unblocked. Always service the lift in a down position.

All servicing should be done by qualified personnel. Qualified personnel should be able to read and understand wiring and hydraulic diagrams. They should be able to troubleshoot live electrical circuits safely and in accordance with accepted practice. **For safety's sake**, if in doubt, please contact your dealer or Presto/ECO Customer Service Department at (800) 343-9322. Before servicing the lift, read and understand this entire section and the section entitled “Operating Instructions.”

Hazards

There are several hazards you should be aware of as you service the lift:

⚠️ DANGER

The lift may use a power supply of up to 575 Volts AC. This voltage can kill. Do not work with the electrical parts unless you are a qualified electrician!

⚠️ WARNING

- As the lift moves up and down, “pinch points” are formed as shown in Figure 2. Keep hands, feet, and loose clothing away from these pinch points. If your hand or arm or a part of your clothing is caught, you may be hurt.

- A falling lift can cause severe personal injury. Before working under the lift remove any load from the platform, raise the lift and insert the maintenance devices, as shown in Figure 1. Do this every time you work under the lift!

⚠️ WARNING

Release of fluids under high pressure can cause personal injury. Before you open any part of the hydraulic system, be sure to release the hydraulic pressure.

⚠️ CAUTION

- The warning labels on the lift are there for the safety of the operators. If the labels are worn or missing, or

have been painted over, replace them before releasing the lift for operation.

⚠ WARNING

If you are going to repair the center pivot pins and bushings, you must support the lift table in a special way. Each set of leg plates, on both sides of the unit, must be clamped together firmly, using large C-clamps. You cannot use the maintenance devices shown in Figure 1 – with the pivot pins removed, they will not support the table top. If you do not support the lift table correctly, the top may drop suddenly when you remove the pivot pins. Please contact Presto/ECO for instructions.

NOTICE

It is important to use hydraulic fluid with the correct grade and properties. See the hydraulic oil specification in this manual, Table 1.

⚠ WARNING

If a hydraulic fitting becomes loose, or if a hydraulic hose breaks, the hydraulic fluid may escape from the system under pressure. If the lift is raised when this happens, it can drop quickly. Someone may be hurt, or the lift or load may be damaged.

NOTICE

If you continue to use fluid after it has “worn out,” the moving parts in the system will wear more quickly.

If the lift will not raise:

NOTICE

Do not continue to hold the “up” button for more than 2 or 3 seconds. You may damage the pump.

⚠ WARNING

Do not change the relief valve setting. This valve has been included for the protection of workers who install, use, or service the lift. If it is ever necessary to repair or reset the valve, contact Presto/ECO for instructions.

⚠ WARNING

It maybe necessary to electrically by-pass the up limit switch to place the lift on the chocks. Ensure that doing so will not operate the switch beyond its arms physical limits. This needs to be done by qualified

maintenance personnel. If electrical by-pass is not possible the up limit switch needs to be moved in order to place the unit on the maintenance devices, then the lift platform and legs will need to be supported before working on the switch, support the top and leg sets with a crane, fork truck or blocking from the floor to table top. Ensure switch is properly reinstalled any any electrical by-pass is removed before operating the lift. Any final adjustment of limit switch needs to occur with the legset and platform supported while working under the lift. If you do by-pass or remove the switch, when the lift platform moves up, it may not stop at the correct point. If the platform rises above the normal stopping point, the frame of the unit may be damaged. People working nearby may be hurt.

NOTICE

If cavitation is allowed to continue, the pump may be damaged, and may have to be replaced.

If the lift elevates, but fails to hold a load:

⚠ WARNING

Failure to insert the maintenance devices may result in damage to the lift and severe personal injury!

If the lift fails to lower:

⚠ WARNING

Failure to insert the maintenance devices may result in damage to the lift and severe personal injury!

⚠ DANGER

Do not try to adjust the flow control while pressing the “down” button. If you try this, the lift table may drop suddenly, and you may be hurt.

TROUBLESHOOTING

PROBLEM	POSSIBLE CAUSE	CHECK THIS
Lift will not raise	Weight of load too heavy	Check the actual weight of the load
	Motor not running	Check the main disconnect switch, fuses, and wiring to the motor. A 20 amp, designated braker must be supplied for 110V
	Hydraulic oil level low	When lift is raised as far as possible, oil level should be 3/4" from bottom of tank. When lift is down, 3/4" from top
	Lift has reached its upper limit	Upper limit switch may need to be adjusted
	Motor may be "single phasing"	If motor hums but does not turn, check motor wiring and line fuses.
	Motor voltage too low	Supply voltage should be +/- 10% of the rating at the motor terminals.
	Tank vent plugged	If supplied, remove solid plug from tank, insert vent plug.
	Suction filter clogged	Clean suction filter as described in periodic maintenance
	Vacuum leak in suction line	Check all fittings in suction line
	Down valve may be energized	Check wiring to down valve, and solenoid in the valve
	Missing coupling	Check to insure the coupling has been installed between the pump and motor
The lift fails to hold	Down valve may be leaking	Remove down valve and inspect for debris which may be preventing it from closing.
	Down valve may be energized	Check the solenoid in the valve with a volt meter.
	Cylinder may be leaking	Check for oil in cylinder in the vent line.
Lift will not lower	Down valve may be de-energized	Check the solenoid in the valve with a volt meter
	Flow control needs adjustment	Adjust flow control as needed
Lift raises too slowly	Voltage may be low	Check voltage at motor to ensure proper voltage is being supplied
	Foreign material clogging suction filter, breather cap or pressure line	Remove necessary components and clean
	Pump may be overheating due to insufficient oil	Check oil level and oil viscosity
Lift lowers too slowly	Down valve may not be fully open or stuck closed	Remove down valve and clean
	Flow control may need adjustment	Adjust flow control as needed

TROUBLESHOOTING WARNINGS

All servicing should be done by qualified personnel. Qualified personnel should be able to read and understand wiring and hydraulic diagrams. They should be able to troubleshoot live electrical circuits safely and in accordance with accepted practice. **For safety's sake**, if in doubt, please contact your dealer or Presto-ECO.

Before servicing the lift, **read and understand this entire section and the section entitled “Operating Instructions.”**

⚠ WARNING

Before working underneath the lift, always raise the lift and insert the maintenance devices, as shown in Figure 1. Failure to do so may result in damage to the lift and severe personal injury!

If the lift will not raise:

⚠ CAUTION

Do not continue to hold the “up” button for more than 2 or 3 seconds. You may damage the pump.

⚠ WARNING

Do not change the relief valve setting. This valve has been included for the protection of workers who install, use, or service the lift. If it is ever necessary to repair or reset the valve, contact customer service. for instructions.

⚠ WARNING

Do not disconnect the up limit switch. Instead, loosen the adjusting screw, and change the position of the arm. If you do disconnect the switch, when the lift platform moves up, it may not stop at the correct point. If the platform rises above the normal stopping point, the frame of the unit may be damaged. People working nearby may be hurt.

CAUTION!

If cavitation is allowed to continue, the pump may be damaged, and may have to be replaced.

If the lift elevates, but fails to hold a load:

⚠ WARNING

Failure to insert the maintenance devices may result in damage to the lift and severe personal injury!

If the lift fails to lower:

⚠ WARNING

Failure to insert the maintenance devices may result in damage to the lift and severe personal injury!

⚠ DANGER

Do not try to adjust the flow control while pressing the “down” button. If you try this, the lift table may drop suddenly, and you may be hurt.

ORDERING REPLACEMENT PARTS

Presto-ECOALifts has carefully chosen the components in your unit to be the best available for the purpose. Replacement parts should be identical to the original equipment. Presto-ECOALifts will not be responsible for equipment failures resulting from the use of incorrect replacement parts or from unauthorized modifications to the unit.

Presto-ECOALifts can supply all replacement parts for your lift. With your order, please include the model number and the serial number of the unit. You can find these numbers on the name plate. This plate is located within the scissors mechanism.

To order replacement parts, please call the Presto-ECOALifts Parts Department. Parts are shipped subject to the following terms:

- FOB factory
- Returns only with the approval of our parts department.
- Credit cards preferred (except parts covered by warranty).
- Freight collect for truck (except parts covered by warranty).
- Freight – prepaid and invoice for small parcel shipments (except parts covered by warranty).
- The warranty for repair parts is 30 days from date of shipment.

Parts replaced under warranty are on a “charge-credit” basis. We will invoice you when we ship the replacement part, then credit you when you return the worn or damaged part, and we verify that it is covered by our warranty. Labor is not covered under warranty for Parts orders.

Presto-ECOALifts Parts Department

50 Commerce Way, Norton, MA 02766

Telephone: 800-343-9322

FAX: 888-788-6496

Email: service@PrestoLifts.com

www.PrestoLifts.com

www.ECOALifts.com

Electrical Connections for Single-Phase AC

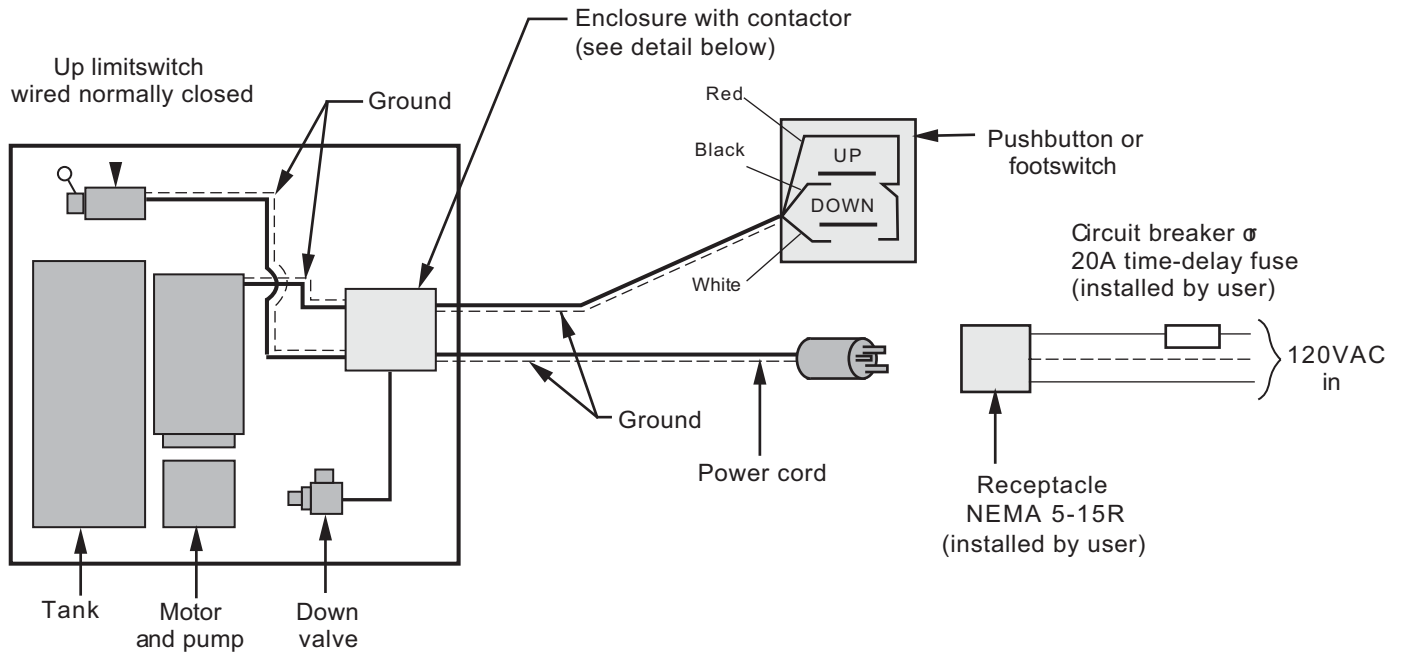
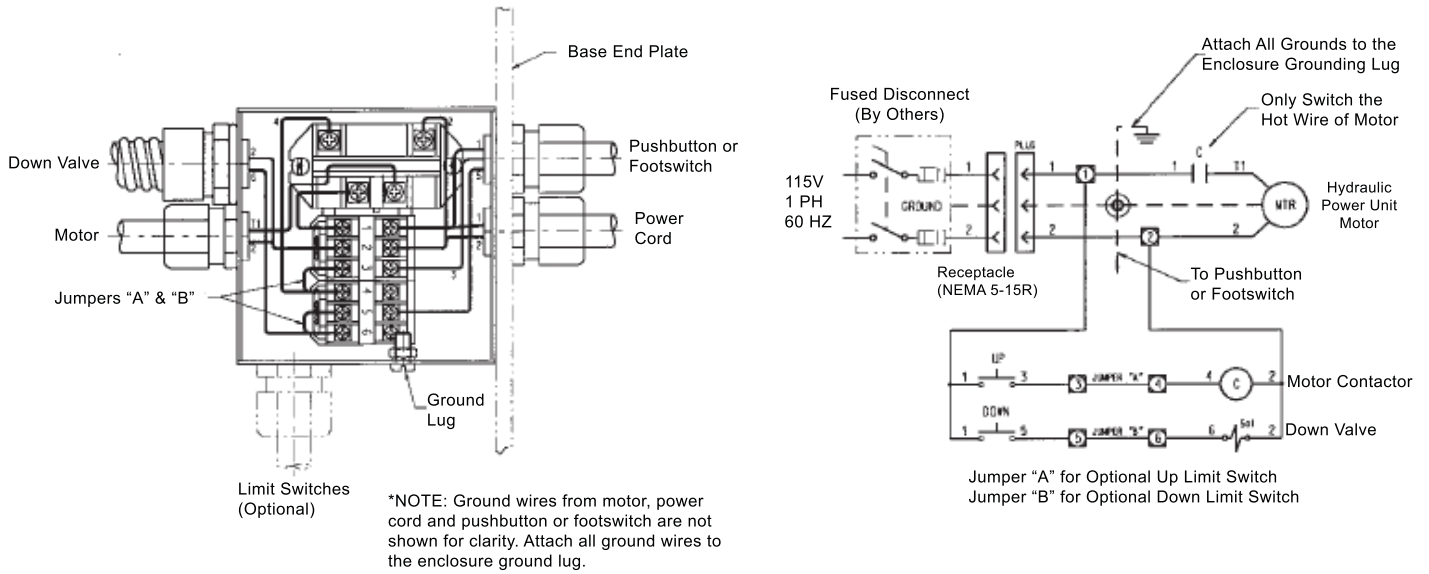

Fig. 11 – Electrical Connections, Lifts Wired for Single-Phase AC

If your lift has a dual-voltage motor, determine the correct voltage and make the connections as shown on the nameplate. Connections shown above are for lifts operating on 120 VAC. For lifts operating on 230 VAC, a NEMA L6-15R receptacle is required. The pump, motor, and down valve may be mounted on the lift unit itself (internal power unit) or in a separate location (external power unit). The pump has a built-in relief valve and check valve. The down speed control is pressure-compensated.

Fig. 12 – Wiring Diagram, Lifts Wired for Single-Phase AC – with limitswitch



208/230/460V-3PH60Hz
Supply voltage
(from fused disconnect)

Note: Ground connections not shown.
For ground connections use
supplied grounding terminal.

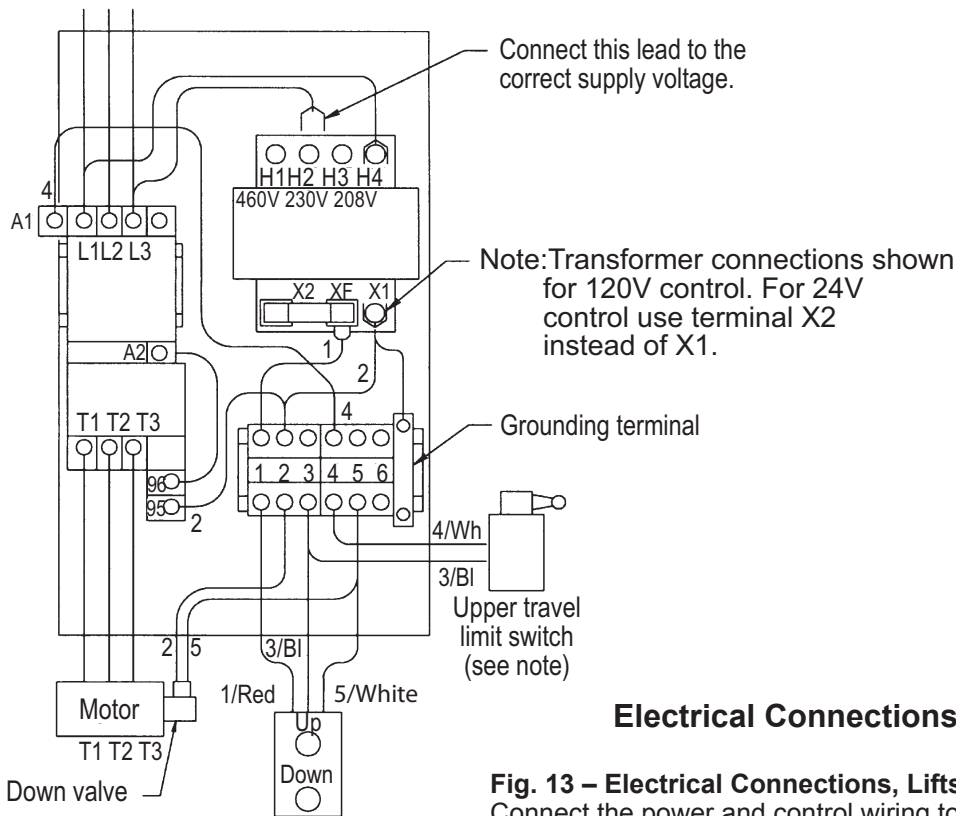

Electrical Connections for Three-Phase AC

Fig. 13 – Electrical Connections, Lifts Wired for Three-Phase AC
Connect the power and control wiring to the proper terminals located in the control panel. The pump, motor and valve may be mounted on the lift unit itself (internal power unit) or in a separate location (external power unit). The control panel may be wall mounted.

CAUTION

If on power-up the motor rotates in the wrong direction, don't continue to operate the lift. You may damage the pump. To correct the problem, interchange any two of the motor leads (T₁, T₂ or T₃).

Fig. 14 – Schematic, Lifts Wired for Three-Phase AC

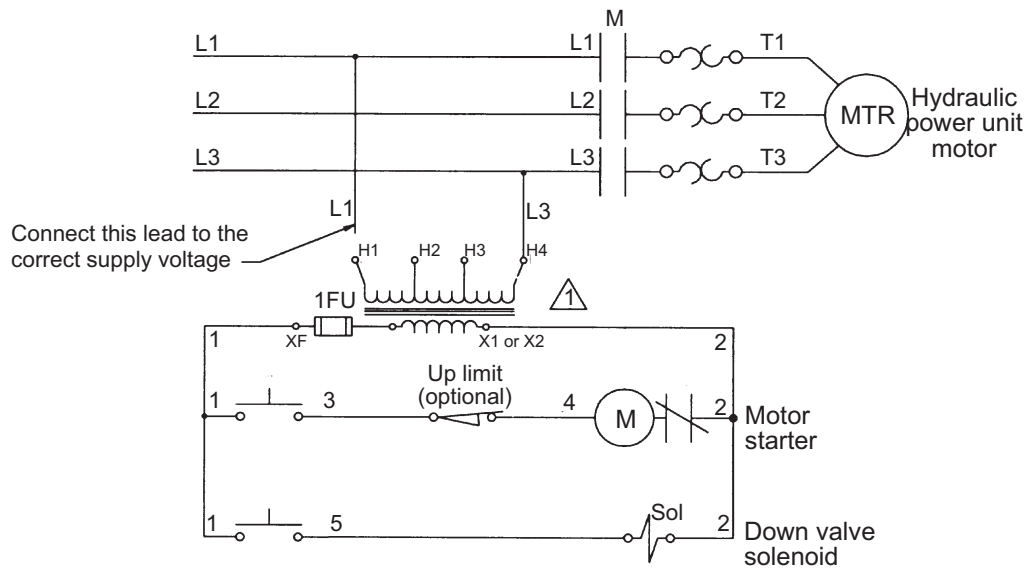

Note: Upper travel limit switch is optional.
If limit switch is absent, move wire 4 in panel from terminal 4 to terminal 3 and renumber as wire 3.

Fig. 15 – Hydraulic Connections

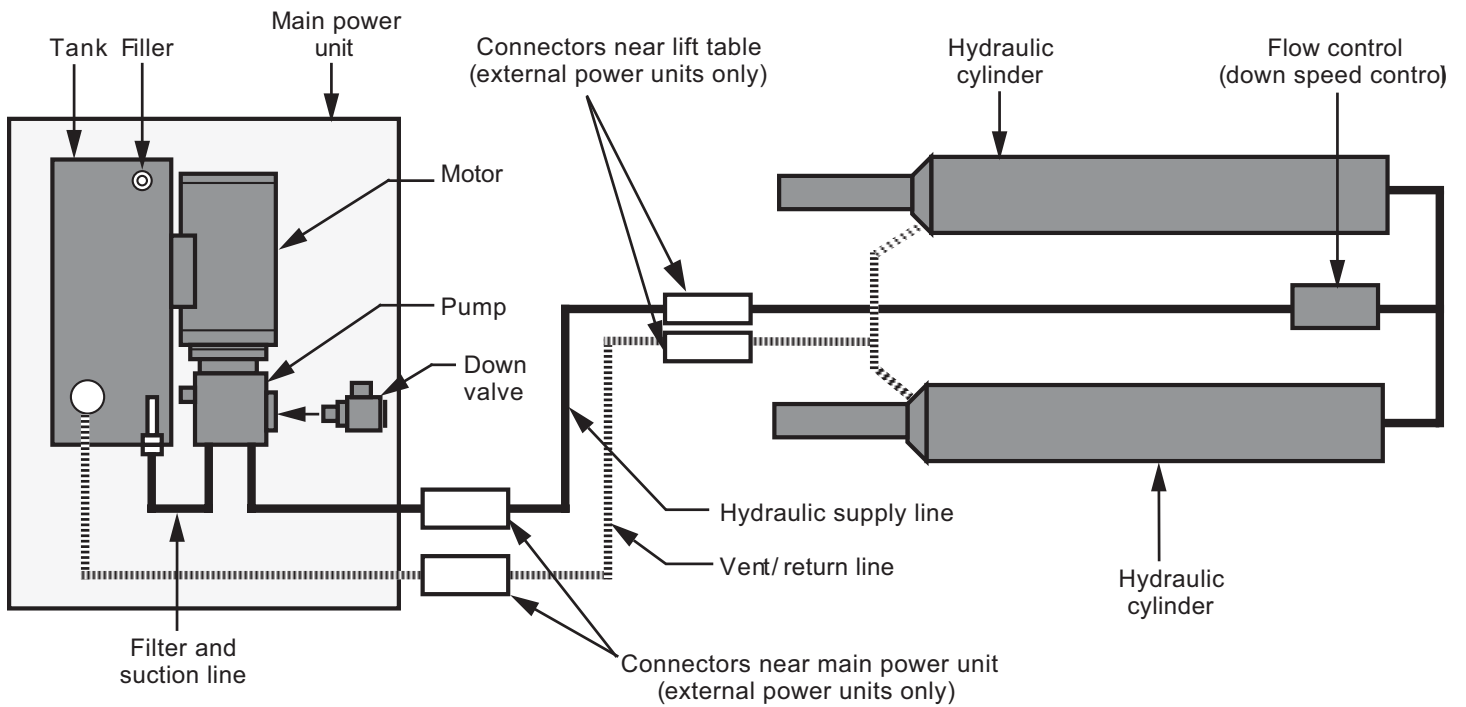

Fig. 16 – Hydraulic Diagram

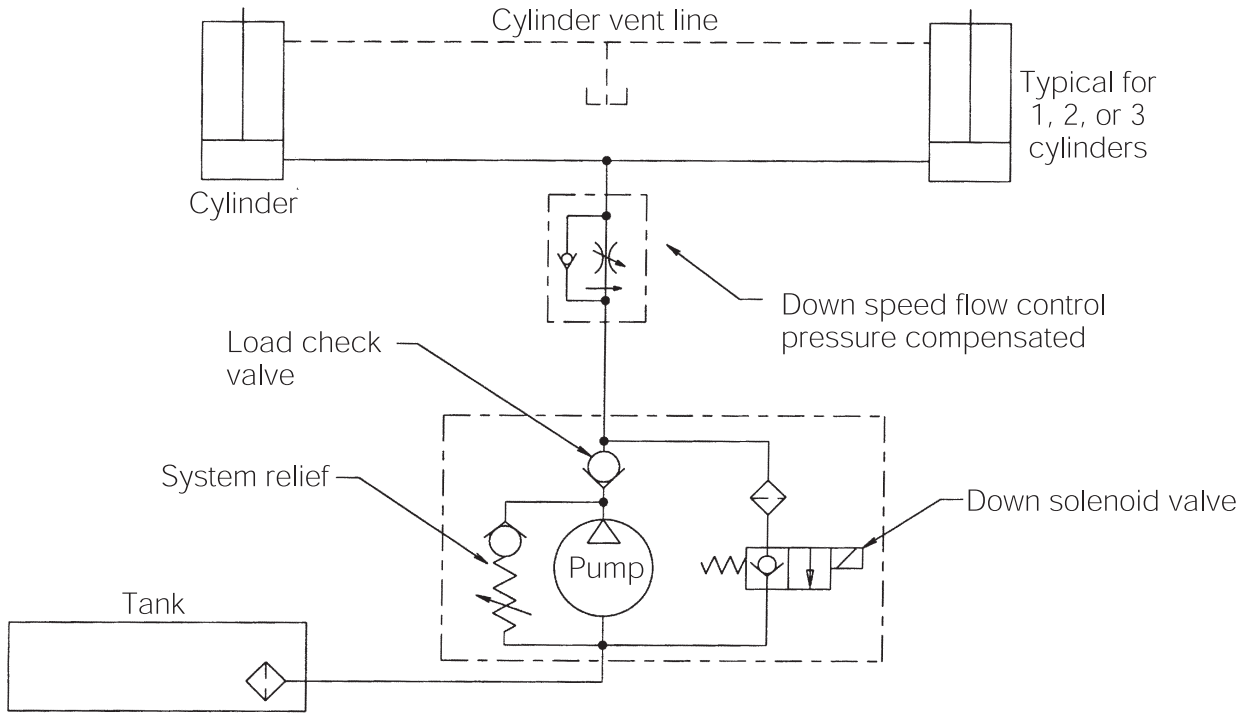

Table 2 – Electrical Interface, Supplied by Customer

Motor Voltage	Required Fuse 1.0 HP Motor	Required Fuse 3.2 HP Motor	Wire Gauge
120/1/60	20 AMP	—	12 AWG
208/1/60	20 AMP	—	12 AWG
240/1/60	20 AMP	—	12 AWG
208/3/60	10 AMP	12 AMP	14 AWG
240/3/60	10 AMP	10 AMP	14 AWG
480/3/60	5 AMP	5 AMP	14 AWG
575/3/60	5 AMP	5 AMP	14 AWG

Presto-ECO Lifts Limited Warranty Policy

Presto-ECO Lifts warrants all of its products against defects in the welded structural frame and, if applicable, scissor legs from faulty material and workmanship for a period of five years from the date of invoice.

All other components have a limited warranty against defects in faulty material and workmanship for a two year period from the date of invoice date of invoice and 30 day limited warranty on labor. Please note that prior authorization from Presto-ECO Lifts is required on all warranty work.

There are no implied warranties of any kind, more specifically, there are no warranties of merchantability or fitness for any particular purpose. Presto-ECO Lifts' sole warranty shall be as set forth in this limited warranty.

Presto-ECO Lifts will elect to repair or replace a defective component without charge, if any components should become defective within the limited warranty period. Proof of purchase is required for warranty. The charge for shipping the defective component is the responsibility of the buyer and must be accompanied with an RMA number. The shipping charge to return the component to the buyer is the responsibility of Presto-ECO Lifts.

This limited warranty does not cover labor expense for removal or reinstallation of components after thirty days. This limited warranty shall not cover, among other things: damages resulting from foreign matter or water, failure to provide reasonable and necessary maintenance, and if applicable, use of product while charger is plugged into an AC outlet, or failure to follow operating instructions. The limited warranty is not valid for damage resulting from negligence, accident, unreasonable use, abuse or misuse, exceeding data plate capacities or altering the product without Presto-ECO Lifts authorization.

Presto-ECO Lifts expressly disclaims and excludes any liability for consequential, incidental, indirect or punitive damages or financial loss to people or property resulting from any breach of warranty or the operation or failure of this product.

Presto-ECO Lifts makes no representation that this product complies with local, state, or federal safety/product standards codes. Should this product fail to comply in any way with those codes, it shall not be considered a defect of materials or workmanship. Presto-ECO Lifts shall not be held liable for any damages resulting from noncompliance. It is the dealer's responsibility to exercise this limited warranty. This limited warranty is provided to the original purchaser (defined as the original end user) and is nontransferable. This constitutes the complete and final agreement involving Presto-ECO Lifts limited warranty obligations for products.