

DBP Series Scissor Lifts

Installation, Operation and Service Manual

Model Number _____

Serial # _____

Date placed in service _____

IMPORTANT: READ CAREFULLY
BEFORE INSTALLING OR OPERATING LIFT

Part orders are subject to a \$50 minimum charge.



This manual was current at the time of printing. To obtain the latest, most updated version, please contact Presto Lifts Customer Service Department or go to our website: www.PrestoLifts.com -- you will find a complete list of current owner's manuals to print.

CONTENTS

SECTION 1:	
Introduction.....	4
Responsibility of Owners and Users.....	5
Safety Alert Symbols and Signal Words.....	6
SECTION 2:	
Safety	7
SECTION 3:	
Installation.....	7-8
A. Uncrating and Inspection	
B. Installing	
C. Electrical	
D. Hydraulics	
E. Testing the Lift with No Load	
SECTION 4:	
Operation.....	8-9
A. Method of Operation	
B. Operating Instructions	
SECTION 5:	
Battery Maintenance	9-10
SECTION 6:	
Maintenance.....	10
A. Routine Maintenance	
B. Troubleshooting Maintenance	
SECTION 7:	
Service.....	11
A. Replacing Cylinder Seals	
SECTION 8:	
Troubleshooting	12
RESTOCKING POLICY	20
ORDERING REPLACEMENT PARTS	21
RETURN GOODS AUTHORIZATION POLICY	22
WARRANTY	23

LIST OF FIGURES:

DBP Product Illustration (Figure 1)	13
Electrical Schematic for 12 Volt DC DBP (Figure 2).....	14
Hydraulic Pump (Figure 3)	15
Hydraulic Arrangement DBP Series (Figure 4).....	16
Electrical Arrangement DBP Series (Figure 5).....	17
ACP PORTABLE KIT CASTER for DBP Series (Figure 6).....	18
Labels and Locations (Figure 7).....	19

SECTION 1

INTRODUCTION

This manual attempts to provide all of the information necessary for the safe and proper installation, operation and maintenance of Presto Lifts Inc.'s DBP Series DC Electric Scissor Lifts. It is important that all personnel involved with the installation, maintenance or operator of the scissor lift read this manual. Where unique situations arise, that are not covered in this manual call Presto Lifts for further instructions. Additional manuals are available upon request or on our web site at www.prestolifts.com.

The scissor lift has a nameplate that provides the load capacity ratings, serial number and model identifications. Please refer to these numbers when ordering parts or requesting further information.

The Presto Lifts DBP Series DC Electric Scissor Lifts are designed for lifting, lowering and positioning a variety of loads. WHERE UNIQUE SITUATIONS ARISE, THAT ARE NOT COVERED IN THIS MANUAL, CALL PRESTO LIFTS FOR FURTHER INSTRUCTIONS.

The DBP Series DC Electric Scissor Lifts is designed for in plant/nonhazardous location use only. These units are not for personnel lifting.

Responsibility of Owners and Users

Inspection and Maintenance

The device shall be inspected and maintained in proper working order in accordance with Presto's owner's manual.

Removal from Service

Any device not in safe operating condition such as, but not limited to, excessive leakage, missing rollers, pins, or fasteners, any bent or cracked structural members, cut or frayed electric, hydraulic, or pneumatic lines, damaged or malfunctioning controls or safety devices, etc. shall be removed from service until it is repaired to the original manufacturer's standards.

Repairs

All repairs shall be made by qualified personnel in conformance with Presto's instructions.

Operators

Only trained personnel and authorized personnel shall be permitted to operate PowerStak.

Before Operation

Before using the device, the operator shall have:

- Read and/or had explained, and understood, the manufacturer's operating instructions and safety rules.
- Inspected the device for proper operation and condition. Any suspect item shall be carefully examined and a determination made by a qualified person as to whether it constitutes a hazard. All items not in conformance with Presto's specification shall be corrected before further use of the PowerStak.

During Operation

The device shall only be used in accordance with this owner's manual.

- Do not overload.
- Ensure that all safety devices are operational and in place.

Modifications or Alterations

Modifications or alterations to any Presto industrial positioning equipment shall be made only with written permission from Presto.

SAFETY ALERT SYMBOLS AND SIGNAL WORDS

The safety of all persons operating, maintaining, repairing, or in the vicinity of this equipment is of paramount concern. This is a powerful machine with moving parts, and is capable of causing personal injury if proper precautions are not taken. Therefore, throughout this manual, certain hazards have been identified which may occur in the use of the machine, and there are appropriate instructions or precautions which should be taken to avoid these hazards. In some cases, there are consequences which may occur if instructions or precautions are not followed. Below are the symbols and signal words along with their definitions referenced from ANSI Z535.4 - Product Safety Signs and Labels.

Safety Alert Symbols

These are the safety alert symbols.. They are used to alert you to potential physical injury hazards. Obey all safety messages that follow this symbol to avoid possible injury or death.



For use with DANGER signal word
(Red Background)



For use with WARNING signal word
(Orange Background)



For use with CAUTION signal word
(Yellow Background)

Signal Words

The meaning of different signal words as defined by ANSI Standard Z535.4 indicates the relative seriousness of the hazardous situation.



(Red Background)

DANGER indicates a hazardous situation which, if not avoided, will result in death or serious injury.



(Orange Background)

WARNING indicates a hazardous situation which, if not avoided, could result in death or serious injury.



(Yellow Background)

CAUTION, used with the safety alert symbol, indicates a hazardous situation which, if not avoided, could result in minor or moderate injury.



(Blue Background)

NOTICE is used to address practices not related to personal injury.



(Green Background)

SAFETY INSTRUCTIONS (or equivalent) signs indicate safety-related instructions or procedures.

SECTION 2 **SAFETY**

The DBP Series DC Electric Scissor Lifts are very powerful lifts capable of doing large amounts of work. They contain scissor legs, that are hydraulically actuated and are capable of causing serious injury or damage if adequate precautions are not taken.

DO NOT INSTALL OR OPERATE THESE LIFTS WITHOUT CAREFULLY READING THIS MANUAL. In order to provide for the safe operation of these scissor lifts, Presto Lifts Inc. has identified certain hazards that may occur during the installation, maintenance and use of these lifts. **For safety reasons the standard DBP Series DC Electric Scissor Lifts are designed to be serviced or repaired in the lowered position.** If performed properly, this will greatly reduce the possibility of injury. Lifts with oversize table tops require special handling (See Section 5, Maintenance).

⚠ WARNING

- ↑ Do not perform any repair work on lifts if there is a load on the platform or with the table in a raised position.
- ↑ All personnel must stand clear of the lift when the lift is in motion.
- ↑ Do not put hands or feet under the lift table.
- ↑ Do not work under the table without securing the lift with supplied safety chocks.
- ↑ Do not stand, sit or climb on the lift.
- ↑ Do not use the lift on soft, uneven or unstable surfaces.
- ↑ Do not exceed the load capacity.
- ↑ Do not place a load on a moving lift.
- ↑ Place loads in the center of the table and secure loads properly.

SECTION 3 **INSTALLATION**

A. UNCRATING AND INSPECTION:

Upon receipt of the DBP Series DC Electric Scissor Lifts, inspect the equipment completely to determine if there is any shipping damage, and that the lift is complete. Presto Lifts Inc. tests and inspects every piece of equipment prior to shipment. If damage is apparent, a freight claim must be filed with the freight company. Do Not use the lift if there appears to be any damage. With the lift in a collapsed position, check the following:

⚠ CAUTION

Lifts with oversize table tops must not be over extended since doing so may disassociate the cylinder base from its socket. (See Section 5, Maintenance).

- ↑ Check for signs of damage especially to the electrical and hydraulic components.
- ↑ Check all connections for tightness.
- ↑ Check for any bent or damaged metal parts.
- ↑ Check base frame for flatness.

⚠ CAUTION

When moving the lift, do not attempt to pick it up by the table top. The lift should be picked up by its base only.

B: INSTALLING:

Before starting, be sure that the battery is connected. Read all of the instructions prior to starting the lift.

1. Handle Assembly

- a). Portable lifts have the push handles removed for ease of shipping. Handles should be inserted in the holders until they bottom out then tighten set screws on each holder with an Allen wrench.

C. ELECTRICAL:

1. The motors on DBP Series DC Electric Scissor Lifts are special intermittent duty motors with high pull up torques. These motors require heavier duty electrical controls than standard motors.

⚠️ WARNING

Do not attempt to modify or change the electrical circuit. Any alterations will cause damage to the pump and possible physical injury. Only authorized personnel should service the electrical system.

2. For the DBP Series DC Electric Scissor Lifts, a battery charger is furnished with a short AC 120 plug. A circuit of 15 amps or larger will suffice to operate the battery charger.

D. HYDRAULICS:

1. Use only hydraulic oil for the lift. The lift has been supplied with Conoco Super Hydraulic 32. When adding fluid, use only the recommended oils.
2. Before using the lift, check the hydraulic oil level and add oil if necessary. Check fittings for tightness. Remove the solid plug on the reservoir and replace it with the vented plug provided. If the plug is not installed, you may damage the pump.

⚠️ CAUTION

DBP Series DC Electric Scissor Lifts are designed for normal factory environments. Where below freezing conditions may exist, special fluid must be used. Contact Presto Lifts for further information when freezing conditions exist.

⚠️ WARNING

Do not use automotive hydraulic, brake or transmission fluids. They may damage seals and could pose a serious fire hazard.

E. TESTING THE LIFT WITH NO LOAD:

1. Before testing the lift, clear the area of any loose material. Be sure the lift has no obstruction above it or on any side.
2. Using the controls provided, briefly operate the lift (5-10 seconds). If the lift begins to rise with a humming sound and functions properly, continue to the full upright position.

⚠️ CAUTION

If the lift does not rise immediately, or there is any operational problem, stop it immediately. Before continuing, check the rotation of the pump and motor and the voltage at motor terminals; again briefly operate the lift. If the lift does not move smoothly with a humming sound, stop and review the procedures in the section on troubleshooting (5B).

3. After raising the lift completely, lower the lift. It should move slowly and smoothly with a humming sound. If the lift operates properly, raise and lower the lift and stop at different levels to get a good perspective on the lift's operations and movements.

SECTION 4
OPERATION

A. METHOD OF OPERATION:

Electric

All DBP Series DC Electric Scissor Lifts are provided with a special relief valve and are factory preset for the maximum safe capacity of the lift. Activating and holding the up switch will energize the motor. The motor is attached to a positive displacement pump, that draws hydraulic fluid from the reservoir and transfers it under pressure to the cylinder. This forces the piston forward and the scissor legs to separate and raise the platform, releasing the up button will stop the lift. A check valve between the pump and piston holds the table in position. Depressing and holding the down switch will energize a solenoid, that allows the oil from the cylinder to return to the reservoir through a preset flow control. This allows the lift to lower smoothly and at a controlled speed.

⚠️ CAUTION

Do not attempt to change the setting on the pressure relief valve. Do not maintain the up or down button energized if the lift fails to move or after it has reached its up or down limits. This will cause damage to the pump and controls.

B. OPERATING INSTRUCTIONS:

In order to operate the lift follow these operating procedures.

Read and understand all the instructions before operating. If the lift has modifications or accessories, read and understand their functions.

1). Load the lift correctly.

Portable lifts: Place the load on the center of the table top. The load center of gravity must be within 6" of the lift table top center and equally distributed over 80% of the table.

If the load is unstable or may become unstable, fasten it into position.

2). Operate the lift.

- a). To raise the lift, press and hold the up button.
- b). To lower the lift, press and hold the down button.
- c). Release the button to stop the lift.

3). Wait until the lift has come to a complete stop before unloading the lift.

4). Stand clear of lift when operating it in order to avoid injury.

WARNING

- a). Do not stand, sit or climb onto the lift.
- b). Do not load or unload a moving lift.
- c). If the lift fails to move or exhibits strange movements or sound, stop immediately. Do not operate the lift until it has been checked and repaired.
- d). Obey all warning labels.
- e). Do not exceed maximum rated load.
- f). Maintain load, center of gravity, within 6" of the center of the portable lift.

SECTION 5

BATTERY MAINTENANCE

A. PREPARING TO CHARGE A BATTERY

1. Be sure the area around the stacker and the battery is well ventilated while battery is being charged.

2. The battery terminals, connections and wiring connections should be clean and free of corrosion. When cleaning any of these components wear a face shield or other suitable protective eyewear.

3. For a sealed battery (a battery without cell caps) carefully follow the manufacturer's recharging instructions that are provided with the battery. If you do not have a copy of these instructions or the instructions for the battery charger they are available free of charge by calling Presto @ 1-800-343-9322.

4. Read, understand and follow all battery and battery charger manufacturer's specific precautions while working with and/or charging batteries.

B. LOCATING THE CHARGER

1. Locate charger as far away from battery as the cables permit.
2. Do not operate charger in a closed area or restrict ventilation in any way.

C. PRECAUTIONS FOR GROUNDING AND AC POWER CORD CONNECTION

Charger should be grounded to reduce risk of electric shock. Charger is equipped with an electric cord having an equipment-grounding conductor and grounding plug. The plug must be plugged into an outlet that is properly installed and grounded in accordance with all local codes and ordinances.

DANGER

Never alter the AC cord or plug provided. If it will not fit outlet, have proper outlet installed by a qualified electrician. Improper connection can result in a risk of an electric shock.

D. BATTERY CHARGER CONNECTION PRECAUTIONS

CAUTION

Connect and disconnect the DC output plug (or clips) only when the AC cord is disconnected from the electric outlet. Never allow clips to touch each other.

1. To charge the unit, plug the charger into the 110 volt wall outlet. The charger is pre-wired to the battery.

2. Disconnect the charger from the 110 volt wall outlet once the indicators read fully charged.

SECTION 6

MAINTENANCE

Generally, the DBP Series DC Electric Scissor Lifts require very little maintenance. Reasonable care will result in excellent trouble-free performance.



Never go under or service lift with a load on the table or with the scissor mechanism unblocked. Always service the lift in a down position.

A. ROUTINE MAINTENANCE:

All routine maintenance should be performed monthly and can be performed on the standard DBP Series DC Electric Scissor Lifts in a lowered height position. Before performing any maintenance, disconnect the battery. Then raise the top over its center position, secure in place and perform the routine listed (1 through 7).



Wood blocks should be cut to the proper length and be of a hard wood variety. Check for defects or damage to the blocks prior to each usage. These blocks are to be used only if the maintenance check has been damaged or misplaced.

- 1). Check oil level. Add oil if necessary.
- 2). Check rollers for signs of wear. Replace if damaged.
- 3). Check snap ring and shield. Replace if damaged.
- 4). Check hydraulic lines for damage or leaking. Replace if damaged.
- 5). Check for oil spots on the floor. Trace leaks to the proper fitting and tighten.
- 6). Check wiring for damage. Replace immediately if any sign of wear is evident.
- 7). Bearings on these lifts are permanently lubricated and require no servicing. Look for any signs of wear.

B. TROUBLESHOOTING MAINTENANCE:

LIFT WILL NOT MOVE

1. No operational noises:
 - a). Check power switch.
 - b). Check voltage at motor -- motor may have failed.
2. Operational noises:
 - a). Lift may be overloaded or jammed. Check load weight and obstructions.
 - b). Oil shortage -- reservoir low or oil line failure. Repair or replace.
3. Motor overheats:
 - a). Excessive cycle rate (15 per hour max.).
 - b). Low voltage -- check voltage at motor.
 - c). Oil starvation -- check filter in reservoir.

LIFT OPERATING SLOWLY

1. Up cycle:
 - a). Oil starvation -- check filter in reservoir.
 - b). Oil viscosity -- oil is too heavy or too thin.
 - c). Air in cylinder -- cycle lift with no load 2 times and hold down button for 20 seconds after bottoming out on each cycle.
2. Down cycle: (single acting cylinders)
 - a). Pinched hydraulic lines.
 - b). Oil viscosity is too heavy.
3. Lift raises, then slowly lowers without power:
 - a). Leaking hydraulic lines or fittings (check for telltale oil spots).
 - b). Check valve in pump -- may not be seating. Requires new pump.
4. Lift will not lower when energized:
 - a). Down solenoid faulty. Check voltage -- may be low or wrong voltage for coil. Check continuity of coil (burned out).
 - b). Pinched hydraulic lines.
 - c). Oil viscosity is too heavy.

SECTION 7

SERVICE

A. REPLACING CYLINDER SEALS:

1. Lower the lift to its lowest position. Then lift the top to its over center position and secure.
2. Disconnect the negative battery terminal.
3. Disconnect the hydraulic hose from the cylinder and cap the line to prevent hydraulic fluid loss.
4. Loosen the set screws holding the cylinder pin.
5. Remove the cylinder pin.
6. Lift the cylinder out of the lift.



Hold the cylinder securely while removing the pin to prevent it from falling to the floor.

7. Clamp cylinder securely at the base end.
8. Completely collapse cylinder piston.
9. Push gland into the cylinder 1/8"- 3/16".
10. Remove retaining ring.
11. Remove piston rod, piston and gland from cylinder.
12. Remove rod nut, piston and gland.
13. Remove and replace seals and wipers.
14. Assemble piston and gland to piston rod.
15. Assemble rod nut to piston rod and torque to 100 ft./lb.
16. Lubricate piston and seals and install cylinder.
17. Insert retainer ring.
18. Install cylinder and hydraulic lines.
19. Fill reservoir.
20. a). For the lifts serviced in lowered position, lower tabletop completely.
21. Cycle lift 2-3 times adding oil if necessary.
22. Recheck reservoir oil level.

SECTION 8

TROUBLESHOOTING

IF LIFT DOES NOT RISE TO FULL HEIGHT — check for leaks or shortage of oil. Maintain the proper oil level. To check oil level, follow these instructions:

- ↑ On left hand side, on top of oil well, you will find a hexagon cap screw which is also a dipstick.
- ↑ Remove the cap screw and fill oil well with hydraulic oil. Oil should reach notch on dipstick.

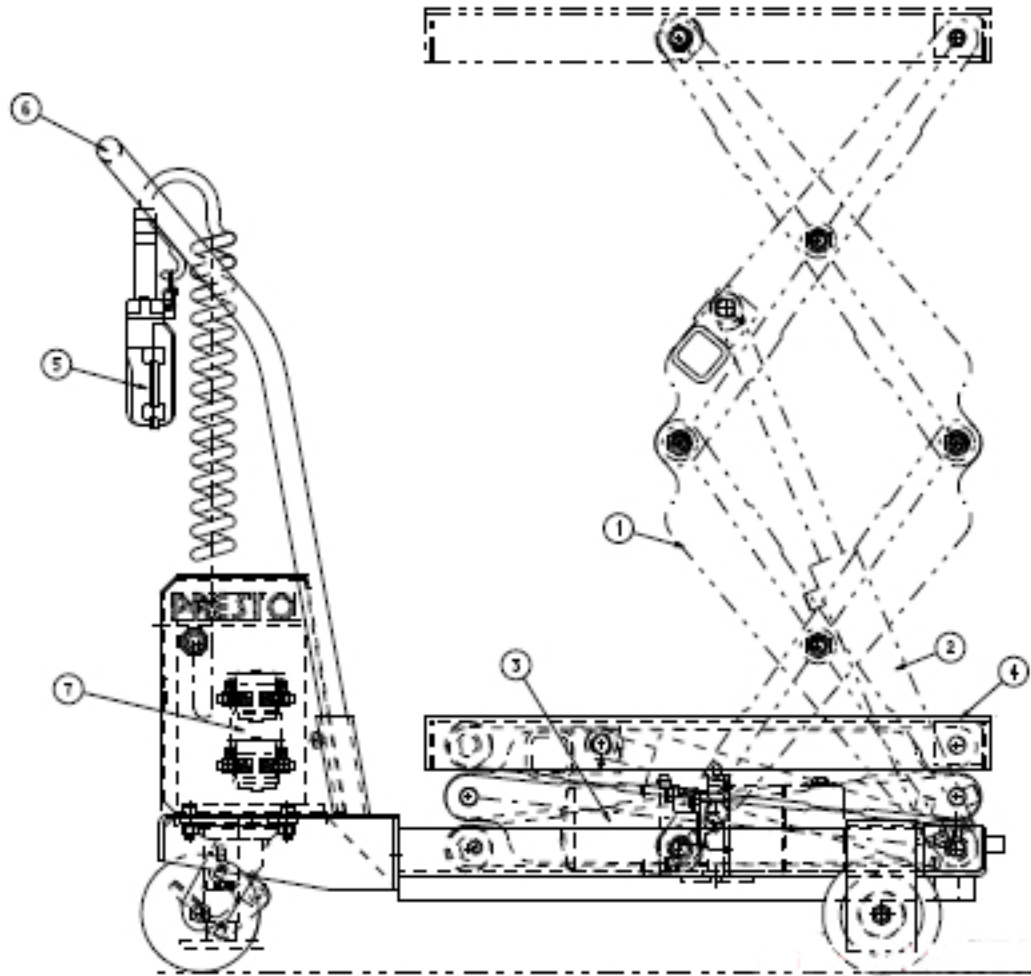
IF THE LIFT TENDS TO CREEP DOWNWARD UNDER A LOAD — a speck of dirt may be obstructing the seating of the valve and allowing leakage. To correct, follow these instructions:

- ↑ Raise lift to full lifting height and then lower it to lowest point of lift. It may be necessary to do this five or six times. In lowering the lift, lower it in stages, that is, lower the lift six inches to a foot at a time. This will dislodge the dirt and lift will operate properly.

TROUBLESHOOTING MAINTENANCE -- ELECTRIC

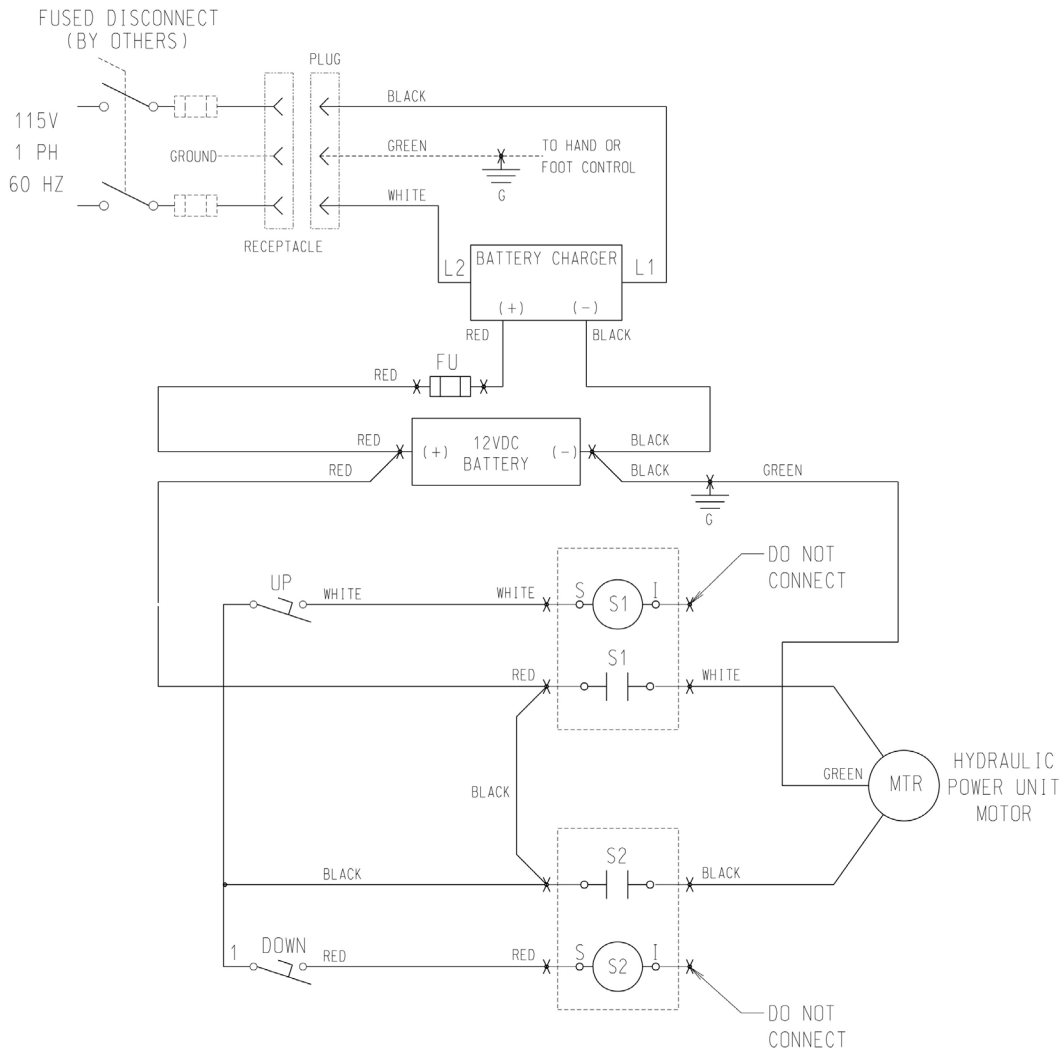
Problem	Probable Cause	Service Required
Lift will not move w/ no motor noise	Loss of power Motor failure	Check power switch or battery and charger Check voltage at motor
Lift will not move with motor noise	Overloaded lift Motor	Check load Low voltage at motor -- battery low Oil starvation Check oil reservoir
Motor overheats	Excessive cycling rate	Check cycle rate, 15 cycles per hour maximum Low voltage. Check voltage at motor
Up cycle slow	Oil starvation Oil viscosity Air in cylinder system	Check and fill reservoir Check oil viscosity and replace if necessary Purge system by cycling several times to full extension and retraction
Down cycle slow	Blockage in hydraulic line Oil	Check for pinched lines Oil viscosity too heavy; replace Oil contaminated; replace
Lift raises then lowers slowly	Check valve Not seating Leaking fitting	Remove and clean Check fittings and lines for telltale oil spots

DBP SERIES PRODUCT ILLUSTRATIONS

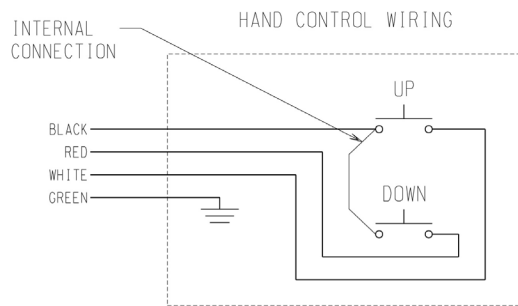


**FIGURE 1:
DBP SCISSOR LIFTS**

**FIGURE 2:
ELECTRICAL SCHEMATIC 12 VOLT DC POWER -- DBP**



X - INDICATES WIRE CONNECTION IN THE HOUSING



HAND CONTROL & FOOT CONTROL
USE SAME COLOR CODE.

FIGURE 3: HYDRAULIC SCHEMATIC -- DBP SERIES

BI-DIRECTIONAL PUMPS

These pumps are driven by reversible motors and are primarily used to power double-acting cylinders in both directions. Locking checks that hold the load in either direction are standard.

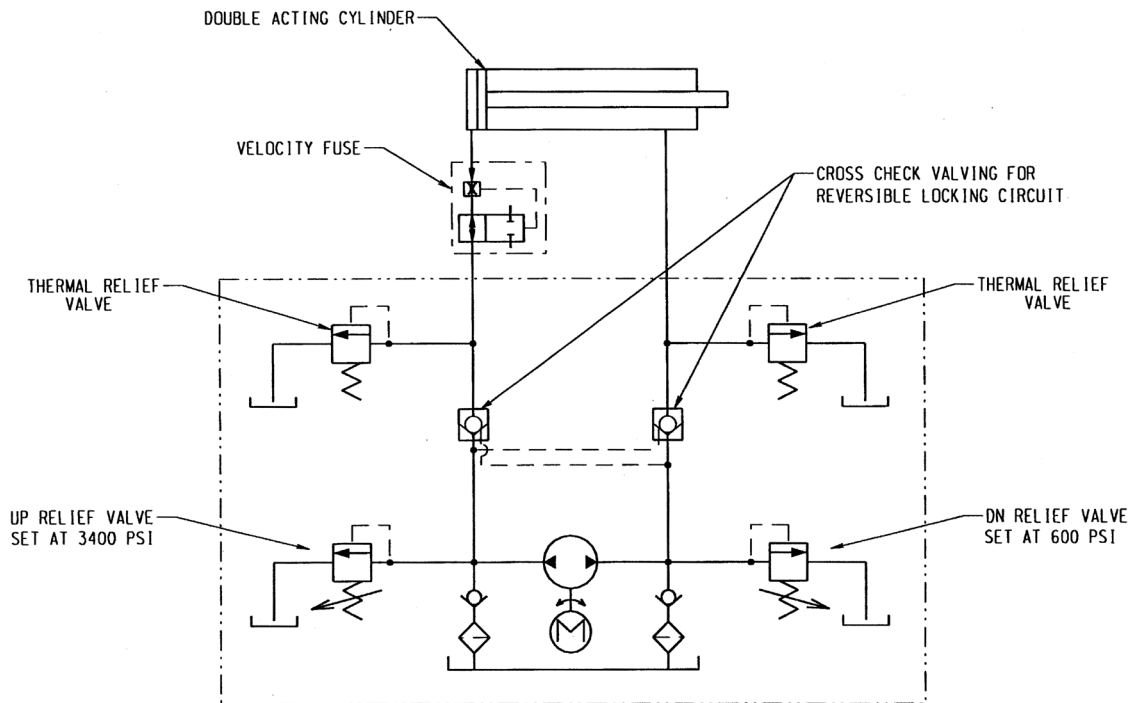


Table 1 – Hydraulic Oil Specifications

If the lift will be used at normal ambient temperatures, Presto Lifts supplies the unit with Conoco Super Hydraulic 32 oil. This may be replaced by any other good quality oil with 150 SSU at 100° F and rust and oxidation inhibitors and anti-wear properties.

If the lift will be used at ambient temperatures below 0°F, use aircraft grade hydraulic oil. Type 15 aircraft hydraulic oil is recommended.

The following are equivalent to CONOCO SUPER HYDRAULICS 32:

TYPE	MANUFACTURER
AW32	CITGO
DTE 24	EXXON/MOBIL
NUTO H32	EXXON/MOBIL
AMOCO AW32	CHEVRON (AMOCO CO.)



It is very important to keep the hydraulic oil free of dirt, dust, metal chips, water, and other contamination. Most of the problems with hydraulic systems are caused by contamination in the oil.

FIGURE 4: HYDRAULIC ARRANGEMENT for DBP SERIES

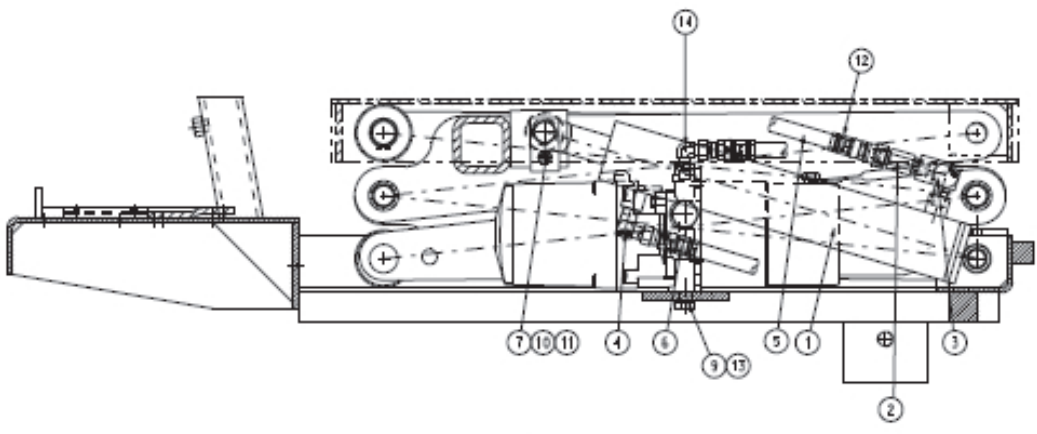
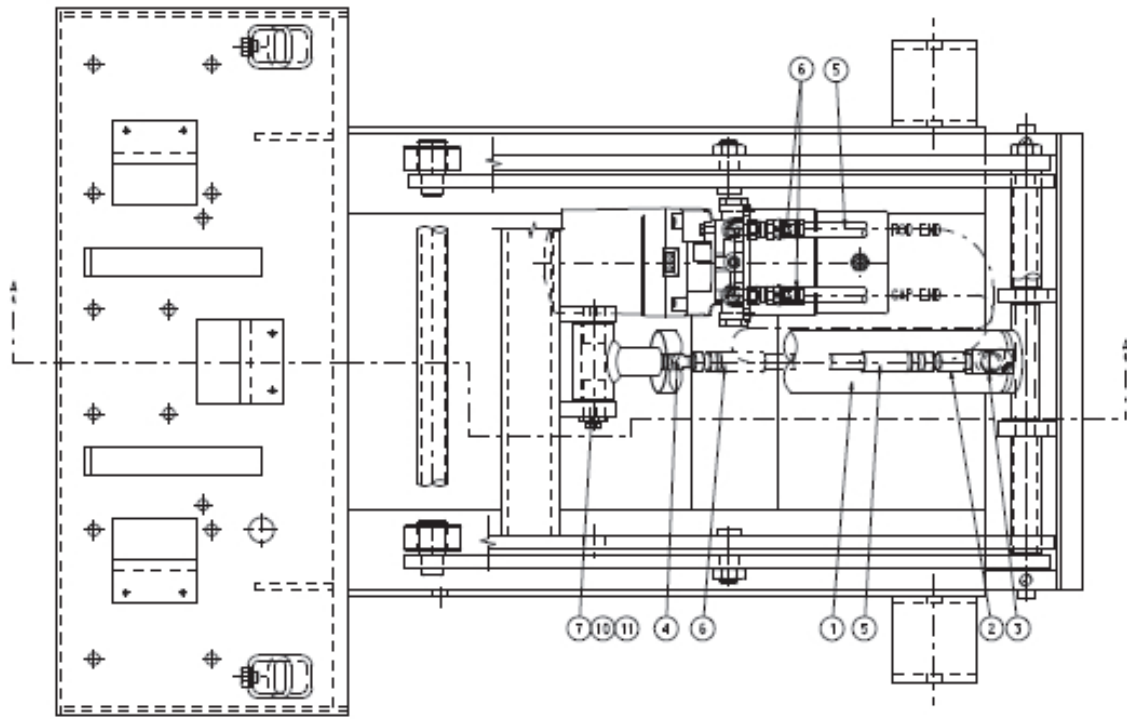


FIGURE 5: ELECTRICAL ARRANGEMENT for DBP Series

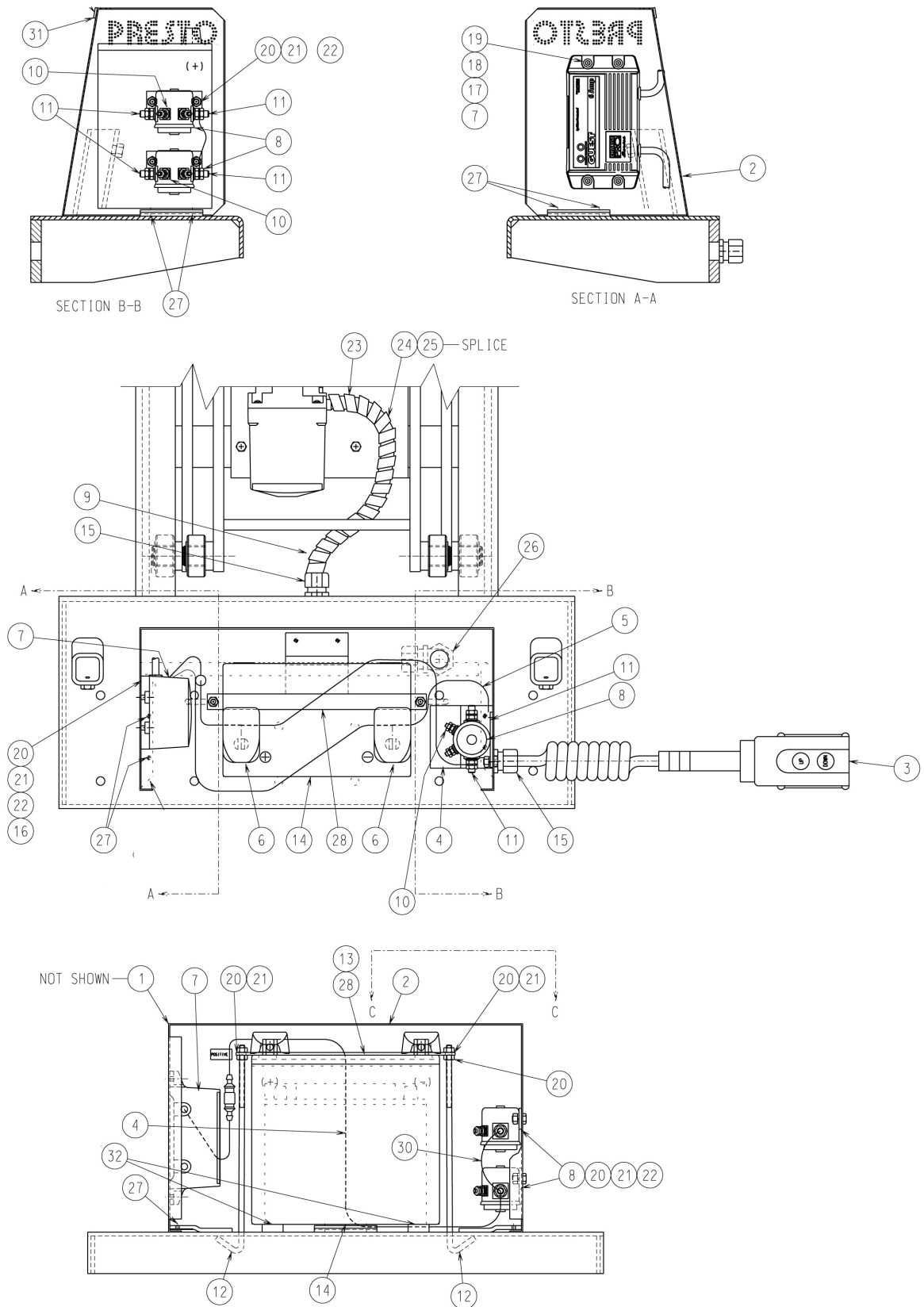
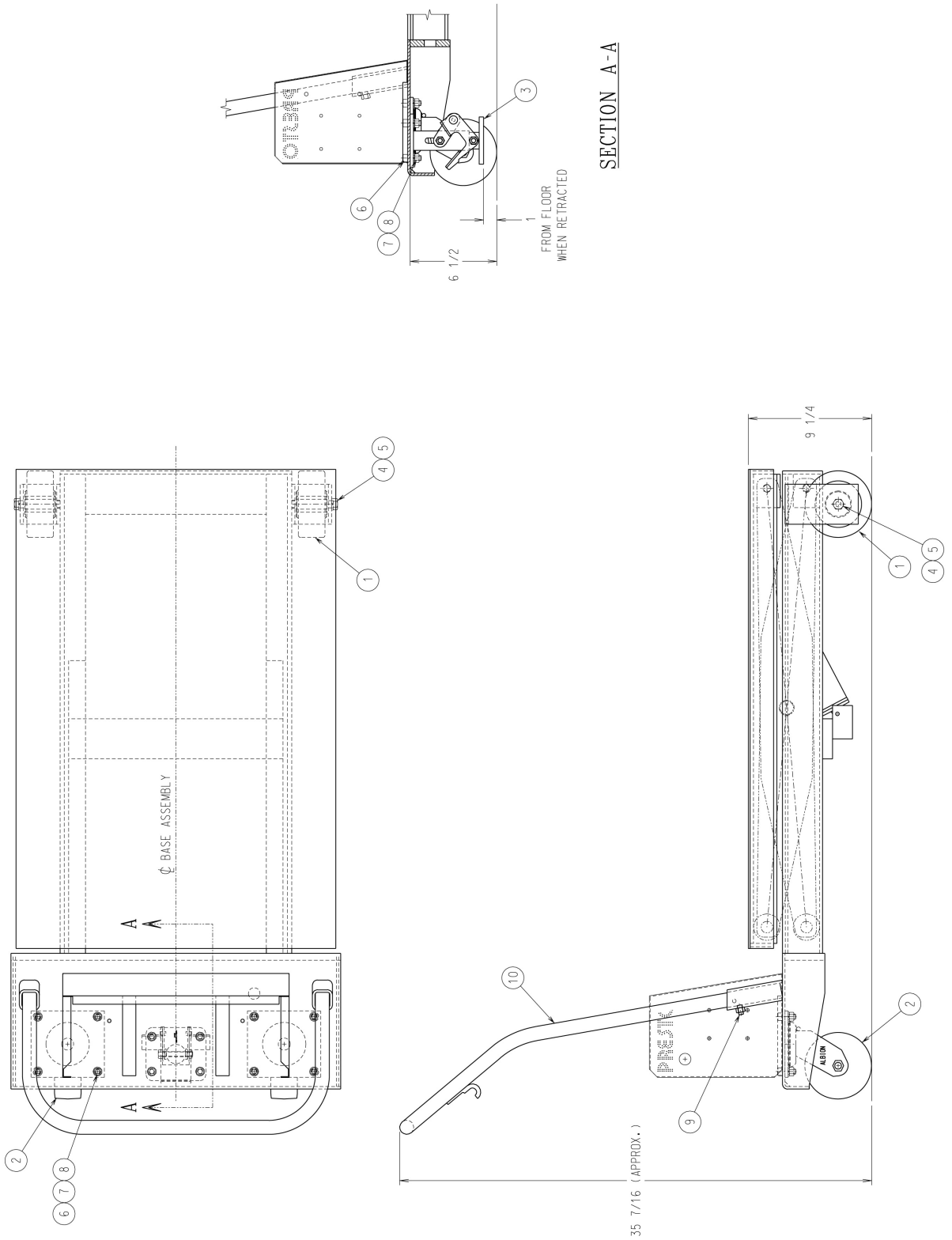


FIGURE 6: ACP PORTABLE KIT CASTER for DBP Series



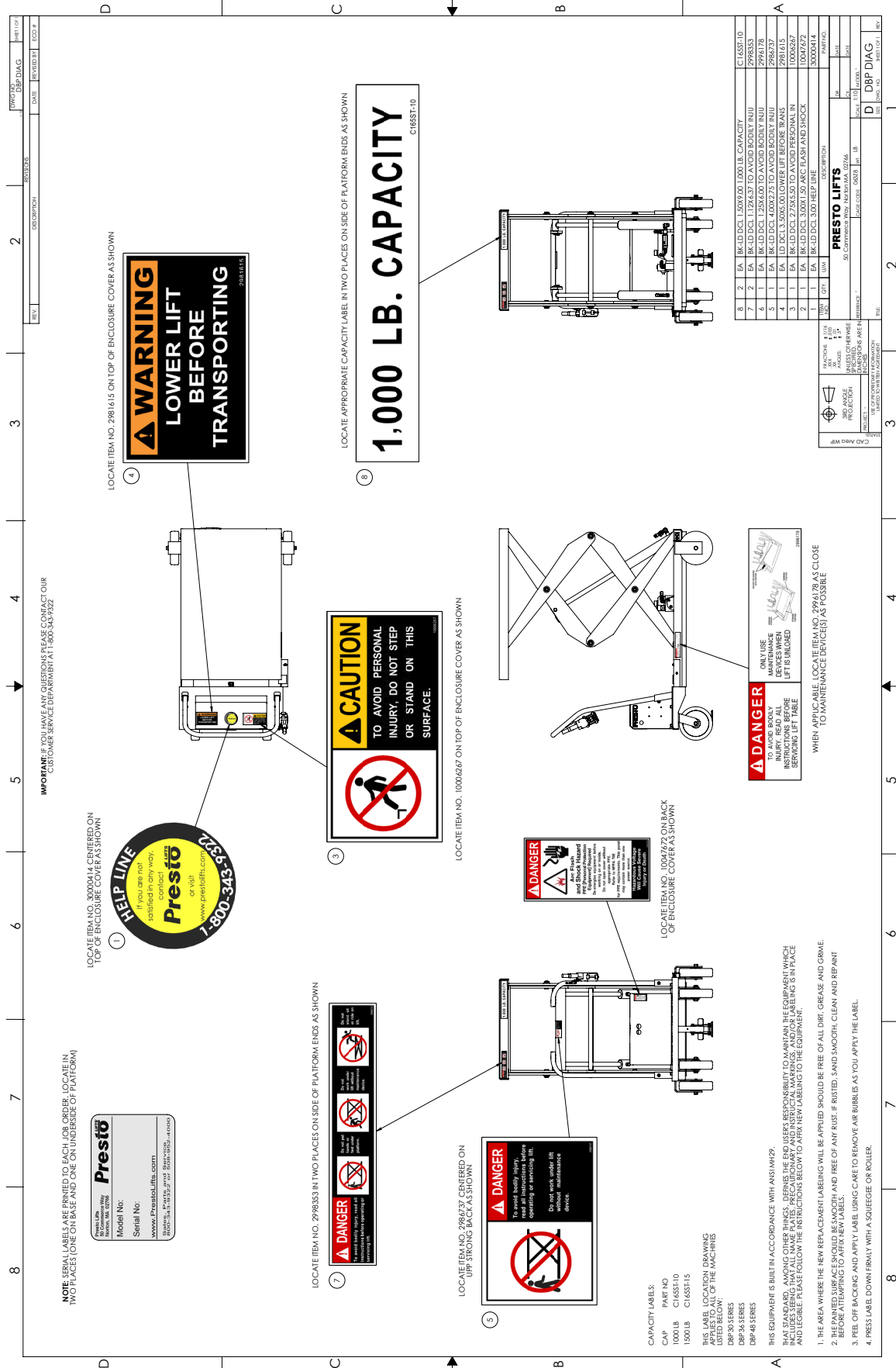


Figure 7: Labels and Locations

PARTS

Standard parts may be returned with a 20% restocking fee. Modified or custom-engineered parts are not returnable. Unfortunately, due to potentially concealed damage, all sales of electrical assemblies are final.

QUALITY ISSUES

Should you feel there is a quality problem, please contact the seller to ask questions and gather information on how to rectify the issue. Presto Lift Inc. reserves the right to determine potential credits, as a result of factory defects, based on its inspection of the merchandise.

GENERAL

All products shipped from our factory have passed Quality Assurance inspection and testing. The carrier of choice has signed for, and accepted the product in new working condition. The customer should inspect to ensure it is not received damaged, has no concealed damage or is not incomplete. Parts orders are determined to be complete based upon Presto Lift, Inc. inspection sheets and carrier shipping weights.

Ordering Replacement Parts

Presto Lifts has carefully chosen the components in your unit to be the best available for the purpose. Replacement parts should be identical to the original equipment. Presto Lifts will not be responsible for equipment failures resulting from the use of incorrect replacement parts or from unauthorized modifications to the unit.

Presto Lifts can supply all replacement parts for your lift. With your order, please include the model number and the serial number of the unit. You can find these numbers on the name plate. This plate is located within the scissors mechanism.

To order replacement parts, please call the Presto Parts Department. Parts are shipped subject to the following terms:

- FOB factory
- Returns only with the approval of our parts department.
- Credit cards preferred (except parts covered by warranty).
- Freight collect for truck (except parts covered by warranty).
- Freight – prepaid and invoice for small parcel shipments (except parts covered by warranty).
- The warranty for repair parts is 30 days from date of shipment.

Parts replaced under warranty are on a “charge-credit” basis. We will invoice you when we ship the replacement part, then credit you when you return the worn or damaged part, and we verify that it is covered by our warranty. Labor is not covered under warranty for Parts orders.

Presto Parts Department

50 Commerce Way
Norton, MA 02766

Telephone: 800-343-9322

FAX: 888-788-6496

Email: service@PrestoLifts.com

www.PrestoLifts.com

RETURN GOODS AUTHORIZATION POLICY

Presto Lifts provides the Return Goods Authorization (RGA) Policy, for specific models, as a courtesy to our distributors in the event they do not receive what they ordered. If a customer wishes to return a Presto Lifts product, please contact the Customer Service Department and request an RGA number. This request must be made on or before the fifteenth calendar day following the date of Presto Lifts' invoice for the merchandise. Not all units are returnable. Quantity orders and special designs cannot be returned under any circumstances. Presto Customer Service reserves the right for final judgment on all product returns.

The RGA number must appear on the outside of any packaging material for a return to be accepted and processed by Presto Lifts. Customers shipping returns from the Continental US, Canada, or Mexico have thirty (30) days from date of RGA issue to have the product arrive at Presto Lifts' facility. All merchandise must arrive Free on Board at Presto Lifts' facility or the shipment will be refused and returned to the sender. All credits are issued less restocking and refurbishing charges, regardless if the merchandise was damaged in transit.

Return addresses: please refer to your RMA for the address to which your product should be returned.

Presto Lift Inc.
715 Highway 77
Manila, Arkansas 72442

Telephone: 800-343-9322
Fax: 888-788-6496

Presto Lifts Limited Warranty Policy

Presto Lifts warrants all of its products against defects in the welded structural frame and, if applicable, scissor legs from faulty material and workmanship for a period of five (5) years from the date of invoice.

All batteries and battery chargers have a limited warranty against defects in faulty material and workmanship for a ninety (90) day period from the date of invoice through Presto Lifts. All other components have a limited warranty against defects in faulty material and workmanship for a two (2) year period from the date of invoice and a 30 day limited warranty on labor. Please note that prior authorization from Presto Lifts is required on all warranty work.

There are no implied warranties of any kind, more specifically, there are no warranties of merchantability or fitness for any particular purpose. Presto Lifts' sole warranty shall be as set forth in this limited warranty.

Presto Lifts will elect to repair or replace a defective component without charge, if any components should become defective within the limited warranty period. Proof of purchase is required for warranty. The charge for shipping the defective component is the responsibility of the buyer and must be accompanied with an RMA number. The shipping charge to return the component to the buyer is the responsibility of Presto Lifts, Inc.

This limited warranty does not cover labor expense for removal or reinstallation of components after thirty days. This limited warranty shall not cover, among other things: damages resulting from foreign matter or water, failure to provide reasonable and necessary maintenance, and if applicable, use of product while charger is plugged into an AC outlet, or failure to follow operating instructions. The limited warranty is not valid for damage resulting from negligence, accident, unreasonable use, abuse or misuse, exceeding data plate capacities or altering the product without Presto Lifts authorization.

Presto Lifts expressly disclaims and excludes any liability for consequential, incidental, indirect or punitive damages or financial loss to people or property resulting from any breach of warranty or the operation or failure of this product.

Presto Lifts makes no representation that this product complies with local, state, or federal safety/product standards codes. Should this product fail to comply in any way with those codes, it shall not be considered a defect of materials or workmanship. Presto Lifts shall not be held liable for any damages resulting from noncompliance. It is the dealer's responsibility to exercise this limited warranty. This limited warranty is provided to the original purchaser (defined as the original end user) and is nontransferable. This constitutes the complete and final agreement involving Presto Lifts and limited warranty obligations for products.

MANY NEEDS REQUIRE MANY OPTIONS...

Presto ^{LIFTS}



LET PRESTO MEET THOSE NEEDS!

Call Presto Sales
for stock or
customized lift inquiries:
800-343-9322

Email: sales@prestolifts.com

