

Presto Lifts Inc.  
2 Hampshire Street, Suite 102  
Foxborough, MA 02035  
Phone: 800-343-9322 • Fax: 888-788-6496  
service@prestolifts.com  
www.PrestoLifts.com

# Owner's Manual

## Keg Lifter

### Model: FKL

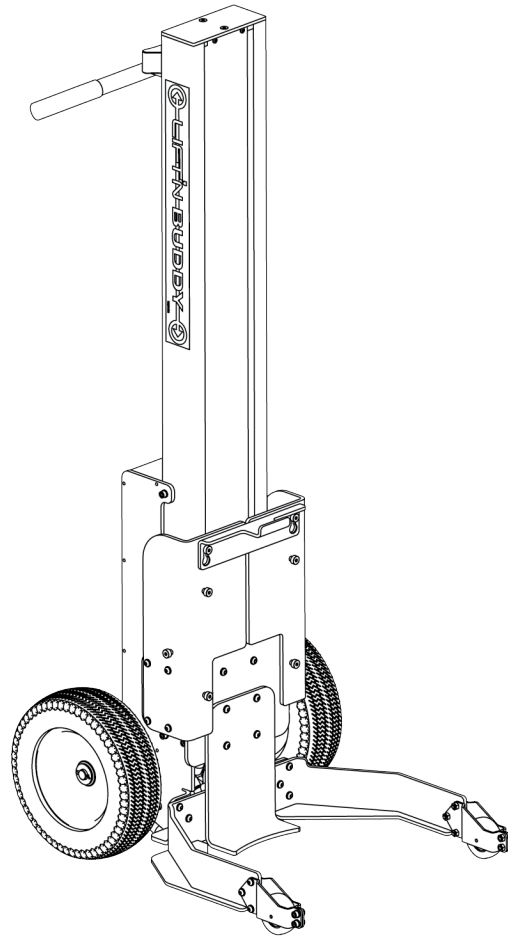

---

## CONTENTS

1. FOR YOUR SAFETY	2
1.1 SAFETY ALERT SYM. & SIGNAL WORDS	
1.2 SAFETY ALERT SYMBOLS	
1.3 SIGNAL WORDS	
2. RESPONSIBILITY OF OWNERS & USERS	2
2.1 INSPECTION AND MAINTENANCE	
2.2 REMOVAL FROM SERVICE	
2.3 REPAIRS	
2.4 OPERATORS	
2.5 BEFORE OPERATION	
2.6 DURING OPERATION	
2.7 MODIFICATIONS OR ALTERATIONS	
3. IMPORTANT OPERATIONAL INFO.	3
4. SPECIFICATIONS	3
5. OPERATION	4
5.1 FEATURE IDENTIFICATION	
5.2 ASSEMBLY	
5.3 ON/OFF CONTROL & CHARGING	
5.4 LIFT OPERATION	
5.5 HANDLE ADJUSTMENT	
6. OPERATION TROUBLESHOOTING	5
7. WIRING DIAGRAM	5
8. MAINTENANCE: ADJUST & REPLACE	6
8.1 DRIVE BELT TENSIONING	
8.2 BATTERY INSTALLATION	
9. WARRANTY	7

# WELCOME

Congratulations on your selection of a Presto Lifts Keg Lifter. We are certain that you will be pleased with your purchase of this unique and innovative device. This manual contains information on how to operate and use your new device. For technical questions or to order parts please call toll free at 800-343-9322.

## 1. FOR YOUR SAFETY

### 1.1 SAFETY ALERT SYMBOLS AND SIGNAL WORDS

The safety of all persons operating, maintaining, repairing, or in the vicinity of this equipment is of paramount concern. This is a powerful machine with moving parts, and is capable of causing personal injury if proper precautions are not taken. Therefore, throughout this manual, certain hazards have been identified which may occur in the use of the machine, and there are appropriate instructions or precautions which should be taken to avoid these hazards. In some cases, there are consequences which may occur if instructions or precautions are not followed. Below are the symbols and signal words along with their definitions referenced from ANSI Z535.4 - Product Safety Signs and Labels.

### 1.2 SAFETY ALERT SYMBOLS

These are the safety alert symbols. They are used to alert you to potential physical injury hazards. Obey all safety messages that follow this symbol to avoid possible injury or death.



For use with DANGER signal word.  
(Red Background)



For use with WARNING signal word.  
(Orange Background)



For use with CAUTION signal word.  
(Yellow Background)

### 1.3 SIGNAL WORDS

The meaning of different signal words as defined by ANSI Standard Z535.4 indicates the relative seriousness of the hazardous situation.



#### DANGER

Indicates a hazardous situation which, if not avoided, will result in death or serious injury.



#### WARNING

Indicates a hazardous situation which, if not avoided, could result in death or serious injury.



#### CAUTION

Indicates a hazardous situation which, if not avoided, could result in minor or moderate injury.



#### NOTICE

Is used to address practices not related to personal injury.



#### SAFETY INSTRUCTIONS

(or equivalent) signs indicate safety- related instructions or procedures

## 2. RESPONSIBILITY OF OWNERS AND USERS

### 2.1 INSPECTION AND MAINTENANCE

The device shall be inspected and maintained in proper working order in accordance with the owner's manual.

### 2.2 REMOVAL FROM SERVICE

Any device not in safe operating condition such as, but not limited to, excessive leakage, missing rollers, pins, or fasteners, any bent or cracked structural members, cut or frayed electric, hydraulic, or pneumatic lines, damaged or malfunctioning controls or safety devices, shall be removed from service until it is repaired to the original manufacturer's standards.

### 2.3 REPAIRS

All repairs shall be made by qualified personnel in conformance with the instructions.

### 2.4 OPERATORS

Only trained and authorized personnel shall be permitted to operate the lift.

### 2.5 BEFORE OPERATION

Before using the device, the operator shall:

- Read and/or had been instructed about, and understood, the manufacturer's operating instructions and safety rules.
- Inspect the device for proper operation and condition. Any suspect item shall be carefully examined and a determination

made by a qualified person as to whether it constitutes a hazard. All items not in conformance with Retail Handling Solutions specifications shall be corrected before further use of the equipment.

## 2.6 DURING OPERATION

The device shall only be used in accordance with this owner's manual.

- Do not overload.
- Ensure that all safety devices are operational and in place.

## 2.7 MODIFICATIONS OR ALTERATIONS

Modifications or alterations to any Retail Handling Solutions industrial positioning equipment shall be made only with written permission from Retail Handling Solutions.

## 3. IMPORTANT OPERATIONAL INFORMATION

### 3.1 READ AND UNDERSTAND ALL INSTRUCTIONS BEFORE USING THIS PRODUCT

- Do not exceed the manufacturer's load rated capacity. Read capacity sticker or load capacity rating specification section of this operational manual.
- Never allow untrained operators to use this equipment.
- Do not raise or lower a load while transporting it. Wait until the device is stopped and at the load transfer location.
- Transport the load with its center of weight at its lowest point to improve stability.
- Make sure the lifting platform is completely under the load. Always load towards the rear.
- Avoid operating with obstructed views.
- Avoid operating on inclined surfaces. The device's weight needs to be supported by the operator at all times. Inclined surfaces will increase the weight that the operator needs to support.
- Never place an item on the lift that can roll off or tip over the unit.
- Floors that are damaged, cracked or uneven can catch wheels or casters and create a tripping hazard.
- Dirty, wet or slippery floors will reduce the traction of the operator and create a slipping hazard.
- Operators should wear protective footwear while using this device.
- The operator should receive training on how to maneuver and handle heavy loads.

## 4. SPECIFICATIONS

Weight: 77 lbs. / 35 kg

IP Class: IP41

Battery: 2 x 12VDC, 7.2 Ah, non-spillable

Charger: Input 120VAC; Output 24VDC, 2A

Max. Load: 175LBS. / 80KG

Load Type: One Keg (Type 1/2 & 1/4 Barrel, 50L)

Max Lift Shuttle Travel: 37.4"

Lift Capability: 35" under keg clearance

Cycle Time, lift up: 10 Sec (no load)

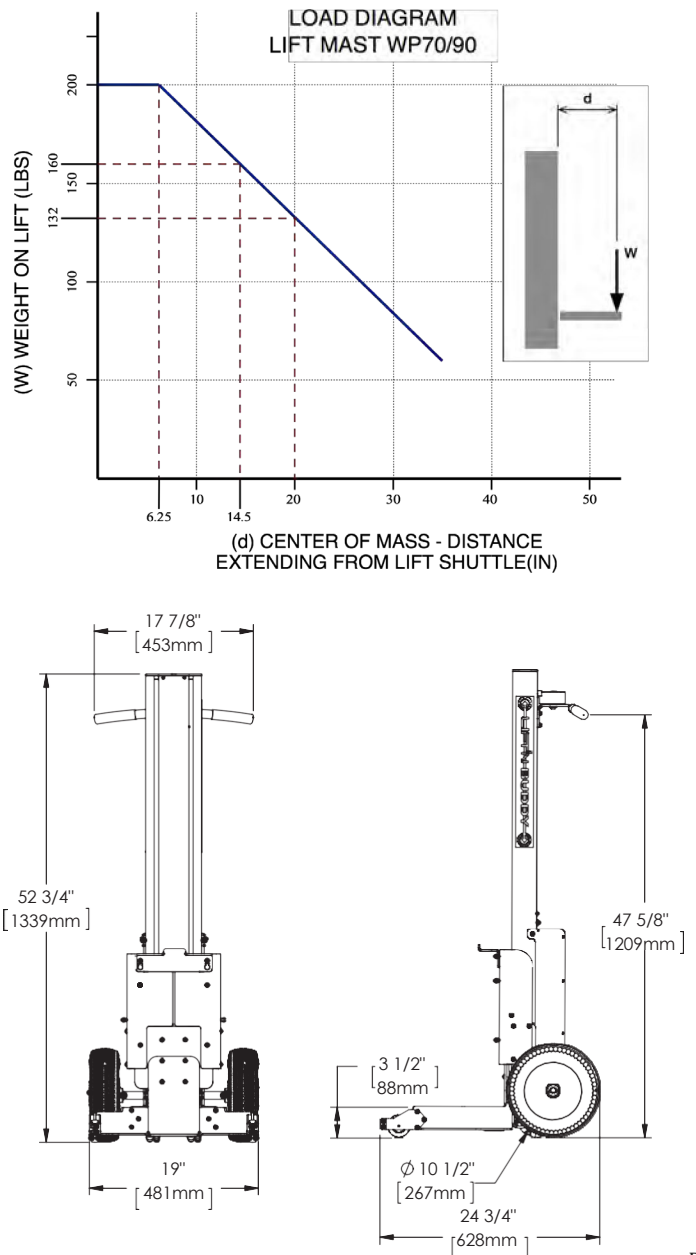

## 5. OPERATION

### 5.1 FEATURE IDENTIFICATION

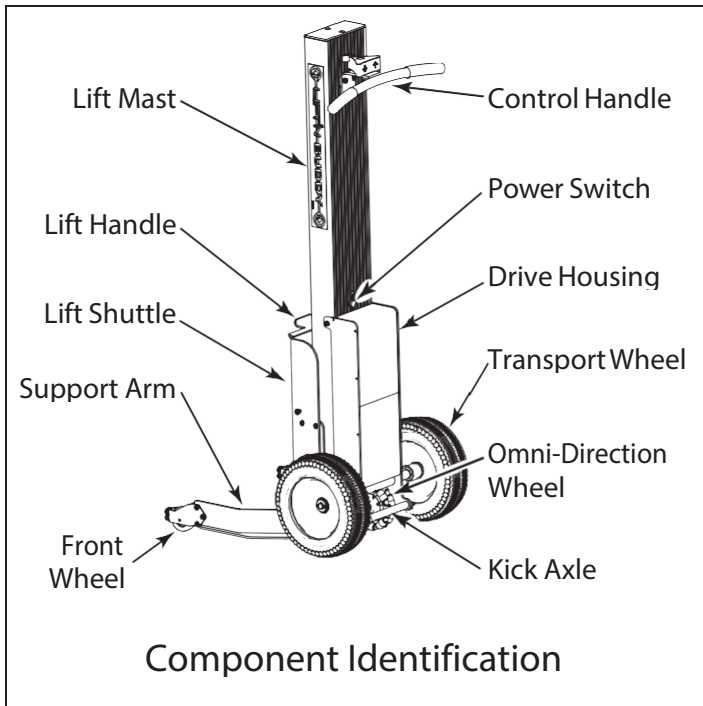

### 5.2 ASSEMBLY

The lift arrives mostly assembled. The shipping bracket needs to be removed from the control handle mounting location. The control handles needs to be installed.

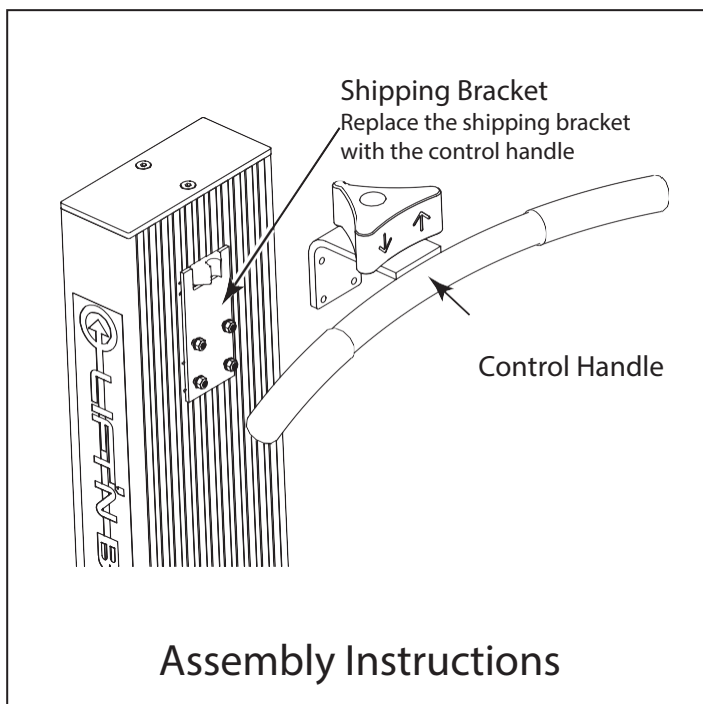

### 5.3 ON/OFF CONTROL AND CHARGING

Depress the power switch to turn the lift on.

The power switch must be in the “on” position for the batteries to charge.

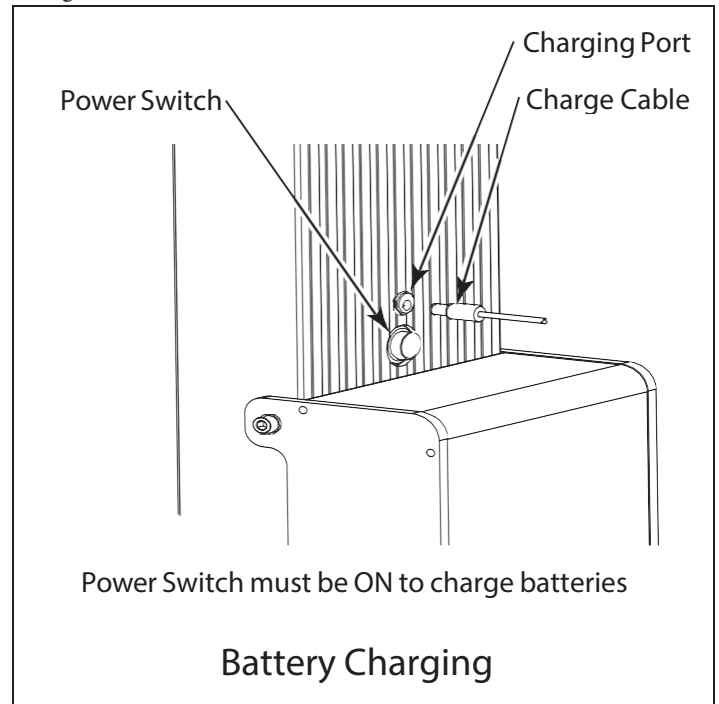

Note: Frequent charging will extend the life of the batteries.

Charger status light:

Amber - Charging

Green - Charge complete or not connected to the battery

### 5.4 LIFT OPERATION

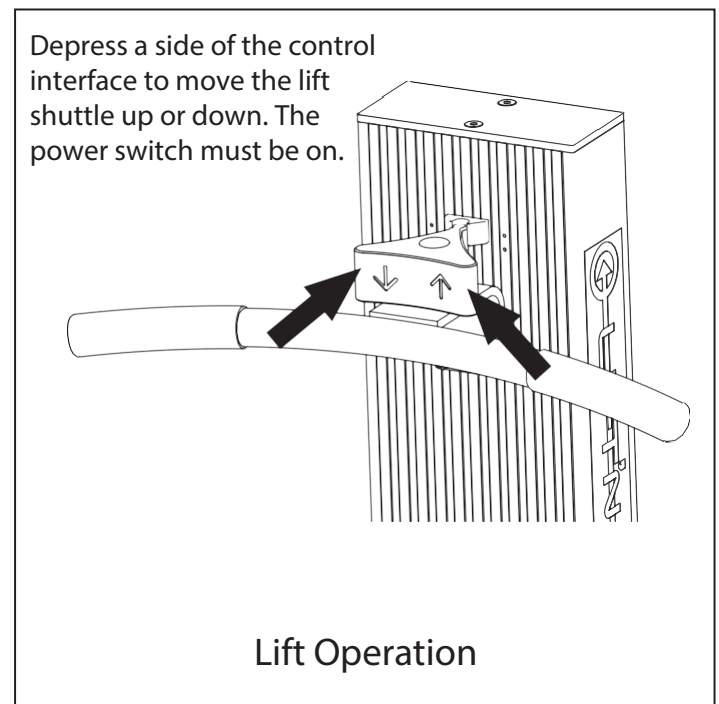

## 5.5 LIFT HANDLE ADJUSTMENT

The Keg Lifter Lift Handle has three mount positions for handling a variety of keg types and sizes. Place the Lift Handle in the appropriate position for the keg being handled.

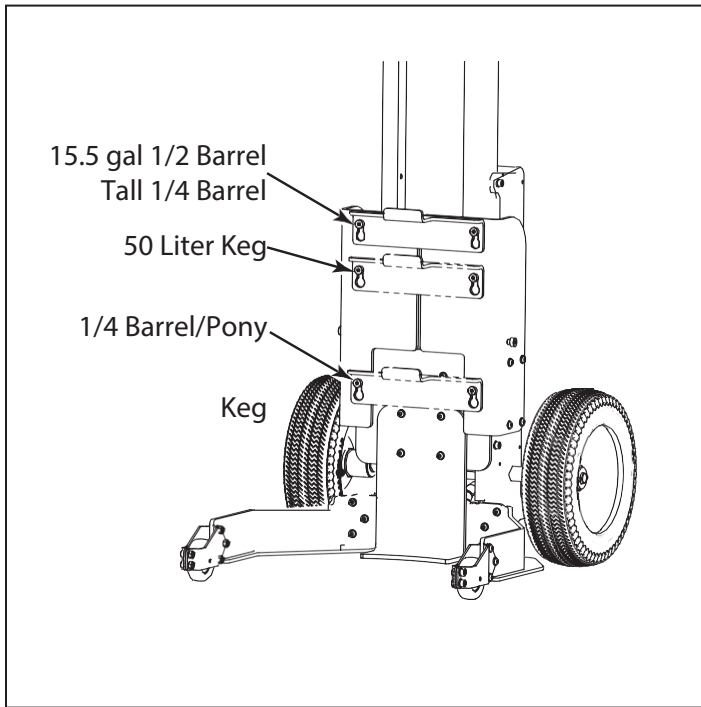

## 7. WIRING DIAGRAM

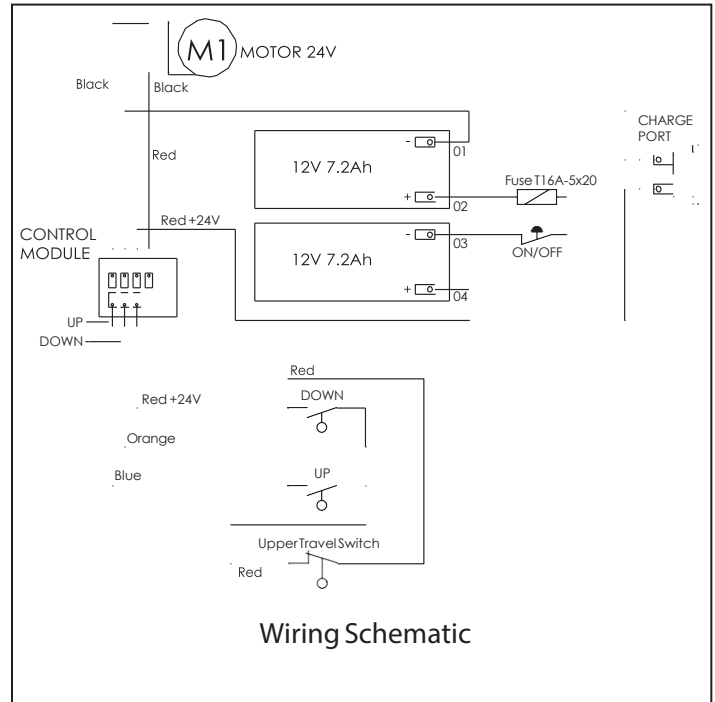

## 6. OPERATION TROUBLESHOOTING

Problem	Solution	Corrective Action
The Lift does not operate in the up or down direction	On - Off Switch is in the Off Position	Push the On-Off Switch to the on position
	The batteries are discharged	Plug the charger into the lift's charge port to charge the batteries. Avoid operating the lift to a completely discharged state on the batteries. The battery life will be extended if frequent charging is done before complete battery discharge.
	The main fuse located in the battery/drive enclosure has faulted	Replace the main fuse
	A battery connection lead is disconnected.	Inspect and verify the battery connection leads
The lift moves down but not up	The batteries are discharged and will no longer accept a charge.	Replace both of the batteries with new batteries. Charge the batteries before using the lifter. Avoid operating the lift to a completely discharged state on the batteries. The battery life will be extended if frequent charging is done before complete battery discharge.
	The upper travel limit switch is activated	Look for a faulty or damaged upper travel limit switch or switch condition
The lift moves up but not down	The lift is overloaded and the control current limiter is activating.	Reduce or remove the load on the lift.
	The down direction drive clutch is activating.	The lift carriage needs a small weight to initiate movement. The lift should be in the vertical position and it must not have any obstructions in its downward travel.
The charger is plugged in but the charger indicator light remains green.	The Lift ON/OFF switch is in the Off Position	Turn the ON/Off switch ON
	The main fuse located in the battery/drive enclosure has faulted	Replace main fuse
	A battery connection lead is disconnected.	Inspect and verify the battery connection leads
The lift slowly creeps down when it is elevated with a weight on it.	The drive gears can be back driven under a loaded condition.	This is a normal condition under certain load and operational conditions.
The timing belt makes crack or squeaking sound near the upper sprocket.	The timing belt is slack or is running skewed.	Tension or adjust the drive belt with the two screws at the top of the mast. The drive belt cover may need to be removed to inspect the adjustment process.

## 8. MAINTENANCE: ADJUST & REPLACE

### 8.1 DRIVE BELT TENSIONING

The drive belt is a steel reinforced timing belt. It is typically maintenance free. Occasional belt tensioning could be required to correct any alignment or skipping problems that could arise.

- Remove the drive belt cover for visual access and inspection.
- Inspect the belt for damage, dirt, misalignment and a slack condition.
- Use a M4 hex tool to make adjustments to the tensioning screws.
- After adjustment, the drive belt should track between the flanges of the drive pulley.
- After tensioning or adjustment there must be clearance between the upper pulley and the drive unit cap.
- Verify operation of the belt by an operational test.
- Install the drive belt cover.

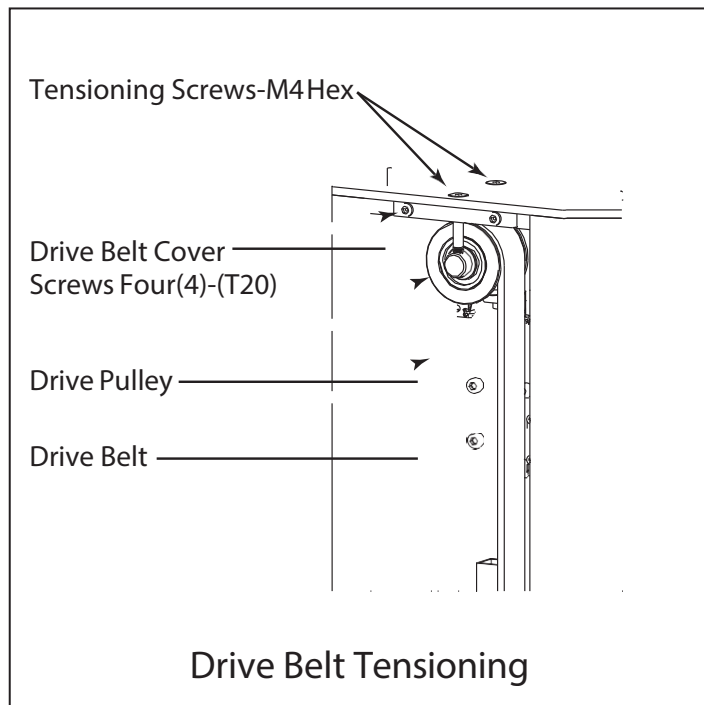

**Drive belt performance troubleshooting**

- Snapping sounds from the upper drive pulley could indicate a belt tracking problem. The belt is riding up the flange of the upper pulley and snapping back in place.
- Cracking or snapping noises from the lower drive pulley is most likely a tensioning or loose belt condition. Under load this condition could be worse and the unit may not lift a load.

### 8.2 BATTERY INSTALLATION

The batteries included with this device are sealed and non-spillable. The battery life will be prolonged with frequent charges. The batteries are a consumable and replaceable item and will eventually need to be replaced.

Remove the upper drive house cover to gain access to the battery compartment.

- Remove the old batteries
- Inspect battery wires and connections for wear or abrasion.
- Dispose or recycle the lead batteries following appropriate local disposal procedures.

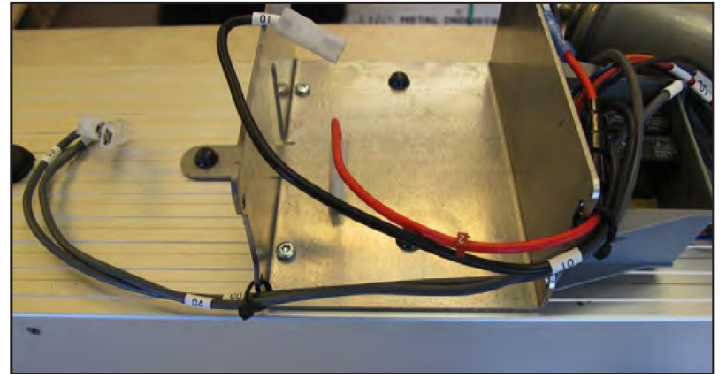

Install new batteries into the upper and lower battery compartments.

- Replace both batteries at the same time.
- Position the batteries with the terminal tabs orientated toward the battery wire passage notch on the mount plate.
- Connect wire labeled 1 to the (-) terminal and wire 2 to the (+) red terminal of the lower battery.
- Connect wire labeled 3 to the (-) terminal and wire 4 to the (+) red terminal of the upper battery.

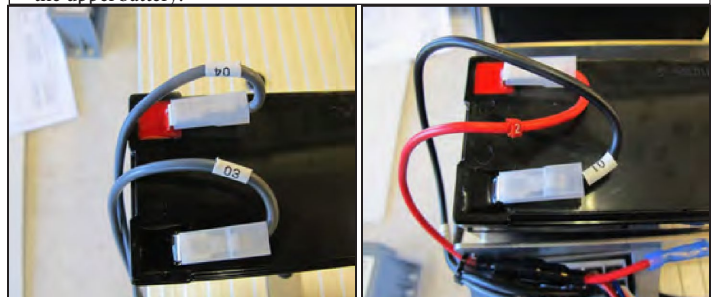

The newly installed batteries should be positioned as shown.

- Replace the battery compartment cover.



## 9. PRESTO LIFTS' LIMITED WARRANTY POLICY

Presto Lifts warrants this product to be free from defects in material or workmanship for the duration of the warranty period. Warranty periods vary and begin on the date of shipment. For specific warranty information, contact Presto Lifts with the machine's serial number. Any claim for breach of this warranty must be received in writing by Presto Lifts within the warranty period. Warranties shall not cover failure or defective operation, caused by misuse, misapplication, negligence or accident, exceeding recommended capacities, or any alteration or repair of the item purchased which has not been authorized by Presto Lifts. Except as set forth herein, Presto Lifts makes no other warranties, express or implied, including THE WARRANTIES OF MERCHANTABILITY AND OF FITNESS FOR A PARTICULAR PURPOSE, all of which ARE HEREBY EXCLUDED.

Presto Lifts meets the labeling requirements of California's Proposition 65. Presto Lifts makes no warranty or representation with respect to the compliance of any product with other State or local safety or product standard codes and any failure to comply with such codes shall not be considered a defect of material or workmanship under this warranty. Presto Lifts shall not be liable for any direct or consequential damages arising out of such non-compliance.

Presto Lifts' obligations under any warranty or for any other damages which may arise under any sale, agreement, or contract, are limited to the replacement or repair of defective components at its factory or another location at Presto Lifts' discretion. This is buyer's sole remedy under any such warranty, sale, agreement, or contract. Presto Lifts will not be liable for consequential, incidental, exemplary, or punitive damages of any kind resulting from a breach of any warranty that it has provided or for breach of any term of any sale, agreement, or contract. Any warranty may be altered only in writing by Presto Lifts.

All commodities, software, or technology purchased from Presto Lifts are subject to the export and re-export control laws and regulations of the United States, including but not limited to the Export Administration Regulations ("EAR") and Department of the Treasury Office of Foreign Asset Controls ("OFAC") Regulations. Presto Lifts expects all distributors and customers to comply with these laws and regulations. Without limiting the foregoing, the distributor/customer cannot, without proper authorization from the applicable United States Government Agency, export, re-export, or transfer any commodity, software, or technology purchased from Presto Lifts, either directly or indirectly, to any entity, country, or national of any country in breach of such laws and regulations. Furthermore, Presto Lifts expects that the distributor/customer shall indemnify and hold harmless Presto Lifts from and against any claim, proceeding, action, fine, loss, cost and damages arising out of or relating to any noncompliance with export control regulations by distributor/customer, and distributor/customer are expected to compensate Presto Lifts for all losses and expenses resulting thereof, unless such noncompliance was clearly not caused by fault of the distributor/customer.

To view a copy of the Terms and Conditions of Sale, go to: <https://PrestoLifts.com>  
(Find in About Us pull down menu)