



Trans-A-Dock, TAD Series
Surface Mount Loading Dock Lifts
(TAD30-606, TAD40-606, TAD50-606)
(TAD30-608, TAD40-608, TAD50-608)



Model: _____
Serial Number: _____
Date placed in service: _____

Presto Lifts Inc., 50 Commerce Way, Norton, MA 02766
800.343.9322 | Fax: 888.788.6496
service@prestolifts.com
www.PrestoLifts.com

**Owner
Manual**

Contents

If viewing this manual electronically, just left click any section below to immediately view that area.

To get back to the table of contents, just click in area to the outside of the left border.

1	INTRODUCTION.....	4
1.1	Specifications.....	4
1.2	Alternative Transfer Arrangements.....	5
1.3	Non-Standard Machines.....	5
1.4	Responsibilities of Owner and Users.....	6
1.5	Responsibilities of Operators.....	7
2	SAFETY.....	9
2.1	Safety Alert Symbols.....	9
2.2	Signal Words.....	9
3	LABELING.....	10
4	INSTALLATION.....	13
4.1	Key Components.....	14
4.2	General Machine Set-Up.....	15
4.3	Testing.....	20
4.4	Adjusting Down Speed Control Valve.....	21
5	OPERATION.....	22
5.1	Loading.....	23
6	MAINTENANCE & REPAIR.....	24
6.1	Maintenance Devices.....	25
6.2	Relieving Hydraulic Pressure.....	27
6.3	Periodic Maintenance.....	28
6.3.1	Weekly Inspections.....	29
6.3.2	Monthly Inspections.....	29
6.4	Replacement Parts.....	30
7	TROUBLESHOOTING.....	31

8	ELECTRICAL.....	35
8.1	Wiring Schematics - Single-Phase and Three-Phase	35
8.2	Typical Control Panel	37
8.3	Handheld Pushbutton Control Pendant	37
9	HYDRAULICS.....	38
9.1	Hydraulic Fluid	38
9.2	Typical Hydraulic Schematic.....	38
9.3	Typical Hydraulic Arrangement and Power Unit.....	39
9.4	Excess Flow Protectors	40
10	WARRANTY & CONTACT INFORMATION	41

⚠ WARNING
Cancer and Reproductive Harm - www.P65Warnings.ca.gov

This label (part # 10095524) is required by California Law. For more information visit: www.P65Warnings.ca.gov

1 INTRODUCTION

The information in this manual is for our standard machines, if you have any questions regarding the specifications and dimensions of your actual lift table, contact Presto Lifts Customer Service or Presto Lifts Sales if your order is being quoted or is in process.

1.1 Specifications

Model	Lift Capacity (lbs)	Platform Size W x L (in)	Axle Load Max Ends/Sides (lbs)	Lowered Height (in)	Vertical Travel (in)	Raised Height (in)
TAD-30-606	3,000	72 x 72	1,500	5	55	60
TAD-40-606	4,000		2,000			
TAD-50-606	5,000		2,500			
TAD-30-608	3,000	72 x 96	1,500			
TAD-40-608	4,000		2,000			
TAD-50-608	5,000		2,500			

Model	Standard Motor (HP)	Up Speed Approx. (sec)	Down Speed	Throw Over Bridge Plate (W x L) (in)	Throw Over Ramp (W x L) (in)	Ship Weight Approx. (lbs)
TAD-30-606	1-1/2	55	Adjustable with down speed flow control valve	60 x 18	60 x 30	4,000
TAD-40-606						
TAD-50-606						
TAD-30-608						4,100
TAD-40-608						
TAD-50-608						

Model:	Standard TAD Series Models
Hydraulic Fluid Type:	AW32 hydraulic fluid or equivalent or any other good quality oil with 150 SSU at 100° F and rust and oxidation inhibitors and anti-wear properties. If the lift will be used at ambient temperatures below 0°F, use a Type 15 aircraft hydraulic fluid.
Motor Full Load Amps:	17 A @ 115/1/60 Primary Voltage, 1-1/2 HP, 20 A ***
	9.4 A @ 208/1/60 Primary Voltage, 1-1/2 HP, 15 A ***
	8.5 A @ 230/1/60 Primary Voltage, 1-1/2 HP, 10 A ***
	5.3 A @ 208/3/60 Primary Voltage, 1-1/2 HP, 10 A ***
	4.8 A @ 230/3/60 Primary Voltage, 1-1/2 HP, 6 A ***
	2.4 A @ 460/3/60 Primary Voltage, 1-1/2 HP, 3 A ***
	*** - Recommended Overcurrent Protection
Operators/Passengers Permitted?	YES, with all handrails and flexible restraints in place
Features	Handheld Pushbutton - UP/DOWN
	Up Travel Limit Switch
	Excess Flow Protectors
<p>Note: The HPU Motor is powered and runs only when raising the platform. It is not powered when lowering.</p>	

1.2 Alternative Transfer Arrangements

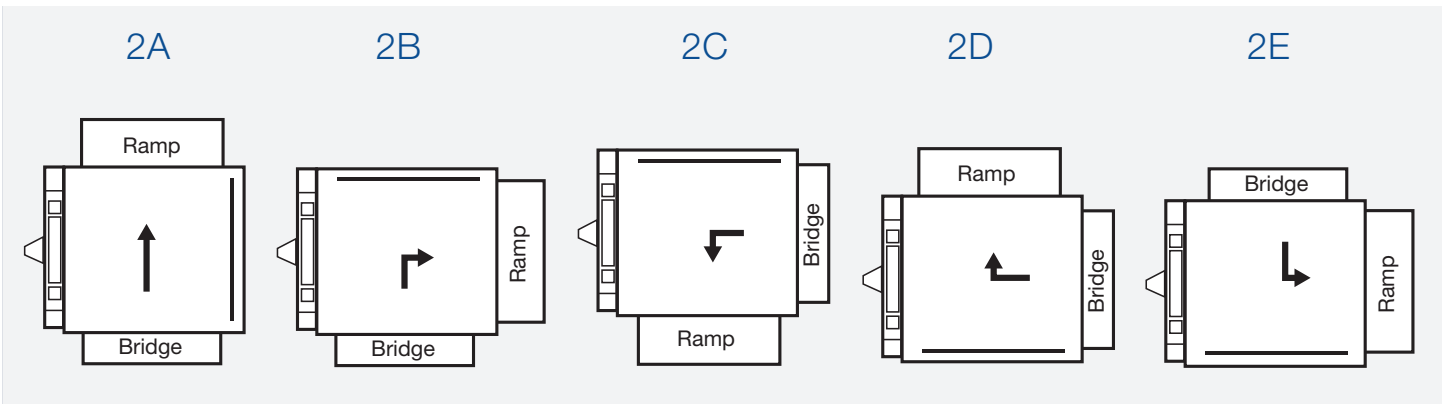

1.3 Non-Standard Machines

Non-standard machines have features not covered in this manual and can include but are not limited to such accessories as powered throw-over plates, aluminum throw-over plates, hydraulic fluid immersion heaters, unique handrail layouts, etc. If your dock lift has anything other than standard specifications, **contact Presto Lifts Customer Service for further assistance.**

1.4 Responsibilities of Owner and Users

Basic Principles - Owners/users shall apply sound principles of safety, training, inspection, maintenance to the expected operating environment. It shall be the responsibility of the owner/user to advise the manufacturer where deflection may be critical to the application.

Manuals - Owners/users shall keep and maintain a copy of the operating and maintenance manual(s) and ensure its availability to operating and maintenance personnel.

Inspection and Maintenance - It shall be the responsibility of the users to inspect and maintain the machine as required to ensure proper operation. The frequency of inspection and maintenance shall be based upon the manufacturer's recommendations and be compatible with operating conditions and the severity of the operating environment. Machinery that is not in proper operating condition shall be immediately removed from service until repaired. Maintenance and repairs shall be made by a qualified person and the repairs shall be in conformance with the manufacturer's recommendations.

Maintenance Safety Precautions - Before adjustments and repairs are started on the machine, the following precautions shall be taken as applicable:

1. Remove the load from the platform.
2. Lower platform to the full down position.
3. Relieve system pressure from all circuits before loosening or removing any components.
4. All controls in the "off" position and all operating features secured from inadvertent motion by brakes, blocks, or other means.
5. Disconnect power and follow established owner/user lockout/tag out policies.
6. Follow precautions and directions as specified by the manufacturer.

Replacement Parts - When parts or components are replaced, they shall be replaced with parts or components approved by the original manufacturer.

Maintenance Training - The user shall ensure only qualified personnel inspect and maintain the machine in accordance with the manufacturer's recommendations.

Operator Training - An owner/user, who directs or authorizes an individual to operate the machine shall ensure that the individual has been:

1. Trained in accordance with the manufacturer's operating manual.
2. Made aware of the responsibilities of operators as outlined in section 1.4 of this manual.
3. Retrained, if necessary, based on the owners/user's observation and evaluation of the operator.

Modifications and additions shall not be performed without the manufacturer's prior written approval. Where such authorization is granted, capacity, operation, and maintenance instruction plates, tags, or decals shall be changed accordingly.

1.5 Responsibilities of Operators

Basic Principles - Operators shall apply sound principles of safety and good judgment in the application, and operation of the machine with consideration given to its intended use and expected operating environment. Since the operator is in direct control of the machine, conformance with good safety practices is the responsibility of the operator. The operator shall make decisions on the use and operation with due consideration for the fact that his or her own safety as well as the safety of other personnel on or near the machine is dependent on those decisions.

General Training - Only personnel who have received general instructions regarding the inspection, application, and operation of machine, including recognition and avoidance of hazards associated with their operation, shall operate the machine. Such topics covered shall include, but not necessarily be limited to, the following issues and requirements:

1. A pre-start inspection
2. Responsibilities associated with problems or malfunctions affecting the operation of the machine
3. Factors affecting stability
4. The purpose of placards and decals
5. Workplace inspection
6. Safety rules and regulations
7. Authorization to operate
8. Operator warnings and instructions
9. Actual operation of the machine. Under the direction of a qualified person, the trainee shall operate the machine for a sufficient period of time to demonstrate proficiency in actual operation of the machine.

Pre-start Inspection - Before use each day or at the beginning of each shift, the machine shall be given a visual inspection and functional test including but not limited to the following:

1. Operating and emergency controls
2. Safety devices
3. Hydraulic system leaks
4. Electrical cables and wiring harness
5. Loose or missing parts
6. Nameplates, precautionary and instructional markings and/or labeling
7. Guarding system
8. Items specified by the manufacturer

Problem or Malfunctions - Any problems or malfunctions that affect the safety of operations shall be repaired prior to the use of the machine.

Before Operations - The operator shall:

1. Read and understand the manufacturer's operating instruction(s) and user's safety rules or have them explained.
2. Understand all labels, warnings, and instructions displayed on the machine or have them explained.

Workplace Inspections - Before the machine is used and during use, the operator shall check the area in which the machine is to be used for possible hazards such as, but not limited to:

1. Bumps, floor obstructions, and uneven surfaces
2. Overhead obstructions and electrical hazards
3. Presence of unauthorized persons
4. Other possible unsafe conditions as noted in the operating manual.

Operator Warnings and Instructions - The operator shall ensure the operation of the machine is in compliance with the following:

1. **Guarding system** - Guarding shall be installed and positioned, and access gates or openings shall be secured per the manufacturer's instructions (If applicable).
2. **Distribution of load** - The load and its distribution on the platform shall be in accordance with the manufacturer's rated capacity for that specific configuration.
3. **Maintaining overhead clearance** - The operator shall ensure that adequate clearance is maintained from overhead obstructions and energized electrical conductors and parts.
4. **Point of Operation** - The operator shall not place any part of their body under the platform.
5. **Precaution for moving equipment** - When other moving equipment or vehicles are present, special precautions shall be taken to comply with the safety standards established for the workplace.
6. **Reporting problems or malfunctions** - The operator shall immediately report to a supervisor any problem(s) or malfunction(s) that become evident during operation. The operator shall ensure all problems and malfunctions that affect the safety of operations are repaired prior to continued use.
7. **Capacity limitation** - Rated capacity shall not be exceeded when loads are transferred to the platform.
8. **Work area** - The operator shall ensure the area surrounding the machine is clear of personnel and equipment before lowering the platform.
9. **Securing the machine** - The operator shall comply with the means and procedures provided to protect against use by an unauthorized person(s).
10. **Altering safety devices** - Safety devices shall not be altered or disabled.
11. **Modifications** or alterations of the machine or the fabrication and attaching of frameworks or the mounting of attachments to the machine or the guarding system shall only be accomplished with prior written permission of the manufacturer.
12. **Assistance to the operator** - If an operator encounters any suspected malfunction or any hazard or potentially unsafe condition relating to capacity, intended use, or safe operation, the operator shall cease operation of the machine and request further instruction from the owner/user.
13. **Problems or malfunctions** - Any problem(s) or malfunction(s) that affect the safety of operations shall be repaired prior to the use of the machine.

2 SAFETY

All personnel installing, operating, and maintaining this machine shall read and understand this manual. For questions or concerns contact the manufacturer.

This machine shall be installed, operated, and maintained by trained and/or qualified personnel only.

2.1 Safety Alert Symbols



A symbol that indicates a hazard. It is composed of an equilateral triangle surrounding an exclamation mark. The safety alert symbol is only used on hazard alerting signs. It is not used on safety notice and safety instructions signs.

A – For use with **DANGER** signal word; (safety white triangle, safety red exclamation mark, safety red background)

B – For use with **WARNING** signal word; (safety black triangle, safety orange exclamation mark)

C – For use with **CAUTION** signal word; (safety black triangle, safety yellow exclamation mark)

D – For use with **DANGER, WARNING, or CAUTION** signal words; (**D** is a safety yellow triangle with a safety black border and safety black exclamation mark;

2.2 Signal Words

DANGER



DANGER Indicates a hazardous situation that, if not avoided, will result in death or serious injury.

WARNING



WARNING Indicates a hazardous situation that, if not avoided, could result in death or serious injury.

CAUTION



CAUTION Indicates a hazardous situation that, if not avoided, could result in minor or moderate injury.

NOTICE







NOTICE Indicates information considered important, but not hazard-related (e.g., messages relating to property damage).

3 LABELING

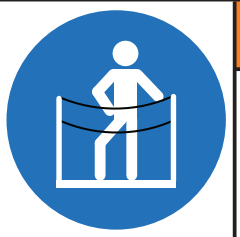
This machine has labeling to indicate potential hazards this machine may pose when operating and/or maintaining the machine. All labels must be legible. If any label is missing, damaged, or otherwise illegible contact the manufacturer for replacement labels.

Item 1	Located on platform skirts		
Part No. 2986306		Quantity: 4 ea	BK-LD DCL 2.00X17.00
<p>DANGER Crush and Fall Hazards Read and understand all instructions before operating or servicing this lift.</p> <p>Do NOT enter under this platform unless it is mechanically locked.</p>			
Item 2	Located on all both sides		
Part No. 5904643		Quantity: 2 ea	BK-LD DCL 2.00X12.00 A DANGER
<p>DANGER To avoid bodily injury, Read and understand all instructions before operating or servicing this lift.</p> <p>Do NOT put hands or feet under the platform.</p>			
Item 3	Located on control panel	Item 4	Labels to be located where visible on maintenance devices whether in storage or deployed positions
Part No. 10047672		Quantity: 1 ea	Part No. 2991927
BK-LD DCL 3.00X1.50 ARC FLASH AND SHOCK		Quantity: 4 ea	
<p>DANGER Shock and arc flash explosion hazards. Follow ALL requirements in NFPA 70E for safe work practices and for Personal Protective Equipment. Hazardous Voltage. Will cause severe injury or death. Turn off and lock out system power before servicing. DO NOT operate machine with electrical panel doors opened or covers removed.</p>		<p>FOR MAINTENANCE ONLY</p> <p>2991927</p>	

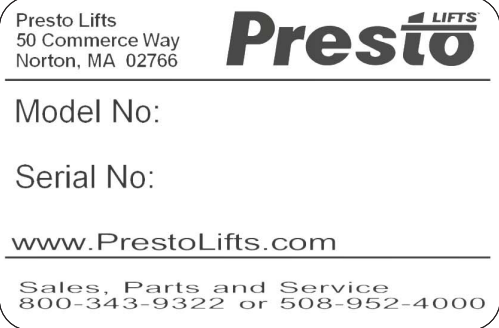
Item 5	Located on base frame		Item 6	Located on flow control	
Part No. 2921026		Quantity: 1 ea	Part No. 2998365		Quantity: 1 ea
BK-LD DCL 2.00X4.50 NOTICE! DO NOT RAISE			LD DCL 2.50X5.00 PROPER INSTALLATION IS		
<h2 style="text-align: center; background-color: #0056b3; color: white; padding: 5px;">NOTICE</h2> <p>Do not raise to full upper physical stops. Upper travel limit switch must be connected and properly adjusted to prevent structural damage.</p> <p style="text-align: right; font-size: small;">2921026</p>			<h2 style="text-align: center; background-color: #0056b3; color: white; padding: 5px;">NOTICE</h2> <p>Proper installation is essential to the performance of this product. Leveling and securing the base frame along with other important information is within your owner's manual. If the owner's manual is not available, log on to the company's website to download a free copy.</p> <p style="text-align: right; font-size: small;">2998365</p>		
Item 7	Located on platform handrails				
Part No. 10086440		Quantity: 2 ea	LD DCL 2.00X8.00 DO NOT OPERATE WITHOUT		
					<h3 style="text-align: center; background-color: #ff8c00; color: white; padding: 5px;">⚠ WARNING</h3> <p>Do NOT operate without personnel guarding. Serious injury or death could occur.</p> <p style="text-align: right; font-size: x-small;">10086440</p>
Item 8	Machine control power label located on control panel and junction box		Item 9	Machine primary power label located on control panel and junction box (other voltages have different part #s)	
Part No. 2986998		Quantity: 2 ea	Part No. 2987000		Quantity: 2 ea
BK-LD DCL 1.25X1.75 CONTROL, 24V 1 PHAS			BK-LD DCL 1.25X1.75 POWER, 115 1 PHAS		
<h1 style="text-align: center; background-color: #ffcc00; padding: 20px;">CONTROL</h1> <h2 style="text-align: center; background-color: #ffcc00; padding: 20px;">24 VOLTS 1 PHASE</h2> <p style="text-align: right; font-size: small;">2986998</p>			<h1 style="text-align: center; background-color: #ffcc00; padding: 20px;">POWER</h1> <h2 style="text-align: center; background-color: #ffcc00; padding: 20px;">115 VOLTS 1 PHASE</h2> <p style="text-align: right; font-size: small;">2987000</p>		

Item 10	Located on platform (other capacities have different part #s)	Item 11	Located on platform skirt
Part No. 2998442	Quantity: 4 ea	Part No. 10095524	Quantity: 1 ea
BK-LD DCL 1.25X2.75 CAPACITY 5000 LBS		LD WARNING CANCER AND REPRODUCTIVE	
			
Item 12	Located on leg set and under platform	Item 13	Located on platform skirts
Part No. 10079930	Quantity: 2 ea	Part No. C180N	Quantity: 2 ea
LD DCL 2.00X3.00 SERIAL ID BL		LD 1.67X7.00 PRESTO ALPHA	
			
Item 14	Located on fluid reservoir	Item	Intentionally left blank
Part No. 2986997	Quantity: 1 ea	Part No.	Quantity:
BK-LD DCL 1.50X5.50 TANK TO BE FULL ONLY			
			

4 INSTALLATION

Installation of this machine shall be performed by trained and/or qualified personnel only. The owner/ installer is responsible for obtaining any necessary permissions and/ or permits. Follow all applicable codes and ordinances. Read and understand all safety and installation information in this manual.

Before installation, remove all shipping materials and verify all components on the packing list were received. Inspect the machine, all components, wiring and electrical connections, hydraulic hoses and fittings for damage. If components are missing or damage is found contact the manufacturer before continuing installation.

DANGER

High Voltage: Electrical service and installation must be performed by trained and/or qualified personnel. Lock-out/tag-out the power source before installation.

Electric motors can create sparking, do not install in an area where flammable materials are present.

Never enter beneath the platform unless the machine is unloaded and secured against lowering using the maintenance devices. If unable to engage the maintenance devices the platform must be secured against lowering by other means. See Maintenance Devices section.

All electrical components and the hydraulic power unit must be protected from wet and/or dirty environments unless specifically configured for such environments.

Pinch points and crush hazards exist when moving and transporting the machine. Do not enter under any equipment while moving or transporting. Keep hands, feet, and loose clothing away from moving equipment.

This machine must be installed on a solid, stable, level surface or machine will be unstable which can lead to damage to the lift table and lead to injury. Do not install on asphalt or other unstable surface.

Ensure portability flip down wheels are in the storage position before operating.

Use appropriate lifting device to lift the machine. Use a load spreader to lift the machine. Lift the machine using the provided lifting eyes only. Do not lift the machine by the platform.

This machine is portable and does not need to be lagged down for operation.

The TAD Series of lifts have been primarily designed for loading dock applications. The most important advantage of the TAD Series is that it is fully adjustable in height. The installation of this lift provides full flexibility, allowing you to load and unload at any truck bed elevation within the lift's travel range.

4.1 Key Components

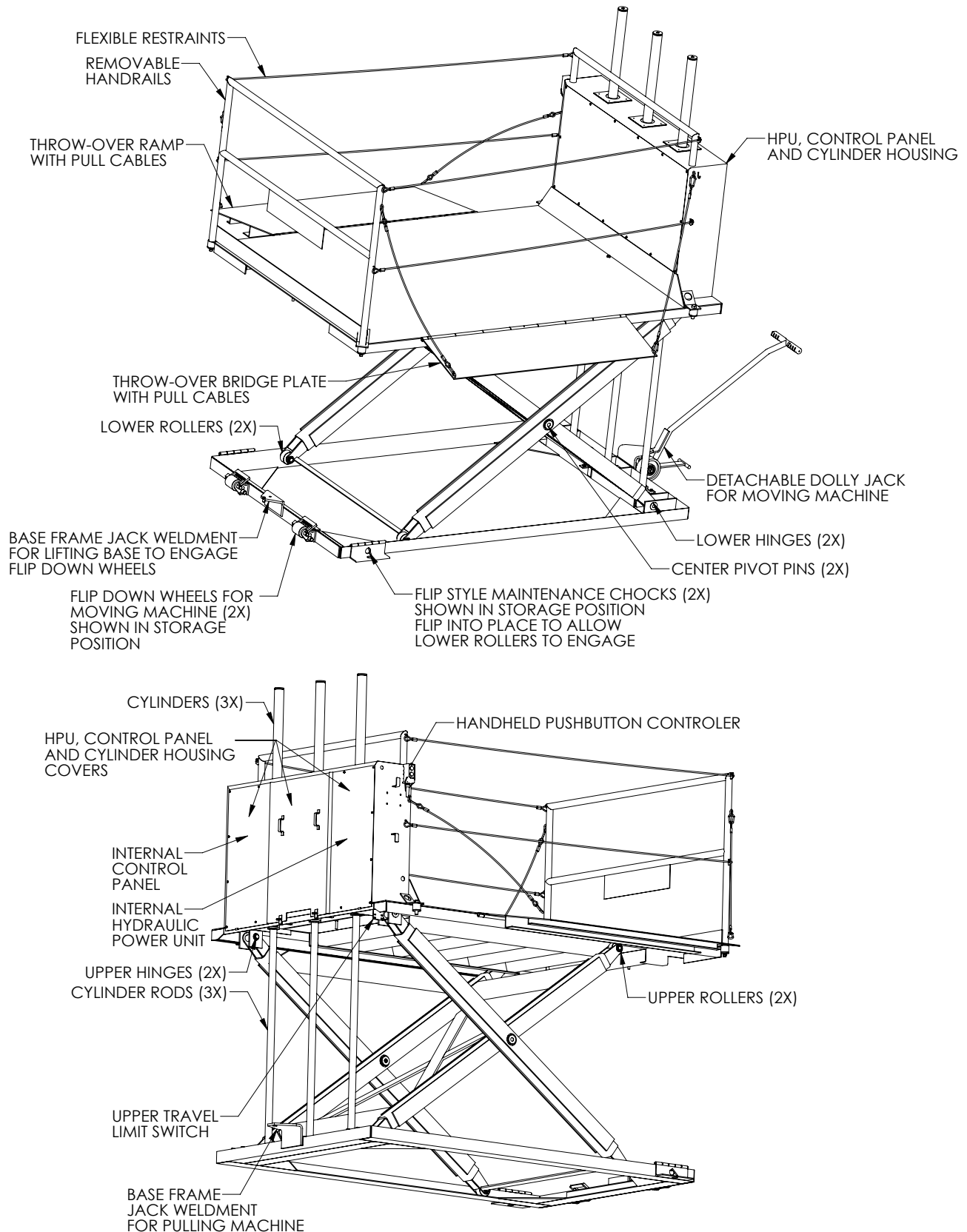

4.2 General Machine Set-Up

1. Ensure the area the TAD Series Lift will sit on is flat and level.
2. This machine comes with (4) removeable lifting eyes.

NOTICE

Before removing the lift from the skid, make sure that the (2) shipping bolts in the platform that hold the platform and base frame together are in place.

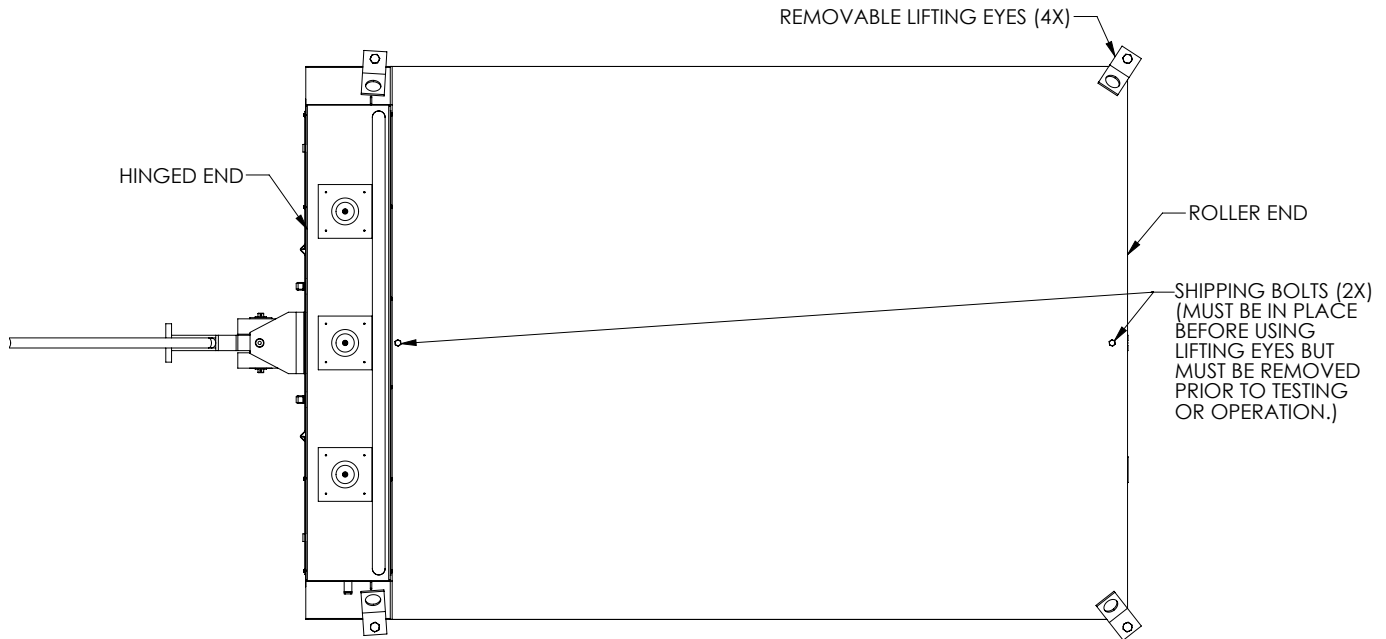

3. Remove the handrails and flexible restraints from the skid.
4. Remove the lift from the skid using all (4) lifting eyes with spreader bars and set in place as close to the desired user location as possible. The flip down wheels should be in their storage position, but if not, refer to images later in this section before lowering to floor.

NOTICE

Weight of complete machine: 4,000 lbs. approximate, based on model

5. Once the lifting eyes are no longer needed, remove them and the bolts/washers that are holding them in place.
6. Also remove the two bolts that secure the platform and base frame together after transporting the machine using the lifting eyes. Store these and the bolts washers and lifting eyes from the step above in a safe place for future use.

NOTICE

Not removing the (2) shipping bolts in the platform that hold the platform and base frame together could damage the machine if not removed before testing and operation.

- The portability kit that comes with the lift may be used to move the lift table without the use of a fork truck if needed.

CAUTION

When lifting the base frame end, ensure that your feet do not enter beneath the base frame.

- To engage the portability kit, lower and lock in the two flip down wheels on the roller end of the base frame. To do this, tilt the dolly jack into place and align the hole on the jack with the alignment pin on the base frame weldment at the center of the roller end. Pressing down on the jack handle will result in raising the base frame. Both wheels should lower and lock in place by themselves before lowering the base frame and disengaging the dolly jack with the weldment.

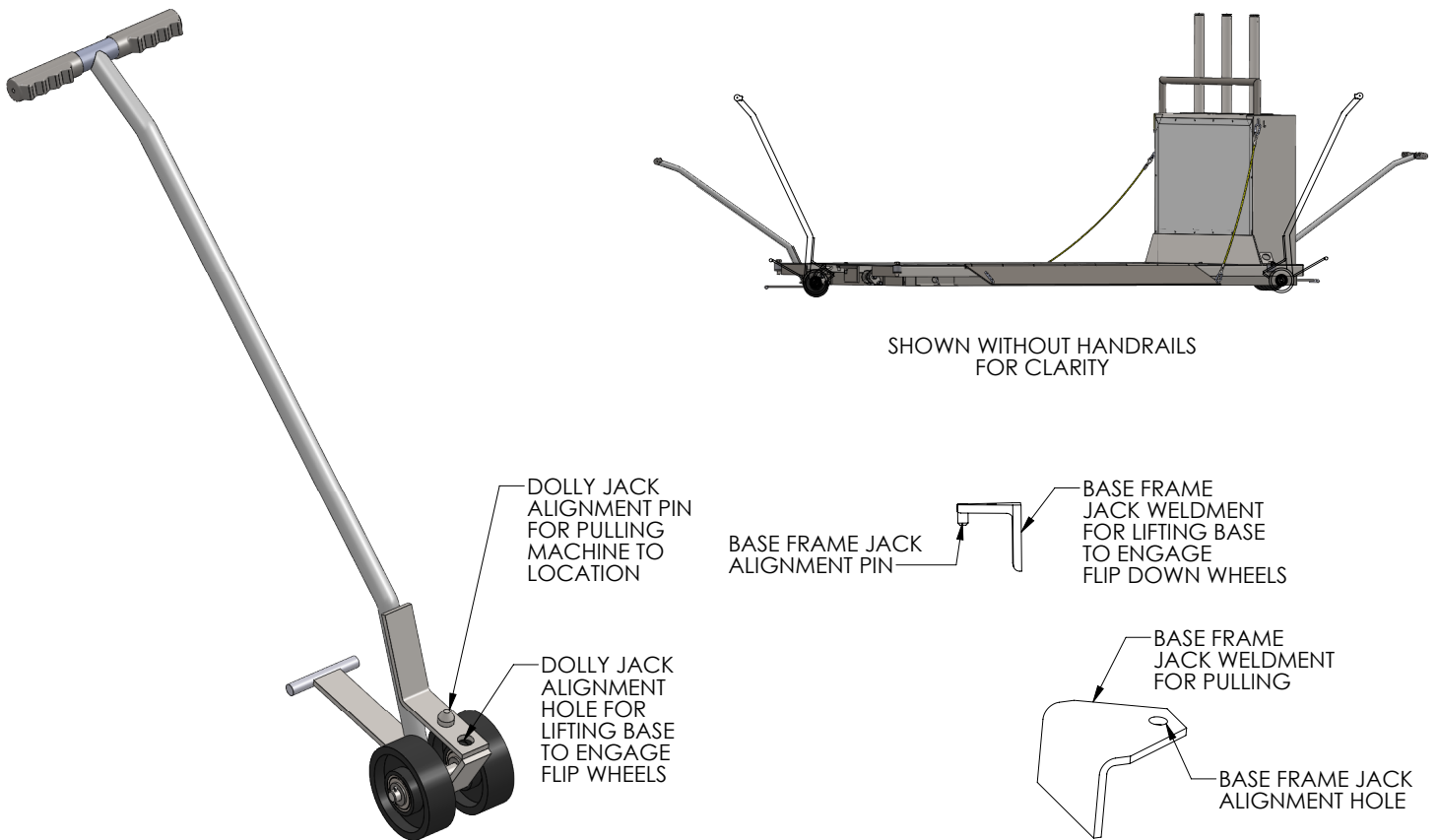
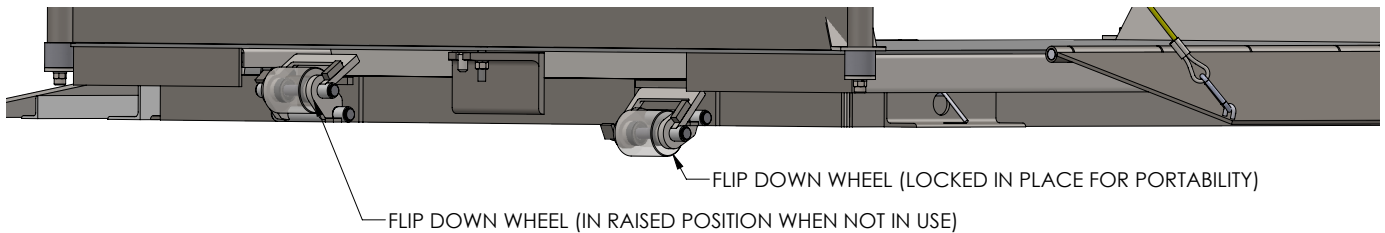

- Engage the dolly jack on the hinged end weldment in a similar manner by tilting the dolly jack into place aligning the pin on the jack with the alignment hole on the base frame weldment, press down to engage and pull lift table to desired location.



Flip Down Wheels in Storage Position, Dolly Jack Not Yet Engaged



Flip Down Wheels in Latched Position, Dolly Jack Engaged



*Flip Down Wheels in Free Position, Base Frame Raised, Dolly Jack Engaged
(Once base frame is lowered to floor, Flip Down Wheels will rotate up to Storage Position)*



Use foot to aid in Engaging Dolly Jack



Dolly Jack Engaged, Flip Wheels in Latched Position, and Ready to Relocate

10. Engage the dolly jack again with the weldment at the center of the roller end and reposition the flip down wheels back into their non-use storage positions by quickly shaking the dolly jack handle up and down a bit until the flip down wheel latches rotate back.
11. Once wheels are no longer latched, lower and disengage the dolly jack from the roller end weldment. The jack may be stored in a convenient location for future use.
12. Lagging will not be necessary for this portable lift.
13. Install handrail base posts into the receiving pockets (where lifting eyes were removed from) on roller end of platform. See **Key Components** section.
14. Install flexible restraints to handrails and attach pull cables to throw-over plate, ramp, handrails and HPU, control panel and cylinder housing.
15. The internal control panel, the handheld pushbutton pendant, and hydraulic power unit are prewired from the factory however house power will need to be provided to the control panel.
16. For 115/1/60, 208/1/60 or 230/1/60, house power will connect to the 1L1 and 3L2 connection points at the top of the motor contactor and house ground to a green and yellow ground block terminal in the control panel. For recommended overload protection, see **Electrical** section.

17. For 208/3/60, 230/3/60 or 460/3/60, house power will connect to the 1L1, 3L2 and 5L3 connection points at the top of the motor contactor and house ground to a green and yellow ground block terminal in the control panel. For recommended overload protection, see **Electrical** section.
18. Once the lift is in position and properly set up electrically, the lift is ready to be powered up.
19. The lift is now ready for testing.

CAUTION

Ensure portability flip down wheels are in the storage position before operating.

The load capacity rating as labeled on your TAD designates the maximum lifting capacity with a uniformly distributed load. This capacity must never be exceeded, as permanent damage may result.

Consult the factory before any modification is performed in the field. **NOTE: Any modification of the lift in the field, without the express written consent of Presto Lifts, will void any and all warranties.**

Each cylinder has an excess flow protector valve to allow the lift to descend slowly in the event of a catastrophic hose failure.

The TAD is furnished with constant pressure (press and hold type) pushbutton controls. Always remember that the motor runs only when the UP pushbutton is pressed and the down valve solenoid is energized only when the DOWN pushbutton is pressed.

1. Clean any debris; wipe up any oil and ensure all operators are fully trained on the operation of the lift.
2. Remove any load on the platform.
3. Turn on house power.
4. Pressing the UP pushbutton starts the motor, (see **Wiring Schematic** section) which in turn runs the hydraulic pump. The cylinders begin to extend and the platform starts to rise. The platform will rise as long as the UP pushbutton is pressed and the UP LIMIT SWITCH is not activated. On releasing the pushbutton, the platform ceases to rise and will remain at that particular elevation. If the platform did not raise, see **Troubleshooting** Section.
5. Press the UP pushbutton to raise the platform to full travel height, approximately 60" from the floor to the platform surface. At this point, the UP LIMIT SWITCH should be triggered, the platform should have stopped raising and the motor should have stopped running. Pressing the UP pushbutton at this position will have no effect. The platform will remain stationary at the desired elevation. If the platform is approximately 60" off the floor, and the motor shuts off with the UP pushbutton still being pressed, the UP LIMIT SWITCH is operating correctly. If the motor does not shut off when pressing the UP pushbutton after the platform has reached the 60" height off the floor, the limit switch is not operating correctly. See **Troubleshooting** section.
6. Press the DOWN pushbutton. The down valve solenoid will energize and open the down valve. The cylinders start retracting as the oil returns to the reservoir and upon releasing the pushbutton, the platform ceases to lower remaining at that particular elevation.

7. Press the DOWN pushbutton to lower the platform to fully lowered height of 5" from the floor to the platform surface.
8. Cycle the lift a few times.
9. If the down speed is too slow or too fast, the down speed flow control valve may be opened or closed more to allow a faster or slower down speed. See **Adjusting Down Speed Control Valve** section.
10. Place a maximum load onto the platform.
11. Repeat steps 4 through 9.
12. The TAD is now ready for operation.

NOTICE

- ⋮
- ⋮ **The hydraulic pump is equipped with a pressure relief valve, do not adjust, it is**
- ⋮ **there to protect the lift table, do not exceed labelled capacity.**
- ⋮

4.4 Adjusting Down Speed Control Valve

To allow the platform to lower at a different speed, loosen the jam nut and turn the adjustable down speed control valve knob clockwise to allow the platform to lower more slowly, and counter-clockwise to allow the platform to lower more quickly. Tighten the jam nut after adjusting. For location, see **Hydraulic Arrangement and Power Unit** section.

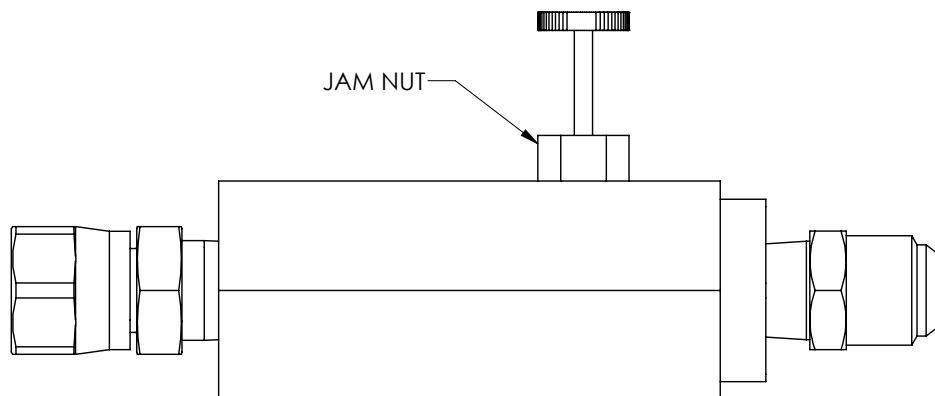

5 OPERATION

Before operating this machine, read and understand this manual. Inspect the machine, electrical and hydraulic components, controls and cords for excessive wear and/or damage. **If excessive wear or damage is found, remove the machine from service and contact maintenance personnel.** Inspect all precautionary labeling. If any label is missing or illegible contact the manufacturer for replacement labels. Ensure area is free of debris.

DANGER

Only authorized, trained and qualified personnel shall operate this machine. Personnel operating this machine must read and understand this manual.

Never enter beneath the platform unless the machine is unloaded and secured against lowering using the maintenance device. See Maintenance Devices section.

Keep hands, feet, and loose clothing away from moving parts during operation.

This machine must be installed on a solid, stable, level surface or machine will be unstable which can lead to damage to the lift table and lead to injury. Do not install on asphalt or other unstable surface.

Verify the area around the machine is clear of debris and/or personnel before operating.

Notify maintenance personnel in the event of a malfunction or unusual noises. Do not continue to operate the machine until the cause of the malfunction or unusual noise has been determined and remedied.

Always keep power and control cords clear of foot and vehicle traffic during operation.

During operation, operator must be in view of the machine at all times.

When not in use the platform is to be in the fully lowered position.

Ensure portability flip down wheels are in the storage position before operating.

The load's center of mass must be centered on the platform. Uneven or off-center loading may cause excessive wear or permanent damage.

For use with two wheel dollies, hand carts, and hand pallet trucks only.

The load capacity rating as labeled on your TAD designates the maximum lifting capacity with a uniformly distributed load. This capacity must never be exceeded, as permanent damage may result.

Before each use, ensure area is clear of debris and there is no standing water under the lift table. Inspect the machine for excessive wear or damage and ensure all precautionary labeling is legible. Inspect railings, verify flexible restraints and throw-over plate and ramp pull cables are in place and in good condition. Verify pushbutton switch and cord are functioning and are not damaged.

NOTICE

⋮
⋮ **Do not continue to press the UP pushbutton if the platform is not rising. You can permanently damage the motor or pump by doing so unless the UP LIMIT SWITCH is activated, which would not cause damage to the motor or pump as the switch would shut off the motor.**

⋮
⋮ **Before raising or lowering, raise throw-over plate(s) to avoid damaging them.**

The TAD is furnished with a press and hold type handheld pushbutton control pendant hung on the HPU/control panel housing.

To raise the machine, press and hold the UP pushbutton on the handheld pushbutton controls. Release the pushbutton when the platform is at the desired height.

An UP LIMIT SWITCH will automatically turn off the motor when the platform reaches approximately 60" from the floor to the platform surface. If the motor still runs while the UP pushbutton is pressed and the 60" height is reached, contact maintenance for inspection.

To lower the machine, press and hold the DOWN pushbutton on the controls. Release the pushbutton when the platform is at the desired height.

5.1 Loading

The Center of Gravity (CG) of all loads must be centered on the platform when lift is in motion. Uneven loading can lead to excessive wear and premature failure. Any regular, uneven loading must be offset by a counterweight installed on the opposite side of the platform. The combined load must not exceed the rated capacity.

CAUTION

⋮
⋮ **Do not load or unload the lift table while moving.**

⋮
⋮ **Loads that may shift must be secured before operating.**

⋮
⋮ **Do not exceed maximum load capacity of lift table.**

 DANGER

High Voltage: Electrical service and installation must be performed by trained and/or qualified personnel. Disconnect and lock out electrical supply before performing any maintenance or repair.

Electric motors create sparks. Do not service the power unit in an area where flammable gases may be present.

Never enter beneath the platform unless the machine is unloaded and secured against lowering using the maintenance device. If unable to engage the maintenance device the platform must be secured against lowering by other means. See Maintenance Devices section.

All electrical components and the hydraulic power unit must be protected from wet and/or dirty environments unless specifically configured for such environments.

Keep hands, feet, and loose clothing away from moving parts during operation.

Only trained, authorized and qualified personnel shall perform maintenance or repair of this machine. Personnel repairing or maintaining this machine must read and understand this manual.

Pressurized fluids can penetrate skin and cause severe injury or death. Always use proper personal protective equipment when repairing or maintaining pressurized systems. Relieve hydraulic system pressure before performing any maintenance on the hydraulic system. See Relieving Hydraulic Pressure section.

Pinch points and crush hazards exist when moving and transporting the machine. Do not enter under any equipment while moving or transporting. Keep hands, feet, and loose clothing away from moving equipment.

This machine must be installed on a solid, stable, level surface or machine will be unstable and can lead to injury. Do not install on asphalt or other unstable surface.

Do not adjust the hydraulic pressure relief valve. This valve is pre-set, and adjustment may cause the machine to fail.

⚠ DANGER

The supplied maintenance devices are designed to support the weight of an **UNLOADED** machine only. Failure to remove the load before engaging the maintenance device may result in failure and allow the machine to fall unexpectedly.

Flip Down Wheels must be in storage position before engaging maintenance devices.

Before performing any maintenance or repair:

1. Remove any load on the platform of the machine.
2. Verify that all personnel and debris are clear of the work area.
3. Raise the lift to a high enough position to allow the maintenance devices to engage.
4. Flip both maintenance devices into lower roller tracks from their storage position.

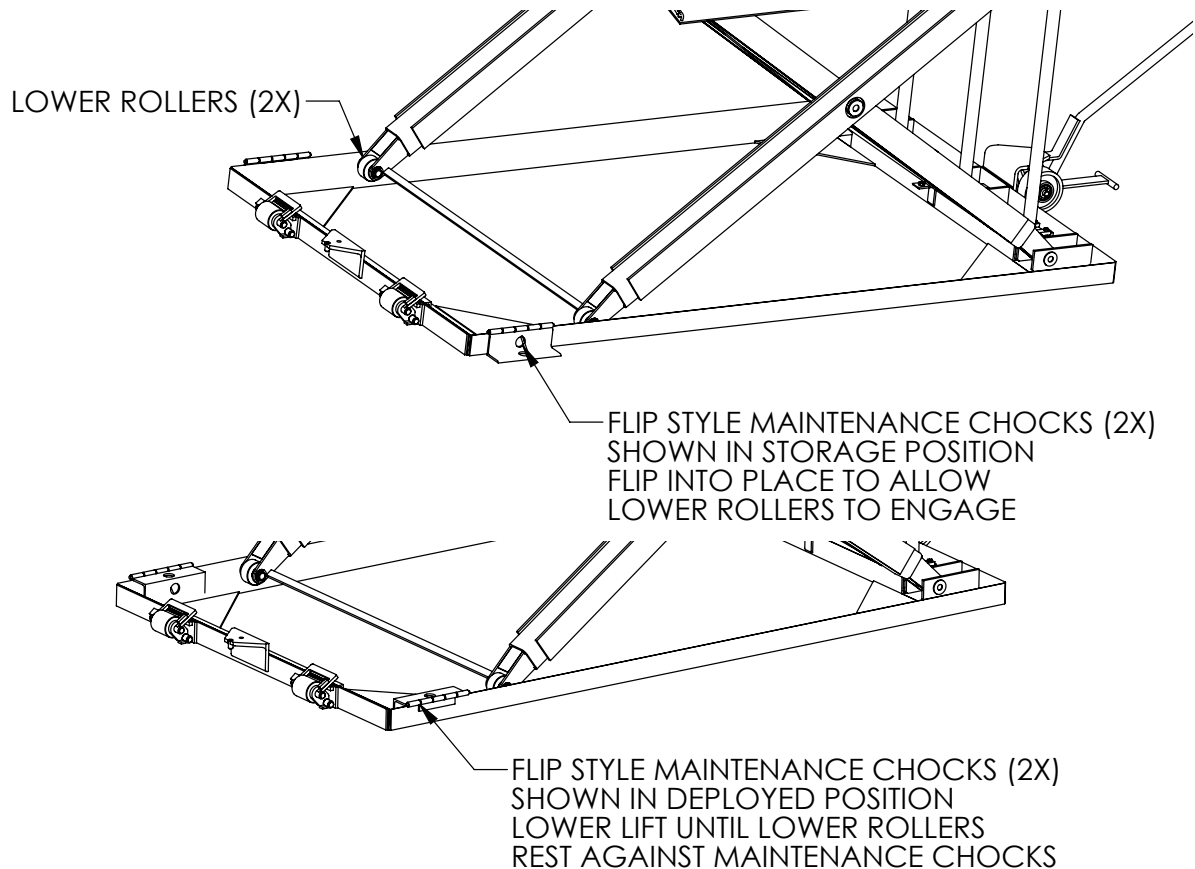

5. Slowly lower the machine until the lower rollers are resting against both maintenance devices and the weight of the platform is fully supported. Continue to hold the down pushbutton for five to ten seconds after the platform stops to relieve hydraulic system pressure.
6. Disconnect electrical supply and lock out the machine to prevent unintended actuation of the machine.

7. After maintenance or repair is complete, verify all tools, debris, and personnel are clear of the area. Clean up any spills. Re-energize the machine.
8. Raise the lift to a high enough position to allow the maintenance devices to disengage.
9. Disengage the maintenance devices by flipping them back into their storage locations.
10. Lower the machine to the fully lowered position.
11. Test for proper operation.

6.2 Relieving Hydraulic Pressure

If the machine is operating normally, hydraulic system pressure can be relieved by pressing the DOWN pushbutton, lowering the platform to the fully lowered position or onto the maintenance devices and continuing to hold the pushbutton for five to ten seconds after the platform stops.

⚠ DANGER

High Voltage: Electrical service disconnecting and connecting must be performed by trained and/ or qualified personnel. Disconnect and lock out electrical supply before performing this procedure.

Never enter beneath the platform unless the machine is unloaded and secured against lowering using the maintenance device. See Maintenance Devices section.

Pressurized fluids can penetrate skin and cause severe injury or death. Always use proper personal protective equipment when repairing or maintaining pressurized systems.

Remove load from platform before engaging maintenance devices and before attempting to loosen any fitting on the pressure line.

Relieve hydraulic system pressure before performing any maintenance on the hydraulic system.

In emergency situations if the hydraulic power unit is not receiving power and the platform is in a raised position, hydraulic system pressure may be relieved by the following steps.

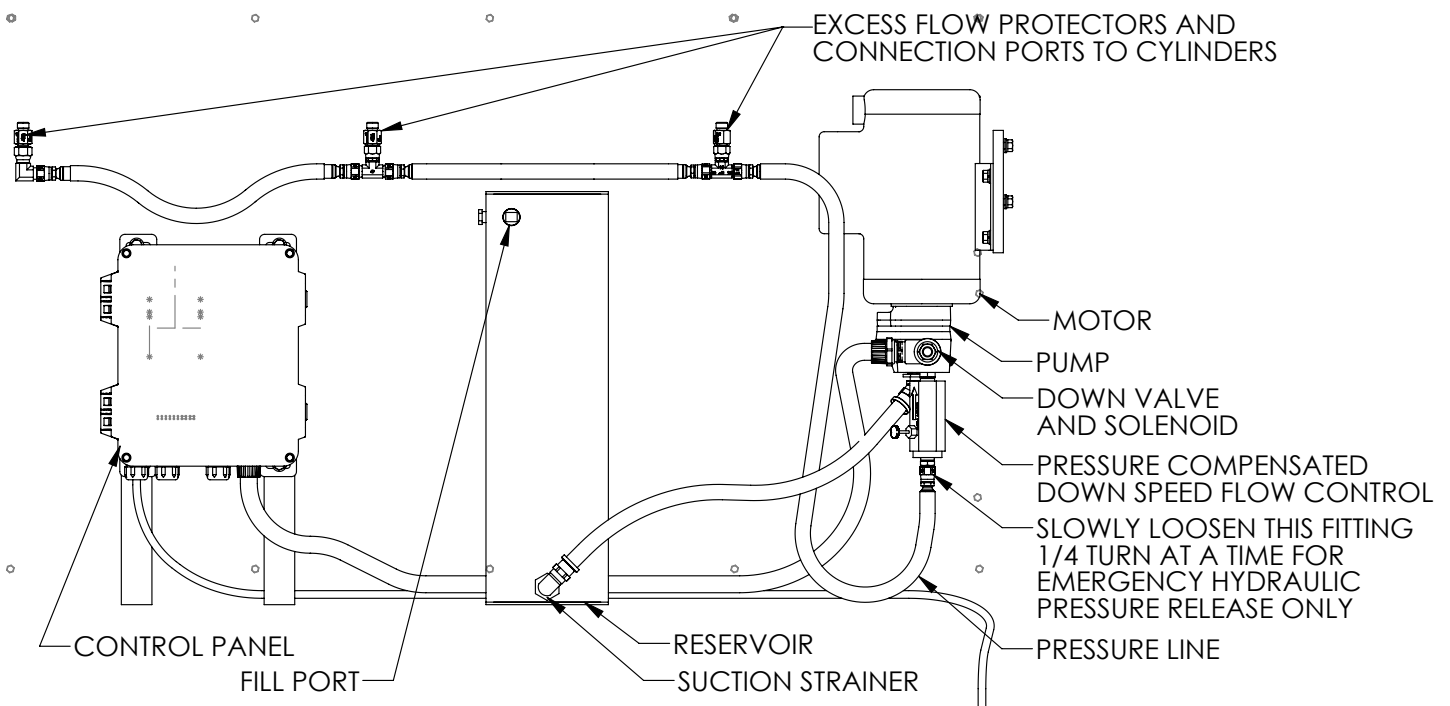

1. Disconnect electrical supply and lock out the machine to prevent unintended actuation of the machine.
2. Verify that all personnel and debris are clear of the work area, this lift may descend quickly as the pressure is relieved.
3. If a load is currently on the platform, remove it.
4. If the platform is high enough to flip the maintenance devices into place, do so.
5. Remove back panel housing covers.
6. It will be necessary to slowly release the hydraulic fitting on the cylinder side of the down speed control valve at the HPU.
7. Since the back panel housing will be at an elevated level, ensure that any release of hydraulic fluid is not at eye level.
8. Before beginning to release the fitting, use a clean container and rags to direct the hydraulic fluid accordingly.
9. Loosen fitting about a 1/4 turn at a time and observe leaking fluid. Allow slow gradual release of fluid and ensure area around lift table is free from personnel and obstructions.
10. Allow the platform to lower onto the maintenance devices (ensure load has been completely removed) or to the fully lowered position. Once the fluid is no longer escaping the partially loosened fitting, tighten accordingly.
11. Clean up any spills. Re-energize the machine.
12. If platform is on the maintenance devices, refer to steps 8 through 10 of the **Maintenance Devices** section. If the platform will not raise, add just enough hydraulic fluid to the reservoir to raise the platform high enough to disengage the maintenance devices.
13. Once the platform is at the fully lowered position, refill the reservoir to about 1" below tank fill port. Do not overfill.
14. Test for proper operation.

6.3 Periodic Maintenance

NOTICE

⋮
⋮ **See images in Key Components section.**
⋮

Before each use, ensure area is clear of debris and there is no standing water under the lift table. Inspect the machine for excessive wear or damage and ensure all precautionary labeling is legible. Inspect railings, verify flexible restraints and throw-over plate and ramp pull cables are in place and in good condition. Verify push button switch and cord are functioning and are not damaged.

Raise the lift and engage the maintenance devices before beginning any inspection or work on the unit.

6.3.1 Weekly Inspections

- Inspect upper and lower leg rollers, center pivot pins and bushings, and leg hinge pins and bushings for excessive wear or damage. Repair or replace as necessary.
- Inspect machine for loose or broken fasteners. Repair or replace as necessary.
- Inspect labeling. If any label is damaged or otherwise illegible contact the manufacturer for replacement labels.

6.3.2 Monthly Inspections

- Perform Weekly Maintenance.
- Apply a light oil or PTFE lubricant to non-greased pivot points, and upper and lower rollers, including flip down wheels, associated pivot points and dolly jack wheels.
- Never grease leg roller surfaces or tracks.
- Remove rear panel covers.
- Inspect all hydraulic hoses and fittings for fluid leaks, wear or damage. Repair or replace as necessary.
- Inspect hydraulic fluid in reservoir. It should be changed if the fluid darkens, turns cloudy or milky or has a burnt odor or becomes gritty. See **Hydraulic Fluid** and **Hydraulic Arrangement and Power Unit** sections.
- Inspect hydraulic fluid level. It should be about 1" below tank fill port with the lift in fully lowered position. Add fluid as required. See **Hydraulic Fluid** and **Hydraulic Arrangement and Power Unit** sections.
- Inspect roller bushings, pins, clevis and pivot points for wear.
- Inspect cylinders and their mounts on both ends.
- Inspect retaining rings at all pins, pivot points and clevises.
- Listen for unusual noise. See **Troubleshooting** section.
- Inspect all electrical wiring and connections. Repair or replace as necessary.
- Inspect upper travel limit switch. Repair, replace, or adjust as necessary.
- Inspect handheld pushbutton control pendant and cord. Repair, replace, or adjust as necessary.
- Apply a generous coating of Industrial High Performance Lubricant with PTFE, BOESHIELD T-9 Rust & Corrosion Protection Waterproof Lubricant or Metaflux 70-81 Titanium Corrosion Inhibitor and Lubricant using a spray can into the throw-over plate and ramp hinge pipes. Work the throw-over plate and ramp back and forth a few times and spray again if necessary to allow hinges to move satisfactorily. Immediately and completely remove any lubricant residue from the top and bottom surfaces of the throw-over plate, ramp, platform, flip down wheels and dolly jack to avoid personnel slippage.
- Replace rear panel covers.

6.4 Replacement Parts

Presto Lifts has carefully chosen the components in your lift to be the best available for the purpose. Replacement parts should be identical to the original equipment. Presto Lifts will not be responsible for equipment failures resulting from the use of incorrect replacement parts or from unauthorized modifications of the machine.

Presto Lifts will gladly supply you with replacement parts for your Presto Lifts equipment. With your order, please include the model number and the serial number of the lift. You can find these numbers on the name plate, which is located on the crossbar at the base of the cylinder(s). When you are ordering parts for a cylinder, also include the cylinder number. This is stamped on the base of the cylinder housing.

To order replacement parts, please call the Parts Department. See **Warranty & Contact Information** section. Parts are shipped subject to the following terms:

- FOB factory
- Returns only with the approval of our parts department.
- Payment net 30 days (except parts covered by warranty).
- Freight collects (except parts covered by warranty).
- The warranty for repair parts is 30 days from date of shipment.

Parts replaced under warranty are on a “charge-credit” basis. We will invoice you when we ship the replacement part, then credit you when you return the worn or damaged part, and we verify that it is covered by our warranty. Labor is not covered under warranty for Parts orders.

7 TROUBLESHOOTING

PROBLEM	POSSIBLE CAUSE	CHECK
Lift will not raise but pump is running	Motor may be turning in wrong direction (3-phase only)	Swap any two phases of the motor power leads.
	Hose or hydraulic line is leaking	Correct as necessary. See Relieving Hydraulic Pressure section.
	Fluid level in reservoir is low	Add hydraulic fluid. See Hydraulic Fluid section.
	Load exceeds capacity requirements. Relief valve is bypassing the fluid back into the reservoir.	Do not change relief valve setting. Instead, reduce the load to rated capacity.
	Suction filter is clogged, starving pump	Remove filter, clean and reinstall.
	Suction line may be sucking air, due to loose fittings	Check fittings and tighten if necessary.
	Breather cap on reservoir may be clogged	Remove breather cap, clean and reinstall.
	Down valve may be energized or stuck open	Inspect solenoid wiring and repair if necessary. Remove solenoid valve, check, clean, and reinstall. See Hydraulic and Relieving Hydraulic Pressure sections.
	Hydraulic pump may be inoperative	Contact Customer Service.

PROBLEM	POSSIBLE CAUSE	CHECK
Lift rises too slowly	Foreign material stuck in down valve, causing some oil to bypass back into tank	Lower the lift and remove the down valve, clean and reinstall. See Hydraulic and Relieving Hydraulic Pressure sections.
	Foreign material clogging suction filter, breather cap, pressure line filter, or a pinched hose	Correct as necessary. See Relieving Hydraulic Pressure section.
	Low motor voltage	Ensure the machine is powered by a dedicated and appropriately fused circuit.
		3 phase supply voltage must be $\pm 10\%$ of the rated voltage at the motor terminals, single phase supply voltage must be $\pm 5\%$ of the rated voltage at the motor terminals.
		Measure voltage at motor terminals, or as near to the terminals as possible, while pump is running under load. If voltage is sufficient, check for inadequate or incorrect wiring as this can starve the motor. Correct as necessary.
	Lift overloaded	Do not change relief valve setting. Instead, reduce the load to rated capacity.
	Fluid is too thick for proper operation	May need to change to more appropriate fluid for the ambient temperature. See Relieving Hydraulic Pressure section.
	Lift operates with a shuddering vibration	Cylinder may be binding. Contact Customer Service.
Hydraulic Pump may be faulty	Contact Customer Service.	

PROBLEM	POSSIBLE CAUSE	CHECK
Lift lowers too slowly when loaded	Down valve clogged	Remove down valve, clean and reinstall. See Relieving Hydraulic Pressure section.
	Excess flow protectors may be triggering	Check for a damaged hose. See Relieving Hydraulic Pressure section.
		Down speed flow control valve may be opened too much. See Adjusting Down Speed Control Valve and Excess Flow Protectors sections.
	Down speed flow control valve may need to be opened more	Adjust valve 1/4 turn at a time to increase flow and test. See Adjusting Down Speed Control Valve and Excess Flow Protectors sections.
	Pinched tube or hose	Correct as necessary. In case of pipe, check for obstruction in line. See Relieving Hydraulic Pressure section.
	Fluid too thick for proper operation	May need to change to more appropriate fluid for the ambient temperature. See Hydraulic Fluid and Relieving Hydraulic Pressure sections.
	Foreign material stuck in down speed control valve	Lower the lift and remove the down speed control valve, clean and reinstall. See Hydraulic and Relieving Hydraulic Pressure sections.
Binding cylinders	Contact Customer Service.	
Lift lowers too quickly	Down speed flow control valve may need adjustment	Adjust valve 1/4 turn at a time to reduce flow and test. See Adjusting Down Speed Control Valve section.
Lift rises then lowers slowly	Down valve solenoid may have stray voltage or the valve is stuck open due to dirt	Inspect solenoid wiring, check leads for stray voltage and repair if necessary. Remove down valve, clean, and re-install. See Hydraulic and Relieving Hydraulic Pressure sections.
	External leak from lines or cylinders	Check for a damaged hose. See Hydraulic and Relieving Hydraulic Pressure sections.
		Cylinders may require repacking or replacement. See Hydraulic and Relieving Hydraulic Pressure sections.
Cylinder seals may be worn or damaged	Cylinders may require repacking or replacement. See Hydraulic and Relieving Hydraulic Pressure sections.	

PROBLEM	POSSIBLE CAUSE	CHECK
Lift has risen but does not lower	Incorrect down valve solenoid wiring or clogged down valve	Correct as necessary. See Electrical section.
	Down speed flow control valve fully closed	Adjust valve 1/4 turn at a time to increase flow and test. See Adjusting Down Speed Control Valve and Excess Flow Protectors sections.
	Down valve is stuck closed	Lightly tap down the solenoid coil body to seat it properly. Do not hit hard as it will permanently damage the internal stem. Do not remove the solenoid valve from the pump without first relieving the hydraulic pressure. See Relieving Hydraulic Pressure section.
	Faulty down valve solenoid coil	Remove and replace solenoid coil.
	Maintenance devices or some other object blocking down travel	Ensure that the reason maintenance devices or other object were blocking down travel no longer exists. Then raise lift and remove the maintenance device, or whatever other object that is blocking the down travel, then press the DOWN pushbutton. See Maintenance Devices section.
	Binding cylinders	Contact Customer Service.

8 ELECTRICAL

If your machine was supplied with a motor other than the one described here, contact the manufacturer for more information.

Control Voltage: 24/1/60

Motor: 1.5 HP

Primary Voltage	Phase	Frequency	Full Load Amp	Recommended Overcurrent Protection
460	3	60	2.4	3
230	3	60	4.8	6
208	3	60	5.3	10
230	1	60	8.5	10
208	1	60	9.4	15
115	1	60	17	20

Changing the primary voltage in the field will require changing some components and also other adjustments, **contact Presto Lifts Customer Service for further assistance.**

8.1 Wiring Schematics - Single-Phase and Three-Phase

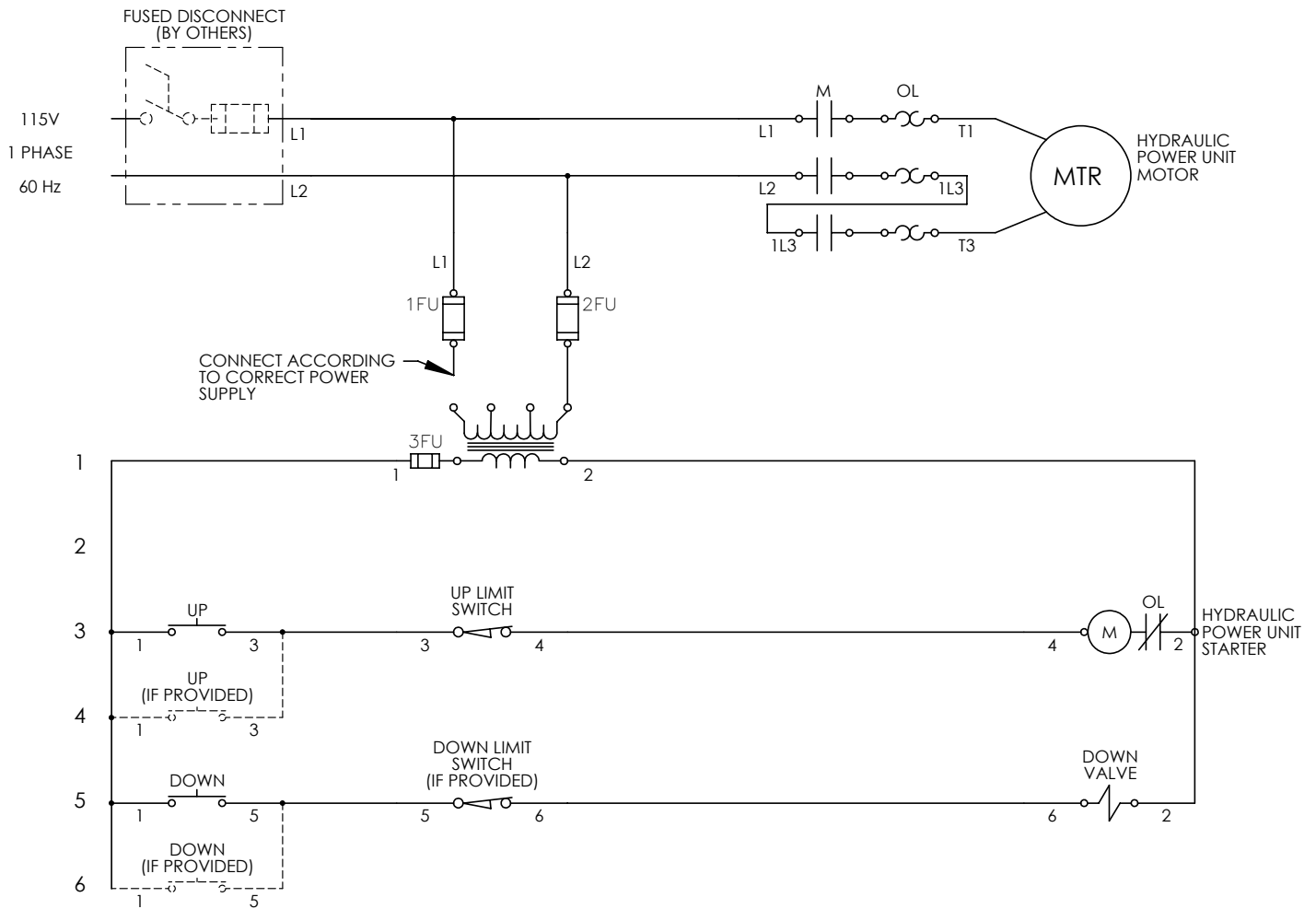

NOTES:

1. ALTHOUGH PUSHBUTTONS ARE SHOWN, FOOTSWITCHES MAY BE USED.
2. IF PROVIDED, TWO OR MORE OPERATOR CONTROLS MAY BE CONNECTED IN PARALLEL AS SHOWN.

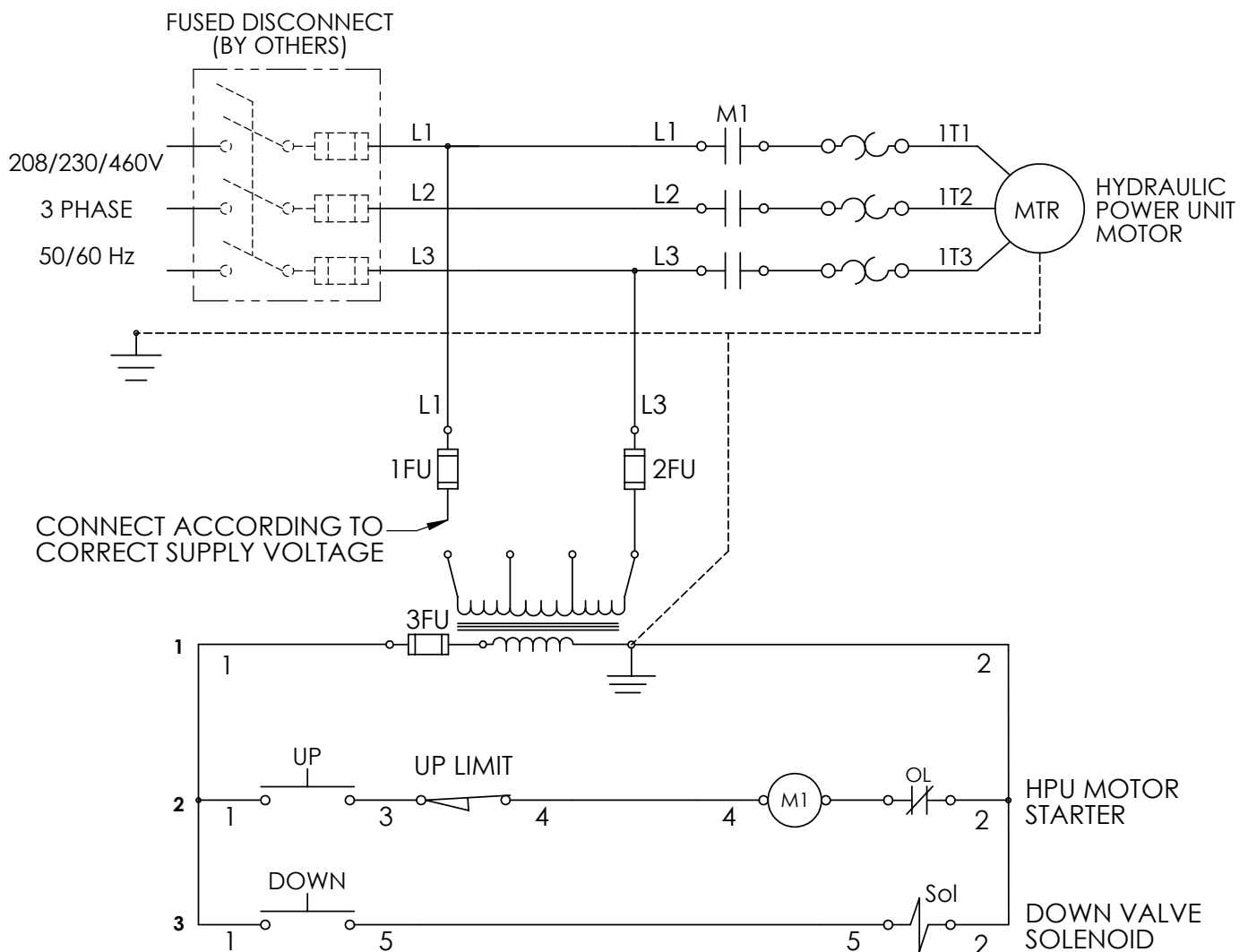
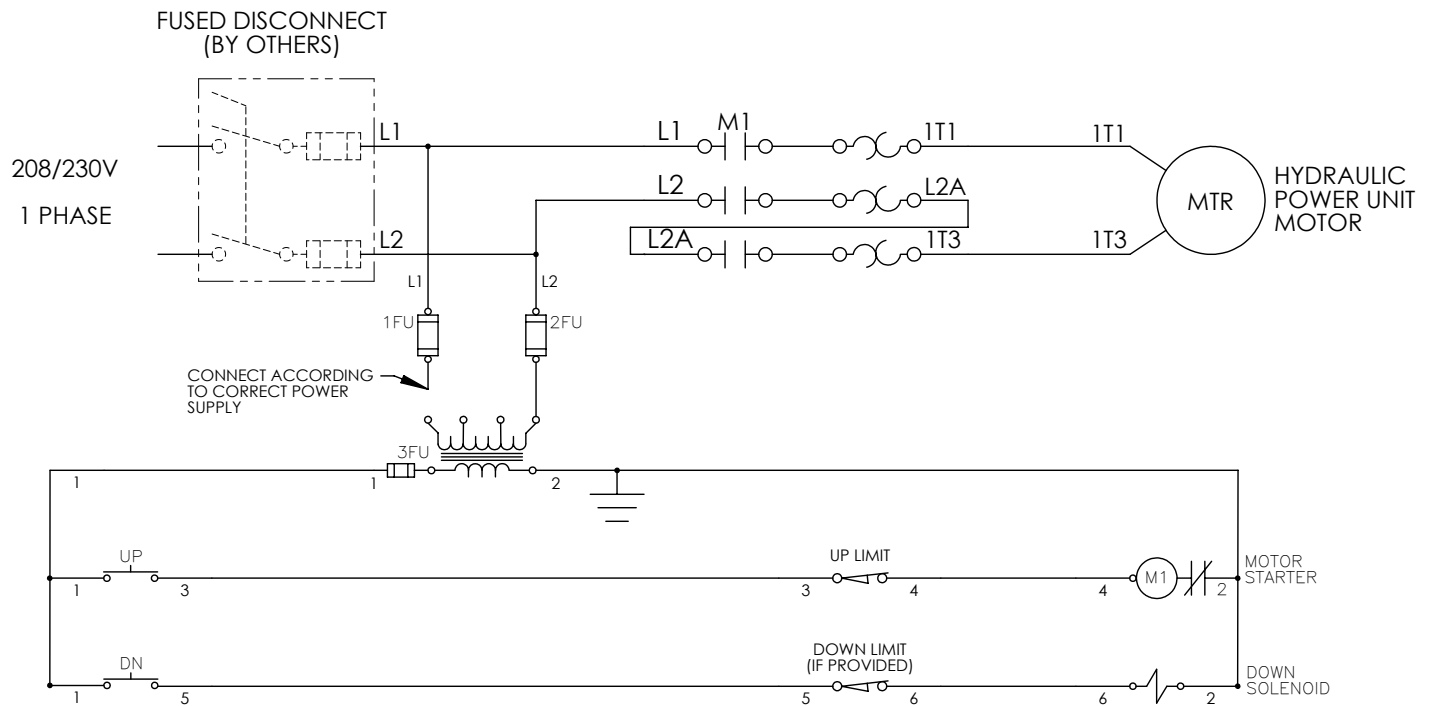

8.2 Typical Control Panel

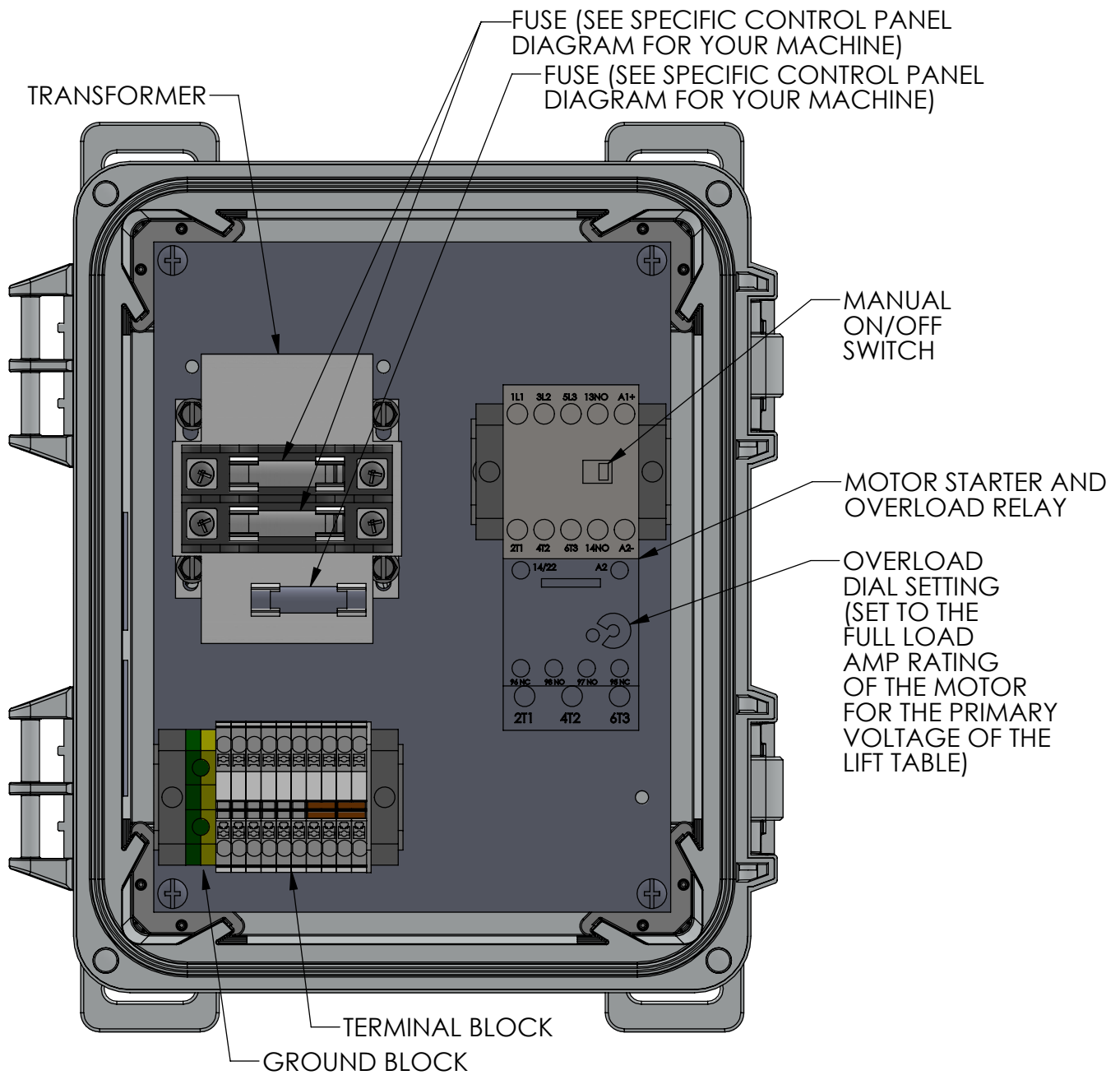

8.3 Handheld Pushbutton Control Pendant

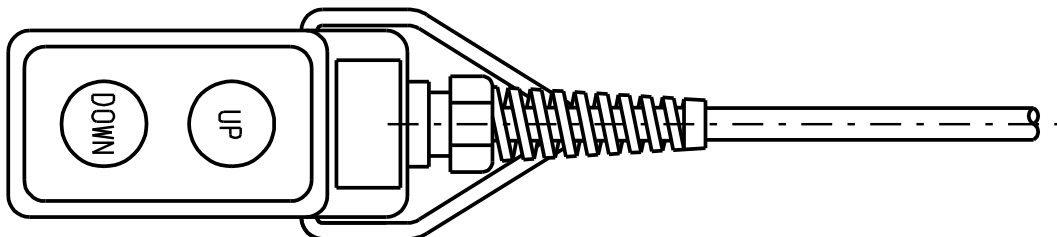

9 HYDRAULICS

9.1 Hydraulic Fluid

Presto Lifts supplies the unit with an AW32 hydraulic fluid or equivalent. This may be replaced by any other good quality oil with 150 SSU at 100° F and rust and oxidation inhibitors and anti-wear properties. If the lift will be used at ambient temperatures below 0°F, use a Type 15 aircraft hydraulic fluid.

NOTICE

It is particularly important to keep the hydraulic oil free of dirt, dust, metal chips, water, and other contamination. Most of the problems with hydraulic systems are caused by contamination in the hydraulic fluid.

9.2 Typical Hydraulic Schematic

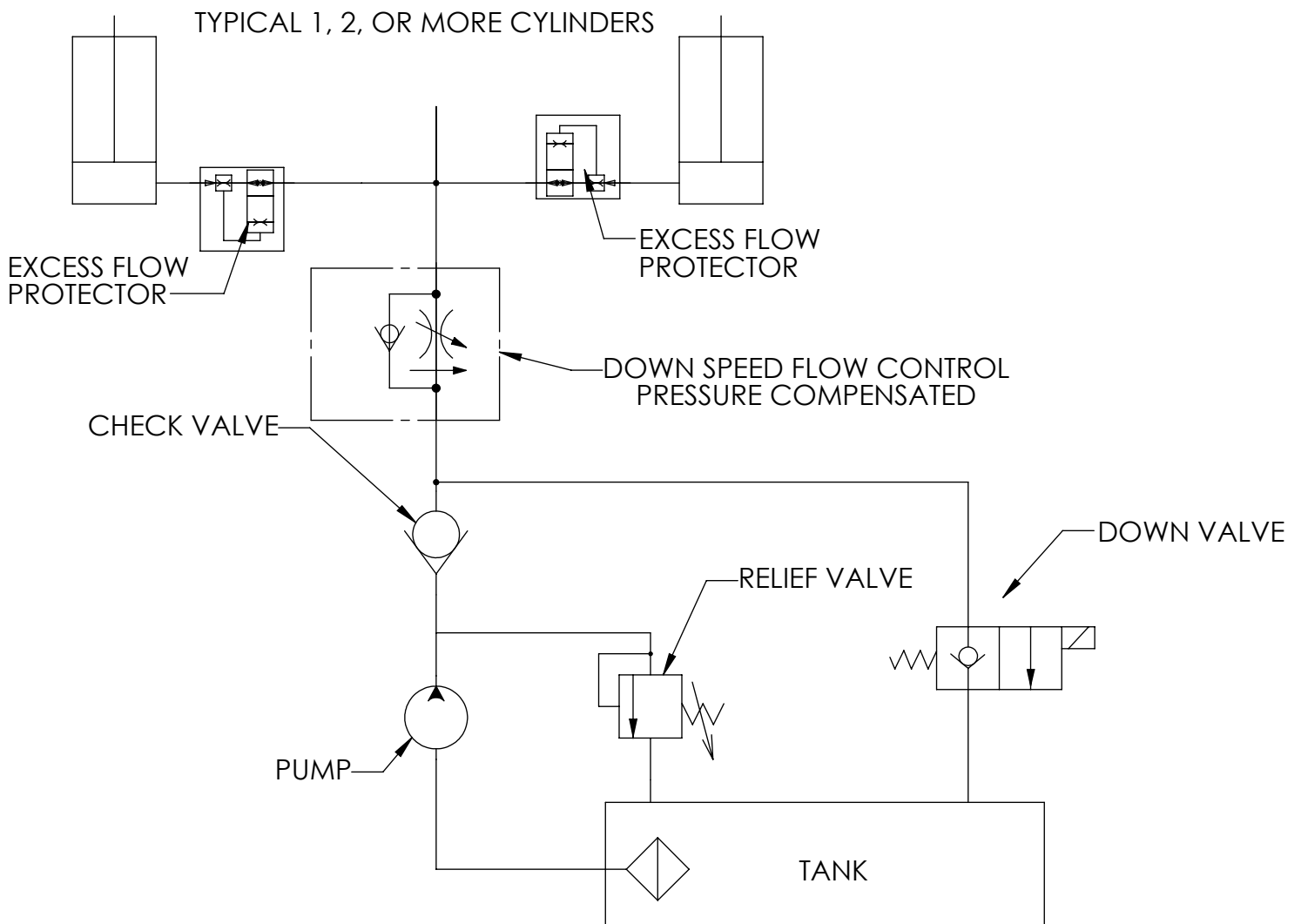

9.3 Typical Hydraulic Arrangement and Power Unit

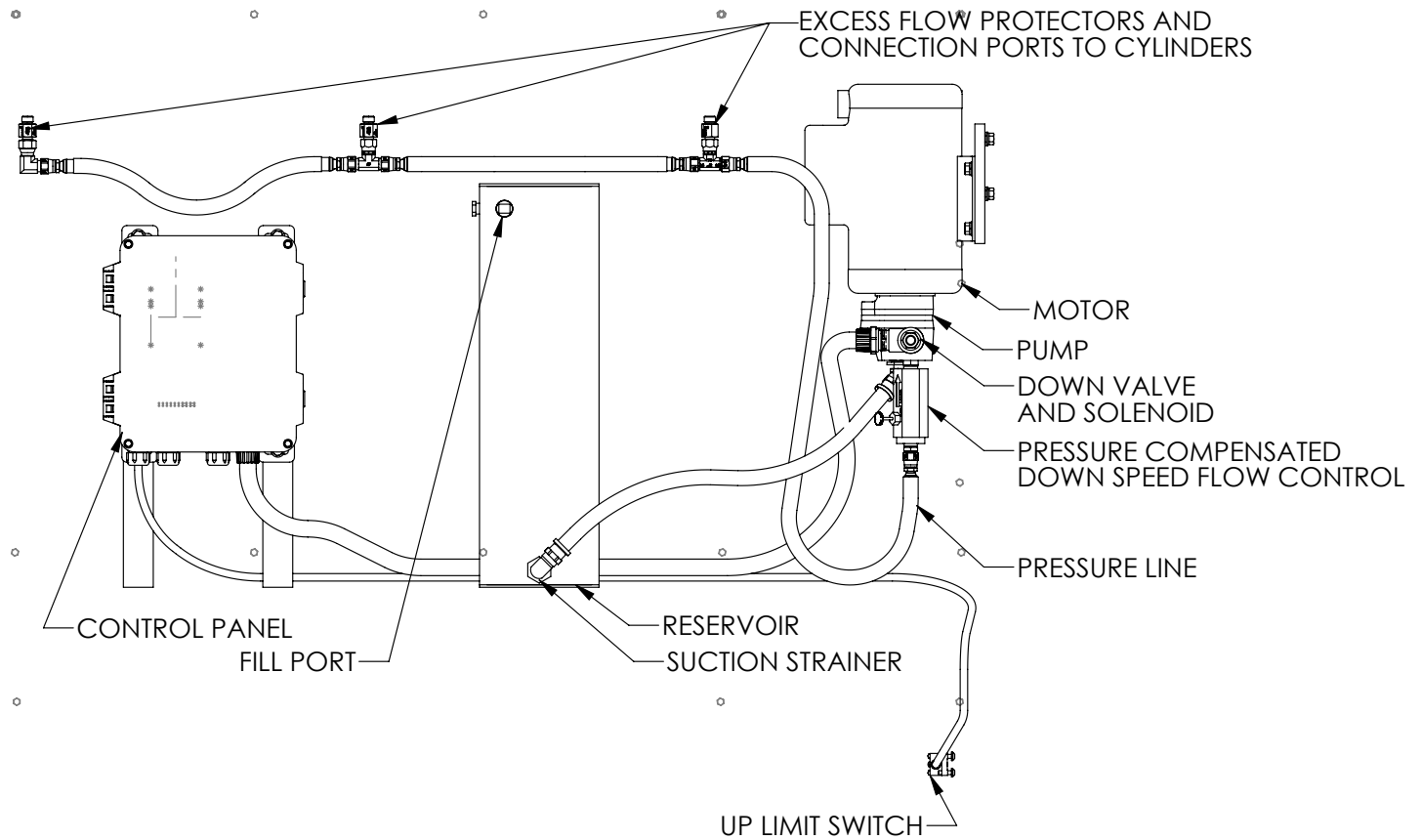

9.4 Excess Flow Protectors

This lift is equipped with an excess flow protector at the base of each cylinder. See **Hydraulic Arrangement and Power Unit, and Hydraulic Schematic** sections.

Typically, hydraulic lifts are actuated by single acting hydraulic cylinders. They are power up, gravity down. A hydraulic pump forces oil into the cylinder to raise the lift and a solenoid opens a valve allowing the oil to return to the reservoir thus lowering the lift. Any time a lift is raised, it is being supported by a column of oil.

If any part of the hydraulic piping system is compromised (hose or fitting leaks), the lift will descend.

An EFP (Excess Flow Protector) is a style of velocity protection device. They are sensitive to rapid velocity changes and they snap shut, but they allow oil to bleed past at a very slow rate after snapping shut, allowing the lift to descend very slowly.

EFPs are sensitive to any instantaneous change in oil velocity, such as surges caused from air bubbles in the oil. They are also sensitive to other things like viscosity and dirt. If oil thickens or dirt gets into the system, these devices could snap shut. Engineering selects an EFP to give the best combination of lift performance and protection, but sometimes these devices will shut off the lift when it is not wanted. This usually can be overcome by adjusting the flow control for a slightly slower down speed. Sometimes at installation air in the system must be worked out to stop the unwanted shut off of an EFP. As mentioned before, dirt can affect the operation of these devices and they may require removal and cleaning. See **Relieving Hydraulic Pressure** section.

10 WARRANTY & CONTACT INFORMATION

Presto Lifts warrants this product to be free from defects in material or workmanship for the duration of the warranty period. Warranty periods vary and begin on the date of shipment. For specific warranty information, contact Presto Lifts with the machine's serial number.

Any claim for breach of this warranty must be received in writing by Presto Lifts within the warranty period. Warranties shall not cover failure or defective operation, caused by misuse, misapplication, negligence or accident, exceeding recommended capacities, or any alteration or repair of the item purchased which has not been authorized by Presto Lifts. Except as set forth herein, Presto Lifts makes no other warranties, express or implied, including THE WARRANTIES OF MERCHANTABILITY AND OF FITNESS FOR A PARTICULAR PURPOSE, all of which ARE HEREBY EXCLUDED.

Presto Lifts meets the labeling requirements of California's Proposition 65. Presto Lifts makes no warranty or representation with respect to the compliance of any product with other State or local safety or product standard codes and any failure to comply with such codes shall not be considered a defect of material or workmanship under this warranty. Presto Lifts shall not be liable for any direct or consequential damages arising out of such non-compliance.

Presto Lifts' obligations under any warranty or for any other damages which may arise under any sale, agreement, or contract, are limited to the replacement or repair of defective components at its factory or another location at Presto Lifts' discretion. This is buyer's sole remedy under any such warranty, sale, agreement, or contract. Presto Lifts will not be liable for consequential, incidental, exemplary, or punitive damages of any kind resulting from a breach of any warranty that it has provided or for breach of any term of any sale, agreement, or contract. Any warranty may be altered only in writing by Presto Lifts.

All commodities, software, or technology purchased from Presto Lifts are subject to the export and re-export control laws and regulations of the United States, including but not limited to the Export Administration Regulations ("EAR") and Department of the Treasury Office of Foreign Asset Controls ("OFAC") Regulations. Presto Lifts expects all distributors and customers to comply with these laws and regulations. Without limiting the foregoing, the distributor/customer cannot, without proper authorization from the applicable United States Government Agency, export, re-export, or transfer any commodity, software, or technology purchased from Presto Lifts, either directly or indirectly, to any entity, country, or national of any country in breach of such laws and regulations. Furthermore, Presto Lifts expects that the distributor/customer shall indemnify and hold harmless Presto Lifts from and against any claim, proceeding, action, fine, loss, cost and damages arising out of or relating to any noncompliance with export control regulations by distributor/customer, and distributor/customer are expected to compensate Presto Lifts for all losses and expenses resulting thereof, unless such noncompliance was clearly not caused by fault of the distributor/customer.

Presto Lifts Inc., 50 Commerce Way, Norton, MA 02766
800.343.9322 | Fax: 888.788.6496
service@prestolifts.com
www.PrestoLifts.com



To view a copy of the Terms and Conditions of Sale, go to: <https://PrestoLifts.com>
(Find in About Us pull down menu)